



**ENERGETIKA**  
**ENERGETICS**

Published from 2004  
Ministry of Press and Information  
of Azerbaijan Republic,  
Registration number 3337, 07.03.2011

ISSN 1816-2126  
Number 02, 2022  
Section: English

# ECOENERGETICS

HONORARY EDITOR IN CHIEF: Fagan G. Aliyev

SENIOR EDITOR: Rashad G. Abaszade

## INTERNATIONAL REVIEW BOARD

Arif Pashayev, Azerbaijan  
Vagif Abbasov, Azerbaijan  
Vagif Farzaliev, Azerbaijan  
Khadiyya Khalilova, Azerbaijan  
Farhad Aliyev, Azerbaijan  
Sakin Cabarov, Azerbaijan  
Adil Azizov, Azerbaijan  
Azer Mammadov, Azerbaijan  
Nurmammad Mammadov, Azerbaijan  
Akif Alizadeh, Azerbaijan  
Rahim Alakbarov, Azerbaijan  
Gurban Eyyubov, Azerbaijan  
Yusif Aliyev, Azerbaijan  
Adil Abdullayev, Azerbaijan

Rafiq Aliyev, Azerbaijan  
Fuad Hajizadeh, Azerbaijan  
İsmayil Aliyev, Azerbaijan  
Nazim İmanov, Azerbaijan  
Ali Guliyev, Azerbaijan  
Leyla Mammadova, Azerbaijan  
Nazim Shamilov, Azerbaijan  
SalahaddinYusifov, Azerbaijan  
Mazahir İsayev, Azerbaijan

Turhan Vaziroglu, USA  
Shiro Takada, Japan  
Luca Di Palma, İtalia  
Yuriy Tabunshikov, Russian  
Mithat Kaya, Turkey  
Elvin Aliyev, UK  
Emre Gür, Turkey  
Volodymyr Kotsyubynsky, Ukraine  
Matlab Mirzayev, Russian  
Olga Kapush, Ukraine  
Aitbek Aimukhanov, Kazakhstan  
Aida Bakirova, Kyrgyzstan  
Baktiyar Soltabayev, Kazakhstan  
Dzmitry Yakimchuk, Belarusiya

## TECHNICAL EDITORIAL BOARD

SENIOR SECRETARY: İmran Y. Bayramov, Elmira A. Khanmamedova, Sevinj B. Nurmammadova, Rafael N. Gahramanov, Afiq M. Nabiyev, Turan A. Nahmatova, Nigar V. Abbasova, Rashid Y. Safarov, Nuranə A. Zohrabbayli, Seynura A. Hasanova, Kamila A. Cafarli.

### PUBLISHING OFFICE

5, M.Rahim, AZ-1073, Baku Azerbaijan

Tel.: 99412 538-23-70,

99412 538-40-25

Fax: 99412 538-51-22

E-mail: [info@ieeacademy.org](mailto:info@ieeacademy.org)

[ekoenergetics@gmail.com](mailto:ekoenergetics@gmail.com)

Internet: <http://ieeacademy.org>

[www.innovationresearch.az](http://www.innovationresearch.az)

# Contents

1. Environmental state of oil-contaminated lands of the Absheron peninsula on the territory of Govsan <i>F.G.Aliyev, Z.A.Nasirova</i>	4
2. Growth of graphene and applications of graphene oxide <i>R.G.Abaszade, R.Y.Safarov</i>	9
3. About slope slides expected in the upper level of reservoirs <i>Ch.B.Alizade</i>	16
4. Structured work of intelligent network technology <i>T.M.Isayeva, G.I.Asgerova</i>	19
5. Methodology of application of new information technologies in mathematics course in higher technical schools <i>I.Y.Bayramov</i>	23
6. Analysis of the ecological situation of Boyukshor lake <i>A.A.Khalilova, H.I.Ahmadzade</i>	29
7. About some technical safety and environmental problems of sarsang water reservoir <i>M.I.Maharramov</i>	34
8. Fuzzy identification of main characteristics of gas lift wells <i>A.Y. Aliyev</i>	37
9. History of hybrid cars <i>F.G.Aliyev, N.Q.Yusifli</i>	41
10. Shamakhy Astrophysical Observatory <i>Sh.M. Shafiyeva</i>	45
11. Obtaining and studying the properties of high-quality compost using biomass and wood ash <i>G.V. Shamilova</i>	48
12. Study of the composition of silicate concrete based on small fillings <i>S.M.Akbarova, V.U.Shahmarov, T.I.Mustafayev</i>	51
13. Development of mathematical models of complex oil refining technological processes <i>A.A.Safarova, H.M.Mammadli</i>	56
14. The dynamic and interactive nature of computational processes <i>A.N.Becanova</i>	61
15. Modern impulse ventilation for tunnels <i>T.M.Isayeva, S.Ch.Mammadov</i>	66
16. Development of electromechanic power control system <i>K.Murad, L.A.Aliyeva</i>	74

- |  |     |
|--|-----|
| 17. Modeling and simulation of working agent distribution between wells<br><i>S.I.Yusifov, S.A.Cabbarov</i>  | 81  |
| 18. Reduction of obstacles and noise in TV broadcasting systems<br><i>J.F.Sultanova, M.T.Narimanli</i>   | 85  |
| 19. Ecological situation of absheron peninsula and greening process in the<br>Baku urban areas<br><i>H.I.Suleymanov</i>  | 90  |
| 20. Adaptive diagnostic systems for cable communication lines<br><i>R.A.Mayilov, E.A.Khanmamedova, K.N.Hummatli</i>  | 94  |
| 21. Contribution to high performance computing and big data infrastructure<br>convergence<br><i>S.T.Mirzahmadova</i>   | 98  |
| 22. Electrical and optical properties of structures formed on the basis of thin<br>layers of different composition CdSe <sub>1-x</sub> S <sub>x</sub><br><i>E.A.Khanmamedova</i> | 101 |

## **Environmental state of oil-contaminated lands of the Absheron peninsula on the territory of Govsan**

**F.G.Aliyev, Z.A.Nasirova**

*Azerbaijan University of Architecture and Construction, Baku, Azerbaijan,  
[info@ieeacademy.org](mailto:info@ieeacademy.org), [nesirova-90@mail.ru](mailto:nesirova-90@mail.ru)*

**Abstract:** The presented article provides brief information about the general physical and geographical conditions, geological and geomorphological conditions, climate, and vegetation cover of the Absheron Peninsula. The consequences of the presence of heavy metals in the soil and ways of their disposal are analyzed.

**Keywords:** Absheron Peninsula, Govsan, Oil-contaminated lands, Heavy metals.

### **1.Introduction**

At the end of the second and third millennia AD, a paradigm shift took place in human thought and practice - economic priorities were replaced by environmental priorities. The same thing happens in soil science - the trend of agriculture in soil science, which has dominated the whole of the twentieth century, is increasingly being replaced by ecological. The agricultural (economic) direction requires the achievements of soil science, which lead to the growth of agricultural products, the ecological direction - the preservation of the soil's ability to perform its ecological functions, without which the sustainable existence of the biosphere and man is impossible. Mankind's future depends on whether it achieves a possible combination of economic and environmental interests in the near future. In this regard, soil scientists need to develop the most optimal combination of land use priorities.

Being an integral part of the biosphere as a whole, the soil performs a number of ecological functions, including the global biosphere, ensuring the sustainability of the biosphere and the very existence of life on earth. At present, the ecological functions of soil are divided into two major groups: ecosystem (biogeocenosis) soil functions and global (biosphere) land cover functions [7].

Almost all the problems that civilization faces in its interaction with lands are environmental problems. Mankind is accustomed to the idea that the earth cannot be harmed. Recently, however, experts, and then a growing part of society, have begun to realize that not only polluted air, poisoned water, and dead

vegetation, but also degraded soils pose a threat to humanity [11].

In the late 1980's, humanity apparently realized that by carelessly using the resources of the biosphere, it would soon pass the allowable load on the biosphere. This is evidenced by the growing number of studies in soil science on the problems of soil pollution, degradation and denudation as a result of anthropogenic impacts. All works are different in nature, but they are united by the desire of researchers to show the range of challenges facing humanity, born of the increasing pollution, the diversity of pollutants, the diversity of human impact on the soil. In this direction, solutions are being sought to mitigate the effects, resulting in a reduction in anthropogenic pressure on soils. Since soil cover is one of the components that determine the stability of the biosphere as a whole, this is one of the most important areas of modern natural science [7].

Govsan settlement is located in Surakhani district of Baku city, on the shores of the Caspian Sea, 40° 22' 31" and 50° 05' 02" şq.uz. located in the coordinates of the circle. The eastern part of the region borders on Khazar district, the northern part on Sabunchu district, and the western part on Nizami and Surakhani districts and has an area of 122 km<sup>2</sup>.

Relevant laboratory analyzes were carried out by taking soil samples from different depths, accepting oil-contaminated soils of different degrees as a key area in the area.

Both depth and field contamination of the samples were determined by washing them under laboratory conditions with hot water (90°C) and solvent (benzene).

## **2. Experimental details**

The Absheron Peninsula is located on the left bank of the Caspian Sea and forms the southeastern end of the Greater Caucasus Range. The eastern part of the Absheron Peninsula is significantly washed into the Caspian Sea by its waters from the north, east and south. It extends in the latitudinal direction, gradually narrows to the east, and finally turns south from the meridional direction, ending in the Shikh arc.

The Absheron Peninsula rises gradually to the west, forming a weakly fragmented smooth, weakly wavy plain, which is primarily due to the young relief. Arid climatic conditions have led to the formation of arid-denudation, saline-deflationary and steppe relief forms in the Absheron Peninsula.

The slopes, hills and plateaus of the highlands are stepped, which is due to the sea terraces of the time [4,13].

Soil-forming rocks in the Absheron Peninsula are composed of the third and fourth periods of the Kaynazoy and the ancient sediments of the Caspian Sea. In the process of soil formation, mainly dark clay shales of the Lower Jurassic, gray-brown clay or sandy-gravel of the Middle Jurassic, as well as marl, gray and red-green clays are observed. Tertiary sediments and anthropogenic sediments are widespread in the area. Sediments from earlier periods (chalk) are found only on the north-western part of the peninsula. Alluvial-proluvial sediments are distributed along several river terraces in the Sumgayit river valley and some dry valleys in the western part of the peninsula and consist mainly of yellowish-gray dusty clays and sands with a mixture of river stone, gravel [10].

The climate of the Absheron Peninsula is arid desert, hot and dry summers, and mild subtropical winters. Evaporation exceeds precipitation from the soil surface 100-250mm. The number of sunny days reaches an average of 300. The only water source is the Samur Absheron canal. Due to these features, the Absheron Peninsula belongs to the hot semi-desert and dry semi-desert climate type [14].

The annual amount of total radiation in Absheron in the north of the peninsula (Sumgayit) is 130.0kcal/sm<sup>2</sup>, and varies from 4.2 to 18.7kcal/sm<sup>2</sup> per year. The amount of radiation balance is 51.3kcal/sm<sup>2</sup> per year, 0-9.0kcal/sm<sup>2</sup> per month. In the central part of the peninsula (Mashtaga) it fluctuates between 130kcal/sm<sup>2</sup> and

3.8-19.0kcal/sm<sup>2</sup>, 50.5kcal/sm<sup>2</sup> and 0.1-8.9kcal/sm<sup>2</sup>, and in the south-Baku 133.0 kcal/sm<sup>2</sup> and 4.1-18.8kcal/sm<sup>2</sup>, 50.50 kcal/sm<sup>2</sup> and 0.1-8.5 kcal/sm<sup>2</sup> [10].

The number of sunny days in the Absheron Peninsula is high, and the temperature is high due to the relatively high angle of the sun's rays. The average annual temperature is 13.6°C in the north, 13.5°C in the center and 41.4°C in the south. In the south, the average annual temperature is 0.8-0.9°C higher than in other areas. The average monthly temperature is positive in all months, ranging from 3.0 - 25.7°C for individual months.

In April-November (spring, summer and autumn), the average monthly temperature varies between 10.0-25.7°C. Due to the active temperature of these months, it is possible to grow various agricultural crops (vegetables, cereals and legumes) during this period. Due to the positive temperature throughout the year, drought-resistant dry subtropical trees (olive, pomegranate, pistachio, almond, etc.) can also be grown. Absolute maximum air temperature (average annual) 40 - 42°C, average relative humidity 70-76%, possible evaporation 992-1140mm, average wind speed 5.8-7.0m / sec, windy (> 15m/sec) The number of days is 64-139 days, the number of white windy days is 14-14.9 days [14].

It has been determined that mainly north and north-west winds play a role in the climate of the peninsula as a climatic factor [14].

According to the latest data of the State Land and Cartography Committee of the Republic in 2012, the territory of Absheron region with a total area of 227406.0ha is 9961.0ha of arable land, 3131.0ha of perennial crops, 5498.0 ha of arable land, 96898.0ha of pastures 115488.0ha of agricultural land. The total area of irrigated lands in the area is 15600.0ha, including 7172ha of arable land, 3131.0ha of perennial plantings (292.0ha of vineyards), 2839.0ha of other perennial plantations, 758.0ha of fallow land, 2112, 0 ha falls to the share of agricultural lands. In addition, there are 246 hectares of irrigated collective gardens and 151.20 hectares of forests in the area [1].

Researchers of the gray-brown soils prevailing in Absheron have identified the following subtypes of gray-brown soils in Absheron: saline gray-brown; saline and saline gray-brown; saline irrigated gray-brown; saline irrigated gray-brown; deep gypsum gray-brown; immature gray-brown; primary sandy-

sandy gray-brown; swampy gray-brown; sandy soils and various rock complexes; different types of salts; technogenically disturbed and oil-contaminated soils [3].

From the surface of the soil to the depth, the degree of pollution increases to a certain depth and then decreases. Laboratory studies of in-depth samples confirm these assumptions. The degree of contamination of the wellhead (0.5-1.0m) and samples taken every 5 m increases to a depth of 20-60m, depending on the distance from the well, and gradually decreases.

While the depth of contamination in the wellhead area is 0.8m and more, it varies between 0.1 - 0.15m at a distance of 30 - 40m. Weakly and moderately polluted lands cover 20-25m away from production wells in all mining areas and between decommissioned, oil-contaminated and swampy areas. At the same time, surface pollution includes areas contaminated as a result of accidents on oil collection lines, areas contaminated with oil leaks from pipe joints and valves.

Highly contaminated land areas include areas around wells (up to 15 - 20m), old artificial reservoirs where oil and water have accumulated, and depressions. In these oil deposits, "dead" areas have been created that cannot be cleaned up as a result of wind, dust, sand and plant debris being dumped and over time the oil condenses into "tar" under the influence of the sun. Many oil fields are polluted by anthropogenic and man-made processes. Waste from industrial enterprises built in connection with the extraction and refining of oil, household waste from cities and settlements, and construction materials are uncontrolledly dumped into mining sites and pollute the soil. Sand and stones are extracted from the mines as construction materials, and large pits appear in their places. Later, these pits are filled with rain, snow and mineral water, and puddles are formed.

In addition, water used for oil and technical purposes is collected in depressions in the mining area, occupies large areas and in some places turns into a swamp, covered with vegetation. Soil, which is formed under the influence of natural factors over a long geological period and is a means of production, is subject to change, degradation and destruction if not used effectively as a result of direct and indirect human intervention.

Contamination of soil with heavy metals occurs as a result of air, irrigation water, oil production, exhaust

gases, organic (cadmium-rich), phosphorus (contaminated with uranium and lead) fertilizers, pesticides (preparations with mercury). As an object that collects soil and provides the biological chain with heavy metals, the interest in studying its composition is growing every year. It should be taken into account that 350kg/ha of harmful substances enter the soil every year due to emissions into the atmosphere. Sufficient work has been done by both foreign and Azerbaijani scientists to study the presence of heavy metals in the soil [1,12].

F.V.Sultanzadeh [9] studied the diagnostic features of the gray-brown soils of the Absheron Peninsula, compiled soil and ecological assessment maps on a scale of 1: 100000 on the basis of soil plasticity, and identified radioactive elements along with microelements and heavy metals in oil-contaminated soils. Using scales for micronutrient deficiencies or excesses, the author established a correlation diagram of the distribution of regions by establishing a correlation of cardiovascular, neurological, skin and venereal diseases according to the population of the administrative districts of the Absheron Peninsula. He noted that the prevalence of oncological diseases is highest in the oil-contaminated areas, where radium, thorium and potassium are 2.5 - 3 times higher than the permissible limits - in Balakhani, Surakhani, Ramani, Lokbatan and Binagadi districts.

Ch.T. Bakhshiyeva [5] notes that microelements B, Mo, Cu, J, Mn predominate in the oil-contaminated soils of the Absheron Peninsula.

The acquisition application of new smart materials by R.G.Abaszade and others has been extensively investigated [15-20].

H.Aslanov and S.Safarli [1] state that microelements and heavy metals (with an atomic weight of more than 40) are the main pollutants in the environment. Heavy metals are active pollutants due to the activity of metals. The physiological effects of heavy metals on human and animal organisms are different, depending on the properties of the metal, the type and amount of the compound present in the natural environment. Among the available heavy metals are heavy metals called biogenesis, which are extremely important for the life of humans and other living organisms. Others, when ingested, lead to its poisoning or destruction and are considered xenobiotic, ie elements that are alien to all living things. N.F.Hakimova [2], taking into account the

physical, physicochemical properties of oil-contaminated soils of Absheron, the composition of microelements and the amount of radioactive elements, the biological activity of oil-contaminated gray-brown soils, the composition of oil, their impact on food dynamics and sanitary-hygienic indicators. The soils are ecologically assessed. For the first time, Y.N.Kuliyeva [6] conducted a comprehensive study of the ecological condition of soils (2445ha) and identified unfavorable environmental factors of man-made degraded gray-brown soils near industrial facilities in Sumgayit and Garadagh districts of the Absheron Peninsula. The author assessed exogenously disturbed lands and developed a system for assessing lands contaminated with heavy metals. Depending on the degree of pollution, surface structures, railways and highways, etc. Correction coefficients have been developed, ecological grouping of soils has been carried out, average ecological scores of lands of research objects have been determined, ecological assessment of contaminated areas has been carried out and map-scheme of ecological assessment of man-made disturbed lands of Sumgayit massif and Garadagh region at 1: 100000 scale has been compiled. The literature states that the complete extraction of oil components from the soil shows that for different soils, the initial contamination rate is 4-15% and the duration of the interaction of pollutants with the soil is up to 5 months, the extraction rate increases from 61% to 66%. Long-term pollution creates certain difficulties in the

removal of oil from the soil. This is due to the fact that under the influence of natural factors (oxidation, photo oxidation, microbiological oxidation, compounds with soil humus, etc.) some petroleum substances combine with organic solvents to form non-extractable forms [1].

In the Zikh-Govsan massif, weak, medium and highly polluted soils were accepted as key areas at the research object, and heavy metals were identified in soil samples.

As can be seen from the table, the concentration of heavy metals increases in the 0-10, 10-20 and 20-30 cm layers as the depth increases in both lightly contaminated and moderately and heavily contaminated soils. Thus, in lightly contaminated soils, Al is 5864, Ni- 0.164, Zn- 16.9mg/kg in the upper layer, while in the lower layers the corresponding plate is 8044, 0.181 and 35.7(mg/kg) below the allowable limit. (YVH-Ni-40, Zn-50(mg/kg)), in moderately polluted soils, Ni and Zn are twice as high as in YVH, especially in highly polluted soils, and are 56.1 and 71.2(mg/kg).

In general, the highest concentration is Al and Fe, followed by B. The values of these elements fluctuate sharply depending on the degree of contamination in the soils and are 43491, 27300 and 686.4, respectively, and 3 times higher than in poorly compacted soils.

The same direction manifests itself in Pb and V. The values of these heavy metals are 6.28 and 20.2(mg/kg) in lightly contaminated soils, and 20.4 and 83.6(mg/kg) in heavily contaminated soils.

**Table 1**

Concentration of heavy metals in oil-contaminated soils (mg / kg) 2022													
Deep, cm	Pollution level	Al	As	Ba	Cd	Cr	Cu	Fe	Ni	Pb	Sr	V	Zn
0-10	poorly polluted	5864	12.94	398.4	0.149	17.92	10.21	6921	0.164	6.28	774	20.2	16.9
10-20		6889	4.63	321.6	0.135	14.42	12.79	6432	0.181	12.32	893	20.3	35.7
20-30		8044	11.72	275.2	0.148	15.44	10.61	6917	<0.06	6.23	803	18.9	23.7
0-10	Moderately polluted	22607	13.53	270.4	0.219	43.4	25.4	14697	<0.06	14.3	698	54.6	51.5
10-20		25506	8.78	422.4	0.107	35.2	19.12	14725	0.102	12.5	282	46.1	48.1
20-30		28078	14.12	316.3	0.111	54.1	23.4	18983	0.072	14.23	486	69.7	56.1
0-10	Very polluted	31795	18.37	686.4	0.082	53.1	29.9	23398	0.071	15.4	342	63.2	59.5
10-20		32351	5.32	221.8	0.078	51.9	26.2	17957	0.658	18.15	1510	76.2	56.7
20-30		43491	9.97	180.1	0.113	59.8	33.8	27300	0.094	20.4	355	83.6	71.2

Chromium and copper levels were 59.8 and 33.8(mg/kg), respectively, 2.5-3 times higher than

clarkes and poorly contaminated soils in highly contaminated soils. The CD price is low and



fluctuates around 0.078-0.219(mg/kg).

### 3. Conclusions

The farther away from the well, the less pollution there is. While the pollution level at the wellhead is 8-10% (volume), it is 1.0-1.5% at a distance of 30-40m. It was found that depending on the degree of oil pollution, the concentration of heavy metals also

increases.

Due to the fact that the surface of the soil is covered with fine sand particles that have risen to the surface with produced water, pollution with oil products is in the layers of 30 sm and below.

### References

- 1.H.G.Aslanov, S.A.Safarli, Oil-contaminated lands of Azerbaijan, their reclamation and development, Baku, p.191, 2008.
- 2.N.F.Hakimova, Fertility model of oil-contaminated soils in Absheron peninsula, Baku: Works of the Institute of Soil Science and Agrochemistry of ANAS, pp.408-415, 2004.
- 3.V.H.Gasanov, Ch.S.Galandarov, R.Sh.Aslanova, I.M.Babayev, Influence of relief and soil-forming rocks on the structure of the soil cover of the Absheron Peninsula, Collection of soil science and agrochemical works, pp.156-179, 2004.
- 4.M.A.Museyibov, Physical geography of Azerbaijan – Baku, 232 p., 1998.  
<https://gsaz.az/ci/Kitabxana/museyibov%20azerbaycanin%20fiziki%20cografiyasi.pdf>
- 5.Ch.T.Bakhshieva, N.F.Akimova, Some problems of nature use of the Absheron Peninsula, Renaissance Materials of scientific-practical conference, Baku, pp.113-114, 2000.
- 6.E.N.Kulieva, Ecological assessment of technogenically-disturbed lands of Absheron, author's ref. Kandi diss./Baku, 16 p., 2006.
- 7.M.A.Glazovskaya, Methodological bases of ecology - geochemical stability of soil to man-made effects, Moscow. : Izd-vo Mosk. Un-ta, 102 p., 1997.
- 8.V.P.Smirnov-Loginov, Soils of the Absheron Peninsula, Baku: 1927.  
<https://biomedres.us/fulltexts/BJSTR.MS.ID.000382.php>
- 9.F.V.Sultanzade, Ecological assessment of the soil cover in the conditions of the Absheron Peninsula, Author's abstract. Diss...Candidate of Biological Sciences, Baku, 21p., 1997.
- 10.K.M.Sultanov, Absheron tier Baku, 304 p., 1964.
- 11.B.K.Shakuri, O.G.Mamedov, Contents of heavy metals contaminants in the soil of the Absheron Peninsula, Proceedings of the International Congress on Ecology, Baku, pp.3-7, 2000.
- 12.B.G.Shakuri, O.G.Mamedov, Technogenic pollution of the environment of the Absheron Peninsula. Baku, pp.7-72, 2001.
- 13.N.Sh.Shirinov, Eolian landforms of the Absheron Peninsula, Iz.AN Azerb. SSR. P.187, 1965.
- 14.E.M.Shikhlin'sky, Thermal balance of the Azerbaijan SSR. Baku, 199 p., 1969.
- 15.R.G. Abaszade, Analysis of carbon nanotubes, AJP Fizika, Vol.26, №2, section: Az, pp.25-29, 2020.  
[http://www.physics.gov.az/physart/256\\_2020\\_02\\_25\\_az.pdf](http://www.physics.gov.az/physart/256_2020_02_25_az.pdf)
- 16.S.R.Figarova, E.M.Aliyev, R.G.Abaszade, R.I.Alekberov, V.R.Figarov, Negative Differential Resistance of Graphene Oxide/Sulphur Compound, Journal of Nano Research Submitted, Vol.67, pp.25-31, 2021.  
<http://dx.doi.org/10.4028/www.scientific.net/JNanoR.67.25>
- 17.R.G.Abaszade, O.A.Kapush, S.A.Mamedova, A.M.Nabiyev, S.Z.Melikova, S.I.Budzulyak, Gadolinium doping influence on the properties of carbon nanotubes, Physics and Chemistry of Solid State, Vol. 21, №3, pp. 404-408, 2020.  
<https://doi.org/10.15330/pcss.21.3.404-408>
- 18.R.G.Abaszade, O.A.Kapush, A.M.Nabiyev, Properties of carbon nanotubes doped with gadolinium, Journal of Optoelectronic and Biomedical Materials, Vol.12, №3, pp.61–65, 2020.  
[https://www.chalcogen.ro/61\\_AbaszadeRG.pdf](https://www.chalcogen.ro/61_AbaszadeRG.pdf)
- 19.R.A.Namazov, R.G.Abaszade, Properties of graphene based solar panels (review), Ecoenergetics, №1, pp.3-8, 2022.  
<http://ieeacademy.org/wp-content/uploads/2022/05/ECOENERGETICS-JOURNAL-No1.-2022.pdf>
- 20.Kh.M.Popal, R.G.Abaszade, Research and modeling of hybrid energy systems (review), Ecoenergetics, №1, pp.65-69, 2022.  
<http://ieeacademy.org/wp-content/uploads/2022/05/ECOENERGETICS-JOURNAL-No1.-2022.pdf#page=66>

## **Growth of graphene and applications of graphene oxide**

**R.G.Abaszade, R.Y.Safarov**

*Azerbaijan State Oil and Industry University, Baku, Azerbaijan,  
[abaszada@gmail.com](mailto:abaszada@gmail.com), [rashidyunosoglu98@gmail.com](mailto:rashidyunosoglu98@gmail.com)*

**Abstract:** Graphene is a steeply ascending material in the field of materials science and solid state physics. This hardly two-dimensional material exhibits exceptionally high crystal and electronic quality and, despite its short past, has already provides plentifulness of new physics and potential applications, which are shortly talked around here. Obviously, the reality of applications can be acceptable if they carry on commercial purpose and effectiveness, however, according to researches on graphene`s physical properties it has been proved importance of itself. Its unusual electronic spectrum, graphene has caused to the emergence of a new perspectives of “relativistic” condensed matter physics; where unobservable quantum relativistic phenomenas can be imitated and tested in the table-top experiments. In general, graphene represents a conceptually new class of materials that are only one atom thick and offers new influxes into low-dimensional physics that continues to provide a fertile ground for applications. Graphene oxide is a unique material can be considered as a single monomolecular layer of graphite with different oxygen containing functionalities such as epoxide, carbonyl, carboxyl and hydroxyl groups. Interest in graphene oxide has been increased dramatically after graphene, a single layer of graphite, was first isolated and studied. A fabrication way of graphene oxide is extremely like pristine graphene that is a notable call in the field. Thanks to its moderate conductivity, graphene oxide is an attractive material for electronic devices. In addition graphene oxide has been used in nanocomposite materials, energy storage, biomedical applications and as surfactants.

**Keywords:** Graphene, Two-dimensional material, Graphene oxide, Nanocomposite material, Energy storage, Biomedical applications.

### **1.Introduction**

Graphene is the name of a flat monolayer of carbon atoms closely packed into a two-dimensional (2D) honeycomb lattice, and is a basic building block for graphitic materials of all other dimensionalities (Figure 1). It can be folded up into 0D buckyballs, rolled into 1D nanotubes or piled into 3D graphite. Graphene (or “2D graphite”) has been studied for sixty years and widely used for describing properties of various carbon-based materials. By the time, it was realized that graphene also provides a perfect dimensional quantum electrodynamics, which pushed graphene an ascending theoretical model. Graphene also is believed that it plays important role in the formation of soot, fullerene and carbon nanotubes.

Until 2004, 2D materials were assumed that do not exist, afterwards, by the experimental discovery of graphene and other free-standing 2D atomic crystals (for example, single-layer boron nitride and half-layer BSCCO) scientific sphere was astonished. These crystals could be obtained on top of non-crystalline substrates, in liquid suspension, and as suspended

membranes. Another benefit of 2D graphene is charge carriers can travel thousands interatomic distances without scattering. 2D crystallites can be reassured in a metastable state because of their small size ( $\ll 1\text{mm}$ ) and strong interatomic bonds, additionally, thermal fluctuations cannot lead to the generation of dislocations or other crystal defects even at high temperature [1-3]. The present article is devoted to the analysis of carbon nanotubes and carbon nanotubes doped by gadolinium. The carbon nanotubes obtained by the electric arc method and the carbon nanotubes doped by ten percent gadolinium have the form of rectangular parallelepiped. Then they are studied by X-ray phase analysis and Raman scattering methods. The significant changes in X-ray phase and Raman scattering analyzes are carried out at changes of mechanical properties of carbon nanotube. This can be explained by the weakening of  $sp^2$  hybridization [4]. In the work [5] for the combination of graphene oxide/sulfur (GO/sulfur) on the volt-ampere characteristic (VAC) are found

sections with negative differential conductivity (NDC). This has led to even greater interest in such structures, as from the point of view of the study of mechanisms of similar effects, as well as from the position of the implementation of new functional possibilities of these structures in electronics. For the identification of physical mechanisms and purposeful implementation of the properties of the structure on the basis of the GO/sulfur combination is the sufficiently effective approach to the modeling of sites VAC, as well as all the characteristics in general. Of particular interest in this is the plot with NDC.

Various physical properties of graphene-based samples were analyzed. The study of the graphene-based samples was performed using scanned electron microscopy (SEM), energy dispersion analysis (EDA), X-ray diffraction analysis, Raman scattering and IR luminescence, and noted the strong effect of the additive on the physical properties [6]. The results of an analysis of some properties of carbon nanotubes using X-ray diffraction analysis, Raman scattering, and IR luminescence is given. After doping with gadolinium the peak intensities in X-ray and Raman spectra drastically increase. It was found that 15% doping with gadolinium strongly affects the physical properties of carbon nanotubes functionalized by a carboxyl group [7].

Solar panels are a promising and potentially important technology and the future of sustainable energy for human civilization. At the same time, information was provided about graphene-based solar panels. The presented article is devoted to the summary of solar panels. The article examines the characteristics of different types of solar panels. In addition, the characteristics of graphene-based solar panels differ from others [8].

Half breed renewable vitality frameworks (HRES) are getting to be prevalent for inaccessible region control era applications due to propels in renewable vitality innovations and consequent rise in costs of petroleum items. Financial angles of these innovations are sufficiently promising to incorporate them in creating control era capacity for creating nations. Investigate and improvement endeavors in sun powered, wind, and other renewable vitality advances are required to proceed for, progressing their execution, building up procedures for precisely foreseeing their yield and dependably joining them with other ordinary creating sources. The paper portrays strategies to demonstrate HRES components, HRES plans and their assessment. The patterns in HRES plan appear that the crossover PV/wind vitality frameworks are getting to be picking up prevalent [9].

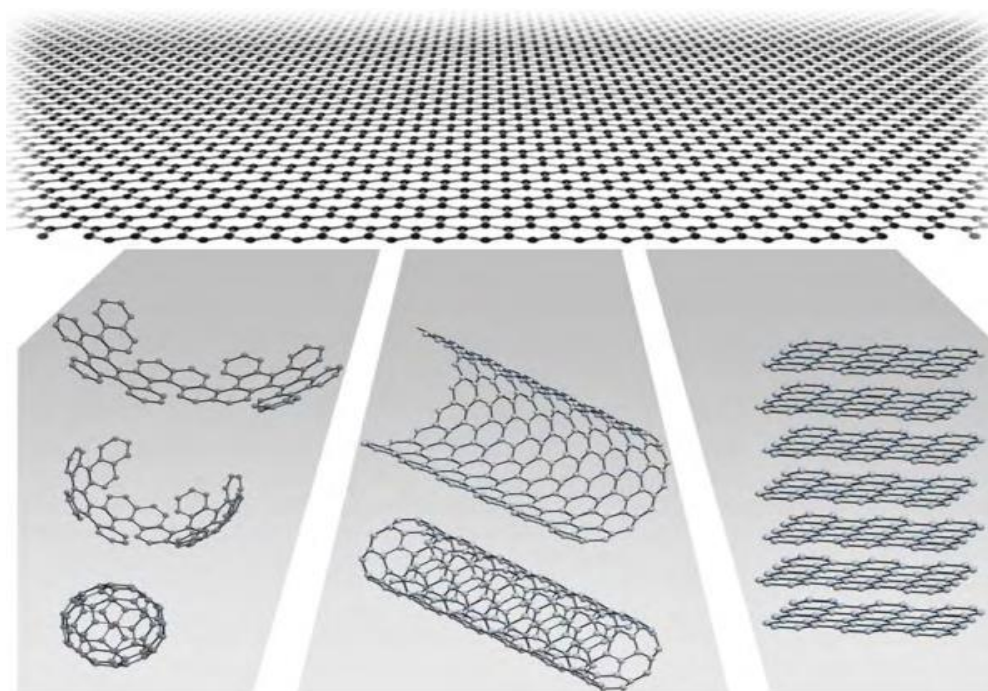

*Figure. 1. All graphitic forms. Graphene is a 2D building material for carbon materials of all other dimensionalities. It can be wrapped up into 0D buck balls, rolled into 1D nanotubes or stacked into 3D graphite.*

As known, a single atomic plane is 2D, and approximately, 100 layers can form a thin film of 3D material. Then, how many layers are needed to obtain a 3D structure? Owing to graphene studies, this curiosity has been satisfied. It has been identified that the electronic structure grows as the number of layers increase. 3D limit of graphite has been detected as 10 layers. Graphene and its bilayer have simple electronic spectra - they are both zero-gap semiconductors with one type of electrons and one type of holes. For 3 and more number of layers, the electronic spectra becomes more and more complicated: Different charge carriers emerge, and conduction and valence bands begins especially overlapped. This enables to realize distinguishment between single-, double- and few- (3 to 10) layer graphene as three types of 2D graphenes. 10 and more layer structures should be accepted as thin films of graphite, not graphene.

In the early times, to purify the graphene from graphite endeavors focused on chemical exfoliation method. In order to gain separate graphene layers by intervention of atoms or molecules, mass graphite was piled in the first stage of process. As a result, it usually finished in new 3D materials. In definite situation, large molecules inserted between atomic planes, so it provided wider pores and this resulting compounds were considered as purified graphene layers. Besides chemical exfoliation method, obtaining a sludge by chemical reactions handed assembled and scrolled graphene sheets. Since unmanaged character of graphitic sludge, this way caught very little curiosity.

A few attempts have been done to grow graphene. By getting rid of intercalating molecules in a chemical reaction method mainly used to grow carbon nanotubes. On the other hand, single- and few-layer graphene have been enlarged epitaxial way of chemical vapour deposition of hydrocarbons on metal

substrates and by thermal decomposition of SiC. Later, few-layer graphene that obtained on SiC was featured its electronic properties, discovering high-mobility charge carriers. Epitaxial growth of graphene provides probably the only productive and sustainable path towards electronic applications, and swift improvement is hoped in this field [3-15].

At present, empirical groups are dealing with samples which obtained by micromechanical cleavage of bulk graphite. This technique permitted the isolation or purifying of graphene for the first time. After better-tuning, the technique now gives opportunities of high-quality graphene crystallites up to 100  $\mu\text{m}$  in size, which is enough for most for experimental research aims (Figure 2). The technique is carried out drawing by a piece of graphite and followed by repeated peeling with sticky tape up to thinnest piles are gained, but 20 to 100 layers thick graphene were found. The main issue is graphene crystallites which leftover on the substrate are too rare and veiled in pile of thousands thick of graphite flocks.

Subsequent attempt for observation of graphene visibly in optical microscope was placing graphite on Si wafer with attentively prepared thickness of  $\text{SiO}_2$ . However, this method requires particular attendance and perseverance to find graphene. Note that only 5% difference in  $\text{SiO}_2$  may cause single-layer graphene to be invisible. Graphene was lately detected to have a clear vision in Raman microscopy, that makes this technique suitable thickness inspection.

There have been made several endeavours to obtain individual planes of 2D graphene crystals. Nevertheless, the crucial leap of isolating monolayers for assessment of their properties distinctly was never achieved. Recently, by using the approach of Raman microscopy, it is practible to inspect hundreds of different 2D crystals in search of new phenomena and application opportunities [15-17].

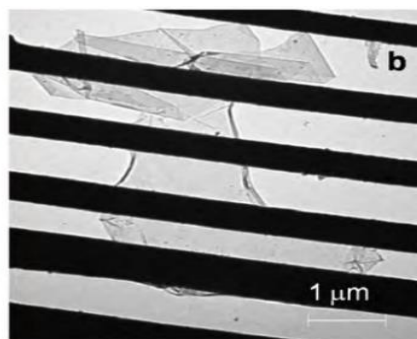
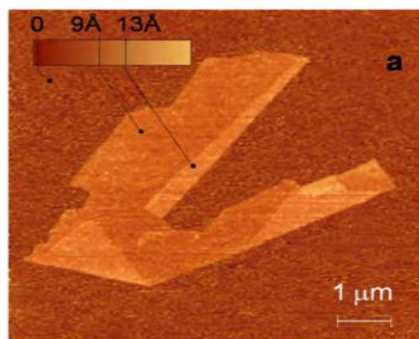

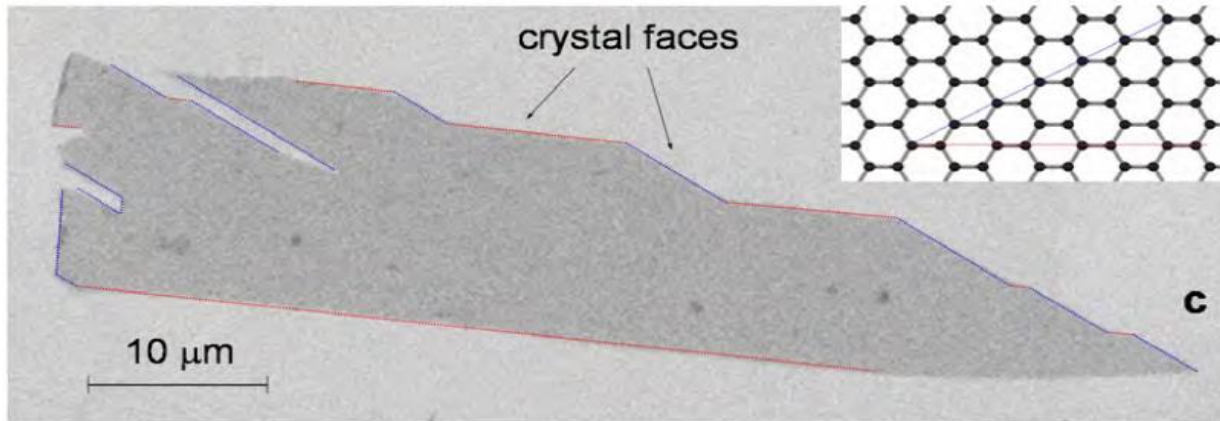

Figure 2. One-atom-thick single crystals: the thinnest material you will ever see. a, Graphene visualized by atomic-force microscopy (adapted from ref. 13,14). The folded region exhibiting a relative height of  $\approx 4\text{\AA}$  clearly indicates that it is a single layer. b, A graphene sheet freely suspended on a micron-size metallic scaffold. The transmission electron-microscopy image is adapted from ref. 24. c, scanning-electron micrograph of a relatively large graphene crystal, which shows that most of the crystal's faces are zigzag and armchair edges as indicated by blue and red lines and illustrated in the inset (T.J. Booth, K.S.N, P. Blake & A.K.G. unpublished). 1D transport along zigzag edges and edge-related magnetism are expected to attract significant attention [2].

## 2. Experimental details

### 2.1 Synthesis and reduction graphene oxide

Numerous of recent methods for the synthesis of GO (Graphene Oxide) are based on the method first offered by Hummers in which graphite is oxidized by a solution of potassium permanganate in sulfuric acid. However, reduction of GO using hydrazine ( $\text{N}_2\text{H}_4$ ) has been reported, because of hydrazine is highly toxic, so, alternative substances as  $\text{NaBH}_4$ , ascorbic acid and HI have been used for reduction of GO. GO can be reduced as a thin film or in an aqueous solution [17-21].

### 2.2 Synthesis of graphene oxide flakes

Azerbaijani scientists (R.G.Abaszade and others.) have synthesized large scale, thin, transparent graphene oxide (GO) flakes by Hummer's method and investigated their suitability for fabrication of transparent nanocomposites. The GO flakes were comprehensively characterized by X-ray diffraction, Scanning Electron Microscopy (SEM), Energy Dispersive X-ray analysis (EDX), Raman spectroscopy and Differential Scanning Calorimetry (DSC). X-ray diffraction displayed the peak of graphene oxide at  $9^\circ$  degree, which is characteristic peak of GO in agreement with the literature results. Scanning Electron Microscopy images revealed that thin, transparent, flake form GO with  $14,8\mu\text{m}$  lateral size and  $0,31\mu\text{m}$  thickness were synthesized. The comparison with literature results show that for the first time, our group could synthesize large scale, thin

and more transparent GO flakes by simple Hummer's method using simple dispersed graphite. EDX measurements indicate the formation of layered structure with oxygen containing functional groups. The intensity ratio between D and G peaks in the Raman spectra proves that less defective GO flakes have been synthesized. The solution ability of the synthesized material indicate that high quality GO flakes were synthesized, which make them effective soluble material due to oxygen containing groups formed on the graphene plane during synthesis process. DSC results shows that these flakes are thermally stable till  $200^\circ\text{C}$ . Due to high solubility properties, large scale and transparency they can be very useful in fabrication of high optical transparent nanocomposites for replacement indium tin oxide transparent conductors in solar panels, biomedical applications and microwave absorbers for electromagnetic interference (EMI) environmental protection [22].

### 2.3 Applications in electronics

Many electronic devices have been fabricated using GO as a starting material for at least one of the components. One such device is a graphene based field effect transistor (GFET). Field effect transistors (FETs) that employ rGO (reduced GO) have been used as chemical sensors and biosensors. A diagram of GFET sensor is shown in Figure 3.

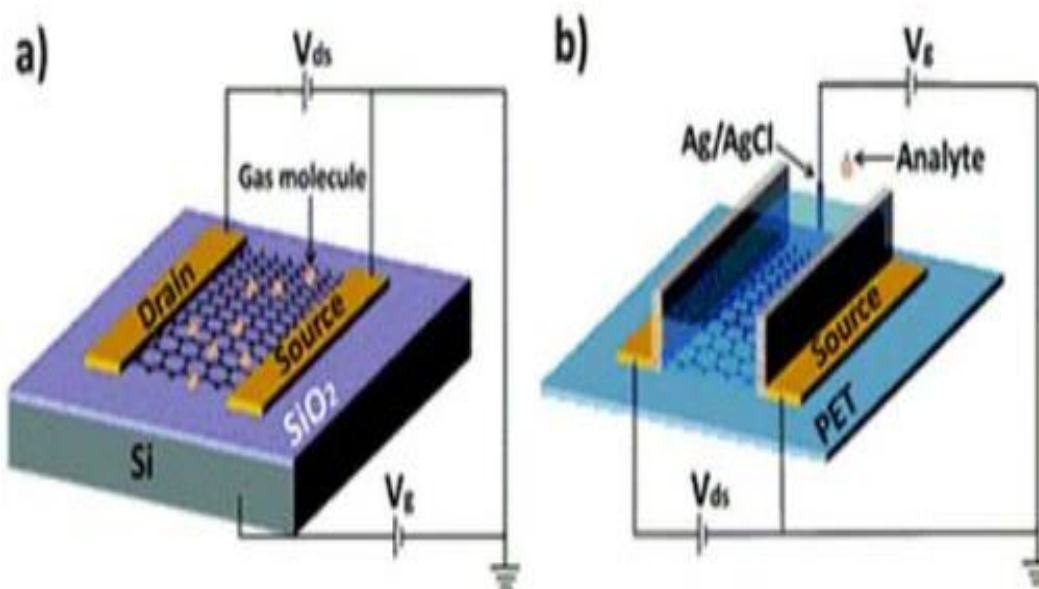

Figure 3. (a) Typical back-gate GFET on Si/SiO<sub>2</sub> substrate used as gas sensor. (b) Typical solution-gate GFET on flexible polyethylene terephthalate (PET) substrate used as chemical and biological sensor in aqueous solution. Reproduced from reference 31 with permission from the Centre National de la Recherche Scientifique (CNRS) and The Royal Society of Chemistry.

Visible light transparent electrodes are important for both light emitting diodes (LEDs) and solar cell devices. Since GO can be processed in solution, using rGO as a transparent electrode is a convenient alternative to other transparent electrodes such as ITO for these devices. In addition to being a transparent electrode, rGO has been used as a hole transport layer in polymer solar cells and LEDs [23,25].

#### 2.4 Energy storage

Nanocomposites of rGO have been used for high capacity energy storage in lithium ion batteries. In these studies, electrically insulating metal oxide nanoparticles were adsorbed onto rGO to increase the performance of these materials in batteries. For example, the energy storage capacity and cycle stability was shown to increase for Fe<sub>3</sub>O<sub>4</sub> on rGO versus pure Fe<sub>3</sub>O<sub>4</sub> or Fe<sub>2</sub>O<sub>3</sub> (Figure 4). High surface area rGO has been made using microwaves for exfoliation and reduction of GO. The high surface area rGO formed is useful as an energy storage material in supercapacitors [25].

#### 2.5 Biomedical applications

One use of GO in the biomedical field is as a component in drug delivery systems. Nanographene

oxide (nGO) has been used in several studies on targeted delivery of anti-cancer drugs. Polyethylene glycol (PEG) functionalized nGO with SN38, a camptothecin derivative, adsorbed onto the surface (nGO-PEG-SN38) was used to as a water and serum soluble source of the drug. In that study, nGO-PEG-SN38 was shown to be three orders of magnitude more effective than irinotecan (CPT-11), an FDA approved SN38 prodrug, at reducing the cell viability of human colon cancer cell lines HTC-116. The effectiveness of nGO-PEG-SN38 was similar to SN38 in DMSO. In a separate study, magnetite was adsorbed onto GO loaded with the anti-cancer drug doxorubicin hydrochloride for targeted delivery of the drug to specific sites using magnets [26].

#### 2.6 Biosensors

GO and rGO have been used as components in several systems designed to detect biologically relevant molecules. GO has been used as a fluorescence quenching material in biosensors which utilize the fluorescence resonance energy transfer (FRET) effect. GO was used as a component used to detect human cervical cancer and human breast cancer cells [27].

### 3. Conclusions

In conclusion, this article has reviewed invention of graphene and its 2D structure; as well as, synthesis and reduction of graphene oxide and its applications as electronic device material and in the field of energy storage. Author has argued that graphene and graphene oxide are going to play very important role as an optimal material due to their hardly two dimensional structure and electronic quality. Writer records that the reality of applications can be acceptable if they carry on commercial purpose and effectiveness, according to researches on graphene`s

### References

- 1.A.K.Geim, K.S.Novoselov, Rise of Graphene. Nanoscience and Technology, pp.11-19, 2009. [https://doi.org/10.1142/9789814287005\\_0002](https://doi.org/10.1142/9789814287005_0002)
- 2.K.S.Novoselov et al., Electric field effect in atomically thin carbon films, Science 306, pp.666-669, 2004. <https://doi.org/10.1126/science.1102896>
- 3.K.S.Novoselov, et al., Two-dimensional atomic crystals, Proc. Natl Acad. Sci. USA 102, pp.10451-10453, 2005. <https://doi.org/10.1073/pnas.0502848102>
- 4.R.G. Abaszade, Analysis of carbon nanotubes, AJP Fizika, Vol.26, №2, section: Az, pp.25-29, 2020. [http://www.physics.gov.az/physart/256\\_2020\\_02\\_25\\_az.pdf](http://www.physics.gov.az/physart/256_2020_02_25_az.pdf)
- 5.S.R.Figarova, E.M.Aliyev, R.G.Abaszade, R.I.Alekberov, V.R.Figarov, Negative Differential Resistance of Graphene Oxide/Sulphur Compound, Journal of Nano Research Submitted, Vol.67, pp.25-31, 2021. <http://dx.doi.org/10.4028/www.scientific.net/JNanoR.67.25>
- 6.R.G.Abaszade, O.A.Kapush, S.A.Mamedova, A.M.Nabiyev, S.Z.Melikova, S.I.Budzulyak, Gadolinium doping influence on the properties of carbon nanotubes, Physics and Chemistry of Solid State, Vol. 21, No. 3, pp. 404-408, 2020. <https://doi.org/10.15330/pcss.21.3.404-408>
- 7.R.G.Abaszade, O.A.Kapush, A.M.Nabiyev, Properties of carbon nanotubes doped with gadolinium, Journal of Optoelectronic and Biomedical Materials, Vol.12, №3, pp.61-65, 2020. [https://www.chalcogen.ro/61\\_AbaszadeRG.pdf](https://www.chalcogen.ro/61_AbaszadeRG.pdf)
- 8.R.A.Namazov, R.G.Abaszade, Properties of graphene based solar panels (review), Ecoenergetics, №1, pp.3-8, 2022.

physical properties it has been proved importance of itself. Besides, synthesis of graphene oxide and its applications as material of chemical sensors and biosensors are mentioned. Additionally, it is highlighted that as a transparent electrode graphene oxide can be processed in the fabrication of LEDs and polymer solar panels. Studies of energy storage capacity has shown that reduced graphene oxide nanocomposites increases the performance of materials in batteries.

- <http://ieeacademy.org/wp-content/uploads/2022/05/ECOENERGETS-JOURNAL-No1.-2022.pdf>
- 9.Kh.M.Popal, R.G.Abaszade, Research and modeling of hybrid energy systems (review), Ecoenergetics, №1, pp.65-69, 2022. <http://ieeacademy.org/wp-content/uploads/2022/05/ECOENERGETS-JOURNAL-No1.-2022.pdf#page=66>
- 10.N.D.Mermin, Crystalline order in two dimensions, Phys. Rev. 176, pp.250-254, 1968. <https://doi.org/10.1103/PhysRev.176.250>
- 11.S.Stankovich, et al., Graphene-based composite materials, Nature 442, pp.282-286, 2006. <https://www.nature.com/articles/nature04969>
- 12.J.C.Meyer, et al., The structure of suspended graphene sheets, Nature, (in press, 2007), 2007. <https://www.nature.com/articles/nature05545>
- 13.H.Shioyama, Cleavage of graphite to grapheme, J.Mat.Sci.Lett.20, pp.499-500, 2001. <https://doi.org/10.1023/A:1010907928709>
- 14.L.M.Viculis, J.J.Mack, R.B.Kaner, A chemical route to carbon nanoscrolls, Science 299, pp.1361, 2003. <https://doi.org/10.1126/science.1078842>
- 15.S.Horiuchi, et al., Single graphene sheet detected in a carbon nanofilm, Appl.Phys.Lett.84, pp.2403-2405, 2004. <http://dx.doi.org/10.1063/1.1689746>
- 16.A.C.Ferrari, et al., Raman spectrum of graphene and graphene layers, Phys.Rev.Lett.97, pp.187401, 2006. <https://doi.org/10.1103/PhysRevLett.97.187401>
- 17.O.C.Compton, S.T.Nguyen, Graphene Oxide, Highly Reduced Graphene Oxide, and Graphene: Versatile Building Blocks for Carbon-Based Materials, Small, 6(6), pp.711-723, 2010.

<http://dx.doi.org/10.1002/sml.200901934>

18.S.Mao, H.Pu, J.Chen, Graphene Oxide and its Reduction: Modeling and Experimental Progress, RSC Adv., pp.22643, 2012.

<https://doi.org/10.1039/C2RA00663D>

19.S.Gilje, S.Han, M.Wang, K.L.Wang, R.B.Kaner, A Chemical Route to Graphene for Device Applications, Nano Lett.. 7(11), pp.3394-3398, 2007.

<http://dx.doi.org/10.1021/nl0717715>

20.S.Pei, H.Cheng, The reduction of graphene oxide, Carbon, 50(9), pp.3210-3228, 2012.

<http://dx.doi.org/10.1016/j.carbon.2011.11.010>

21. Y.Zhu, S.Murali, W.Cai, X.Li, J.W.Suk, J.R.Potts, R.S.Ruoff, Graphene and Graphene Oxide: Synthesis, Properties, and Applications, Adv. Mater., 22(35), pp.3906-3924, 2010.

<http://dx.doi.org/10.1002/adma.201001068>

22.R.G.Abaszade, S.A.Mamedova, F.H.Agayev, S.I.Budzulyak, O.A.Kapush, M.A.Mamedova, A.M.Nabiyev, V.O.Kotsyubynsky, Synthesis and Characterization of Graphene Oxide Flakes for Transparent Thin Films, Physics and Chemistry of Solid State, Vol.22, №.3, pp.595-601, 2021.

DOI: [10.15330/pcss.22.3.595-601](https://doi.org/10.15330/pcss.22.3.595-601)

23.X.Wan, Y.Huang, Y. Chen, Focusing on Energy and Optoelectronic Applications: A Journey for Graphene and Graphene Oxide at Large Scale. Acc. Chem. Res.. 45(4), pp.598-607, 2012.

<http://dx.doi.org/10.1021/ar200229q>

24.X.Huang, X.Qi, F.Boey, H. Zhang, Graphene-based composites, Chem.Soc.Rev.. 41(2) pp.666-686, 2011.

<http://dx.doi.org/10.1039/c1cs15078b>

25.I.V.Lightcap, P.V.Kamat, Graphitic Design: Prospects of Graphene-Based Nanocomposites for Solar Energy Conversion, Storage, and Sensing. Acc. Chem. Res.. 46(10), pp.2235-2243, 2013.

<http://dx.doi.org/10.1021/ar300248f>

26.C.Chung, Y.Kim, D.Shin, S.Ryoo, B.H.Hong, D.Min, Biomedical Applications of Graphene and Graphene Oxide. Acc. Chem. Res.. 46(10), pp.2211-2224, 2013.

<http://dx.doi.org/10.1021/ar300159f>

27.Q.He, S.Wu, Z.Yin, H.Zhang, Graphene-based electronic sensors. Chem. Sci.. 3(6), pp.1764, 2012.

<http://dx.doi.org/10.1039/c2sc20205k>



## **About slope slides expected in the upper level of reservoirs**

**Ch.B.Alizade**

*Azerbaijan University of Architecture and Construction, Baku, Azerbaijan,  
[xelilova.afet@mail.ru](mailto:xelilova.afet@mail.ru)*

**Abstract:** It was investigated the probability of landslides of natural slopes in the upper part of the reservoir. The calculated parameters of the landslide are shown and it is determined that it is related to the fracture eyebrow on the slope.

**Keywords:** Hydro junction, Water mirror square, Water level, Depression curve.

### **1.Introduction**

The rapid development of modern nanoelectronics expands the possibilities of studying and applying new materials [1-7]. Mingachevir Reservoir is our reservoir created at the crossing of the Kura River through Bozdag. Construction of the Mingachevir Reservoir and Hydroelectric Power Station (HPP) was completed in 1953. Mingachevir HPP (Mingachevir Hydroelectric Power Station) is the largest hydropower plant in the South Caucasus. It is located on the Kura River and near the city of Mingachevir. At the normal filling level of the reservoir (83 m), the total water capacity is 15,730 mln. M<sup>3</sup>, and the useful volume is 8210 mln. It is M3. The length of the reservoir along the river varies from 70 km, width from 3 km (dam) to 18 km (at the confluence of the Alazan River). The maximum depth is 75 m, the average depth is 26 m, the length of the coastline is 247 km, and the area of the water mirror is 605 km<sup>2</sup>. The Mingachevir Reservoir is 1550 m long, 16 m wide and 80 m high (one of the tallest dams in Europe).

The installed capacity of Mingachevir HPP, which has 6 hydropower units, is 420 MW, and the average annual electricity production is 1.4 billion kWh. Due to the volume of materials used, it is also the only dam in the world made of gravel and sand.

Separately from the Kura River, the basin supplies water to two canals:

1. 172 km long - Upper Karabakh canal
2. 123 km long -Upper Shirvan canal

These canals are also used to irrigate about a thousand hectares in the Mil, Mugan and Shirvan plains. After the commissioning of the Mingachevir reservoir, it was only fully filled in 1959, 1963, 1968, 1973, 1975, 1976, 1978 and 1988.

The reservoir is also used for fishing, water supply and recreation. At present, the fish fauna of the Mingachevir reservoir consists of 35 species. Of these, 23 species are considered important, and the remaining 12 species are considered non-important. At present, 10-12 species of fish (bream, smelt, smelt, smelt, smelt, smelt, smelt, smelt, smelt) are caught in the reservoir.

Although rare, goldfish, white amura, porcupine and smelt are also found during hunting. In the 50s and 60s, in the ichthyofauna of the Mingachevir reservoir, it was possible to come across not only fish species specific to this river, but also Caspian fish. During these years, sturgeon, Kura ash, Caucasian enlibashi, Khazar shirbit, ordinary gijovchu, Kura chilpakcha, Adi gambuziya, etc. Although it was found one by one, it was found on the same level as Caspian salmon, salmon, Caspian hasham, river fish such as chramulya, zardeper, shirbit, shamayi, poru. During these years, 32 species of fish and one hybrid were recorded in the reservoir. Research in recent years has shown that new species have begun to appear in the reservoir instead of the extinct ones. Heel fish is a spontaneous fish. In the first years of the ichthyofauna of the Mingachevir Reservoir, as mentioned above, fish and other hydrobionts were not yet consolidated in the reservoir due to biological indicators, but after the formation of the reservoir, the composition and reserves of living organisms stabilized. Materials collected and observations made in recent years show the ecology, reserves, hunting dynamics, etc. of the fish living in the current period of the Mingachevir reservoir. allows you to make sufficient additions to the information about.

Sarsang Reservoir is a reservoir built in 1976 on the Tartar River, which belongs to Azerbaijan, in the territory of the former Aghdara, now Tartar region. Its total water capacity is 560 million m<sup>3</sup>, and the height of the dam is 125 m. Sarsang Reservoir is one of the highest dams in the country. The Sarsang Reservoir is currently located in the Tartar (formerly Aghdara) region and is operated by Azerbaijan. The Sarsang reservoir provided irrigation water to about 100,000 hectares of land in 6 regions of the country (Tartar, Agdam, Barda, Goranboy, Yevlakh and Agjabadi). As a result of the occupation of the Sarsang reservoir alone, the failure to provide irrigation water to 100,000 hectares of agricultural crops has caused irreparable damage to this region of the republic. Currently, the reservoir and its facilities have been under occupation for more than 10 years and are in a state of emergency due to lack of maintenance. For this reason, the Sarsang reservoir poses a serious threat to the population located in its lower bay. However, the liberation of the warehouse from occupation creates conditions for its restoration. After a number of repairs, the warehouse will return to its previous state and provide our areas with irrigation water [8,9].

## **2. Experimental details**

Khudafarin Reservoir is a reservoir built on the Araz River, located on the international border between Iran and Azerbaijan. The reservoir was built on the Araz River in accordance with the agreement signed between Iran and Azerbaijan. It is the third largest reservoir in Azerbaijan in terms of capacity and volume. It is planned to irrigate 75,000 hectares through the reservoir. It is located 8 km west of Khumarli village in eastern Azerbaijan and 1 km northwest of Khudafarin village in Azerbaijan's Jabrayil region. covers the territory. From 1993 to October 18, 2020, the reservoir was under the control of the Republic of Armenia together with the Hydroelectric Power Station of the same name.

Takhtakorpu reservoir is a reservoir belonging to the Samur-Absheron irrigation system. It was built in the Shabran region of the Republic of Azerbaijan as part of the Samur-Absheron irrigation system reconstruction project. Construction began in 2007. The water taken from the Samur River flows into the Takhtakorpu Reservoir through the Valvalachay-Takhtakorpu canal. The area of the Takhtakorpu reservoir is 8.71 km<sup>2</sup>. The total water capacity of this facility is 270 million m<sup>3</sup>. The useful water volume of the lake is 238.4 million m<sup>3</sup>. This hydraulic structure

with a clay core is 754 meters wide and 142.5 meters high. Takhtakorpu Reservoir is the tallest dam in Azerbaijan. Buddha is one of the highest dams not only in the region, but also in Europe. The length of the emergency water intake here is 891 meters, the length of the intake facility is 43.6 meters, and the length of the power tunnel is 543 meters. The door shaft is 56 meters deep. A modern lighting system has been installed here, and asphalt has been laid on the roads in the area. Large-scale landscaping and landscaping works have been carried out along the road from the Baku-Russian Federation state border highway to the Takhtakorpu reservoir, as well as throughout the area. More than 23 million cubic meters of earthworks have been carried out on the body of the Takhtakorpu reservoir dam alone.

Very complex slope events occur in the upper part of the reservoirs of the reservoir built and put into operation. These slope landslides differ from each other. The strong winds in the area increased the length and height of the waves in the reservoir, and the washing away of the coastal slopes caused abrasive landslides and avalanches. It is still of strategic importance for the Republic of Azerbaijan and the Republic of Georgia, as well as for the Russian Federation. Therefore, any research and studies related to this hydro junction should be considered important. Thus, in the 90s of the last century, studies were conducted on landslides in the foothills of Bozdag on the right bank of the Mingachevir reservoir, engineering measures were taken, and there is still a need to continue this work. The process of landslides at the foot of the Bozdag has affected the flora and fauna of the area, the landslide has entered the reservoir, changed its volume, affected water quality and, in general, caused some damage to the ecological environment of the area.

The Sarsang Reservoir, one of the other high-pressure and large hydro junctions in the country, was built on the Tar-Tar River. In order to prevent such environmental problems, the water level in the reservoir was lowered and certain slope stabilization works were carried out in the upper bay to prevent such environmental problems.

One of the environmental problems on the very hard and unstable structural slopes of reservoirs is that such slopes are subject to collapse due to the effects of water from the upper bay. After the construction of the hydro junction, avalanches occur on these slopes. Although these avalanches sometimes occur in the same form, the processes also take different forms. As

a result of "plastic displacements" of deformable soils, the bottom of these solid rocks becomes empty, causing them to collapse. same high with When there are hard coastal slopes in the cliff, as a result of a strong ripple process, the sediments wash away the unstable structural (sandy) soils on those slopes and pour them into the reservoir, which causes the topsoil to break up and fall into the reservoir. Therefore, reservoirs with steep slopes always face environmental problems.

### **3. Conclusions**

Taking into account the fact that the slopes of the upper reaches of the hydro junctions are under water pressure, they can be calculated in 3 cases: [a; b; c]:

a) In the first case, the landslide-prone part of the slope is completely submerged and the leakage gradient is determined taking into account the entire landslide surface;

b) in the second case, a certain part of the slope is flooded and the leakage gradient is found according to the geometric location of the beginning and end points of the depression curve of the leakage flow on the slope of the slope;

c) In the third case, the water level falls suddenly (suddenly) at a great depth along the slope and a backflow of water from the slope to the reservoir is observed, in which case the calculation scheme is adopted according to the stabilized moment of the backflow process. purchase is very important.

The most important of the studies to be carried out on the upper slopes of reservoirs is to predict the expected slope slopes scientifically and theoretically. It is very rare on the upper slopes of the reservoir that such landslides are inevitable in every reservoir. Such landslides are very dangerous. Proper study is of great importance, which can be achieved by correctly locating the fracture eyebrow on a sloping slope.

### **References**

1.R.G.Abaszade, S.A.Mamedova, F.H.Agayev, S.I.Budzulyak, O.A.Kapush, M.A.Mamedova, A.M.Nabiyev, V.O.Kotsyubynsky, Synthesis and Characterization of Graphene Oxide Flakes for Transparent Thin Films, Physics and Chemistry of Solid State, Vol. 22, No. 3, pp. 595-601, 2021.

[DOI: 10.15330/pcss.22.3.595-601](https://doi.org/10.15330/pcss.22.3.595-601)

2.S.R.Figarova, E.M.Aliyev, R.G.Abaszade, R.I.Alekberov, V.R.Figarov, Negative Differential Resistance of Graphene Oxide/Sulphur Compound, Journal of Nano Research Submitted, Vol.67, pp. 25-31, 2021.

<http://dx.doi.org/10.4028/www.scientific.net/JNanoR.67.25>

3.R.G.Abaszade, O.A.Kapush, S.A.Mamedova, A.M.Nabiyev, S.Z.Melikova, S.I.Budzulyak, Gadolinium doping influence on the properties of carbon nanotubes, Physics and Chemistry of Solid State, Vol. 21, No. 3, pp. 404-408, 2020.

<https://doi.org/10.15330/pcss.21.3.404-408>

4.R.G.Abaszade, O.A.Kapush, A.M.Nabiyev, Properties of carbon nanotubes doped with gadolinium, Journal of Optoelectronic and Biomedical Materials, Vol.12, №3, pp.61–65, 2020.

[https://www.chalcogen.ro/61\\_AbaszadeRG.pdf](https://www.chalcogen.ro/61_AbaszadeRG.pdf)

5.R.G.Abaszade, Analysis of carbon nanotubes, AJP Fizika, Vol.26, №2, section: Az, pp.25-29, 2020

[http://www.physics.gov.az/physart/256\\_2020\\_02\\_25\\_az.pdf](http://www.physics.gov.az/physart/256_2020_02_25_az.pdf)

6.Kh.M.Popal, R.G.Abaszade, Research and modeling of hybrid energy systems (review), Ecoenergetics, №1, pp.65-69, 2022

<http://ieeacademy.org/wp-content/uploads/2022/05/ECOENERGETS-JOURNAL-No1.-2022.pdf#page=66>

7.R.A.Namazov, R.G.Abaszade, Properties of graphene based solar panels (review), Ecoenergetics, №1, pp.3-8, 2022

<http://ieeacademy.org/wp-content/uploads/2022/05/ECOENERGETS-JOURNAL-No1.-2022.pdf>

8.Sh.B.Khalilov, Dynamics of shores of the large reservoir of the Azerbaijan SSR Baku: "Elm" publishing house, 90 p., 1979.

9.K.M.Mammadov, Z.S.Musayev, T.M.Mahmudov, A.A.Mursalov, Research of slope stability issues, Baku: "Education" NPM, 188p., 2006.

## **Structured work of intelligent network technology**

**T.M.İsayeva, G.İ.Asgerova**

*Azerbaijan State University of Oil and Industry, Baku, Azerbaijan,  
[tarana.isa@gmail.com](mailto:tarana.isa@gmail.com), [gulare\\_esgerova@mail.ru](mailto:gulare_esgerova@mail.ru)*

**Abstract:** When energy consumption is high, ways to solve real problems arising in the timely production, conversion and transmission of energy have been investigated. In order to use energy more efficiently and effectively, a number of studies have been conducted on intelligent networks, which are perceived as new generation electrical systems. It has been shown that intelligent network technology significantly changes energy consumption by proven testing. It allows you to make great progress in the management, transmission and distribution of energy. The proposed method provides real-time monitoring, tracking and power control.

**Keywords:** Power generation, Energy management, Sensor network, Intelligent networks, System.

### **1.Introduction**

The intelligent network technology system is a very important tool for providing extensive information on energy consumption to residents, housing, commercial, educational and enterprises.

The problem solutions of this energy management range from automatic management of the power grid system to advice on the use of the human-operator as a transmitter.

### **2. Experimental details**

It is always necessary to control power, voltage, frequency and other parameters in electrical networks. Intelligent networks were used in the 1970s and 1980s to re-send consumer information to the network [7]. But now the main issue is efficient, reliable, high-quality and uninterrupted transmission of electricity. Intelligent network technology helps to eliminate it, detecting any defects. The most important advantage is remote control of the network, eliminating losses and significantly saving time.

According to the information provided by the electricity Research Institute, the most difficult problem of the intellectual network is cybersecurity. This technology ensures the economical use of electricity by the consumer.

One of the most important features of intelligent networks is that the consumer has an advanced measurement infrastructure used for power quality, data collection, and analysis. It is considered expedient to design and implement advanced

t is a major problem that the system processes a large number of sensor data, as well as responds to a large number of requests in sufficient time. Solving this problem using the functional database method allows you to separate the higher-level query into lower-level queries and consolidate the results using the service composition [2].

The first studies on intellectual networks cover the planning of Future Energy Networks for the interaction of production centers and consumers [4]. metering infrastructure for single-phase electrical networks of this system [6].

Advanced power electronics, sensor and measurement technologies, as well as power management and demand control require the development of Smart networks [5].

As well as operational monitoring with the application, energy production can be monitored through solar panels.

The applied system consists of 2 main parts - CASR25-NP current sensor [1] and MCP6002 operational amplifier [3]. This current sensor is capable of detecting current and impulse signals directly. Another positive feature is that it has galvanic isolation of up to 4.1kV between the input and output. The operating amplifier has an electrostatic protective voltage limit of up to 4kV and two independent circuits in one case. The most important feature of the applied system is that it is able to control the entire network with only 5V voltage instead of the required  $\pm 15V$  symmetrical supply voltage [9].

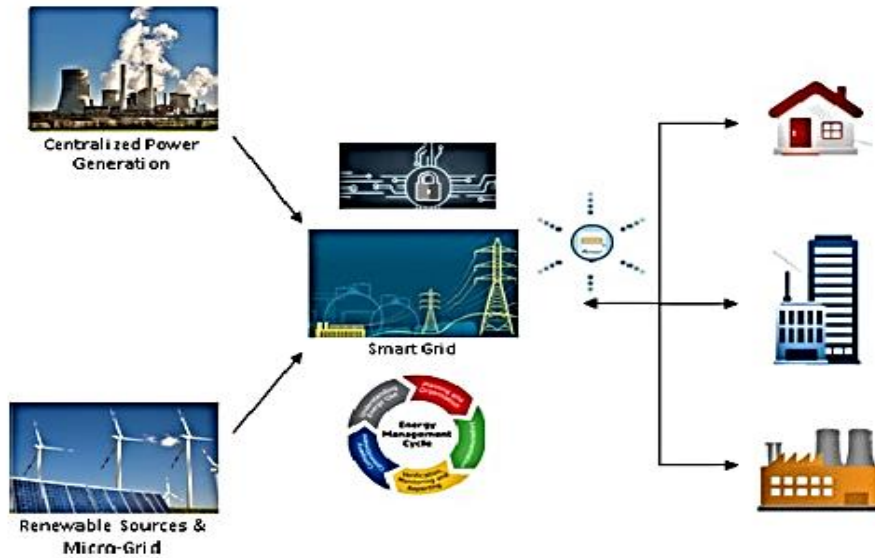

Figure 1. Description of intelligent network technology

This system has been applied for correction, conversion, transmission and processing of signals. For the implementation of the system, a simulation program of the Proteus signal processing system was used during the monitoring. The processing stages of the signal processing system are, first of all, the editing of digital signals, the transfer of

microcontroller to a data communication module using a universal asynchronous receiver/transmitter block. Microchip company's 18f4620 microcontroller is used to perform these operations [7,8]. Modern advances in science and technology have increased the opportunities for the study and application of nanomaterials [10-16].

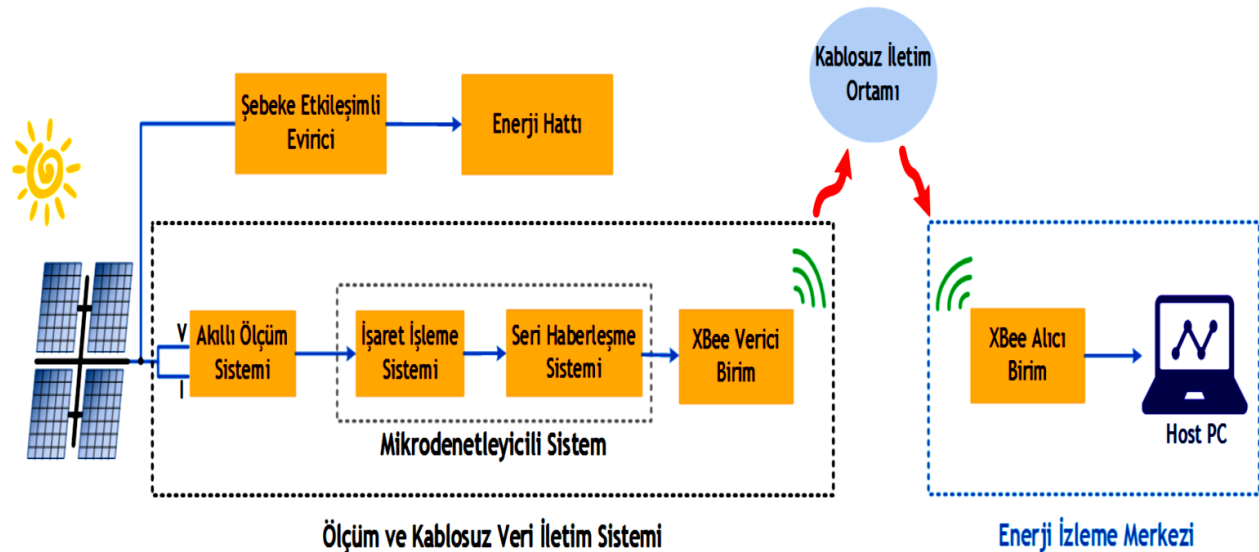

Figure 2. Power tracking system designed for intelligent networks

The main purpose in this system is to monitor the current, voltage, volume of electricity, and losses of

solar panels. Wireless communication is transmitted to the power monitoring center, i.e. to the receiving

unit. This tracking center includes a PCB antenna Xbee Pro s2c module. This module, as the coordinator of the communication system, connects to the computer with USB, where viewing and data storage will be performed.

In order to receive the result signal of operations from the signals obtained from the receiver Xbee module PCB antenna, decoding and demodulation processes are performed in the first place. After all these processes, the measurement data obtained is transmitted to the computer via a USB port in the form of a signal. Receiving measurement data from these signals coming to the computer, to implement real-time monitoring of Microsoft visual studio.net the software is designed using the C# programming language.

The process consists of two main operations:

1. Storage of including data the local computer from the receiver Xbee module;
2. Storing data in the database.

The process of storing data in a database is carried out through Microsoft Acces software. It also has the ability to synchronize two systems simultaneously.

The solar panel used in the studied system has a power of 250W and its maximum power voltage is 29,98 v, its current at maximum power is 8,34A, and the short circuit current is 8,79A. As shown in Figure 3, the system interface marked two different indicators. The first shows the measured prices, the second shows the graphical changes. The indicators used in the interface give the change in the power that the solar panel produces per hour, which is used to change the instantaneous measurement data in real time.

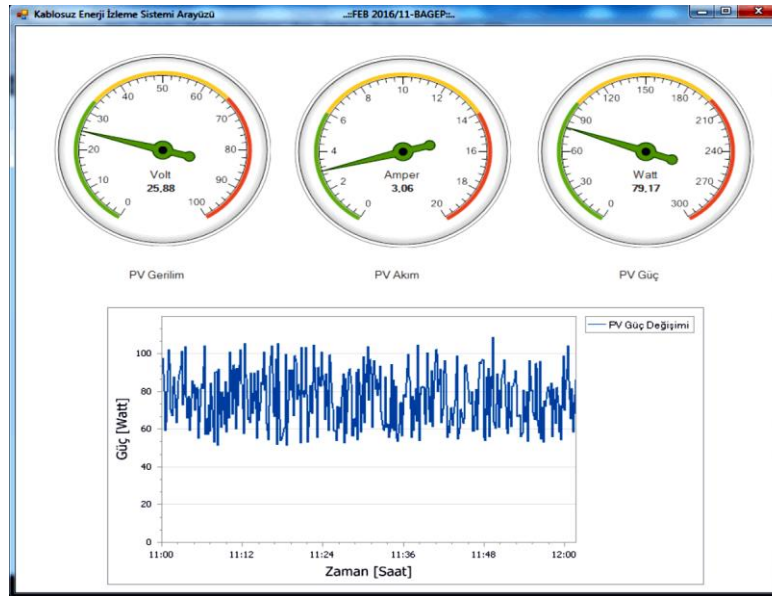

Figure 3. Interface of remote monitoring software

The issues of structure and application of intelligent measurement system and remote control system in real time providing structured work of intelligent network technology were solved. This technology increases the reliability and quality of electricity supply, and the system itself ensures the detection of prices of current and voltage with reasonable error. Its main advantages are that it works with a single source, is economically profitable and creates a cost-effective network system.

### 3. Conclusions

The communication infrastructure of the proposed system was realized using the Zig Bee communication protocol. This infrastructure works with the X bee communication module. This module is very easy to use, program and has low energy costs. Real-time monitoring of parameters, model results of the intelligent measurement system show that from it it is possible to effectively control the current, voltage, power, frequency of solar panels and timely intervene in the resulting defects..

## References

- 1.Current transducer CASR series Datasheet, <https://goo.gl/Hhnaa1>
- 2.D.Marrero, A.Suárez, E.Macías, V.Mena, Extending the Battery Life of the ZigBee Routers and Coordinator by Modifying Their Mode of Operation, 2019.  
[doi: 10.3390/s20010030](https://doi.org/10.3390/s20010030).
- 3.MCP6001/1R/1U/2/41 MHz, Low-Power Op Amp, <https://goo.gl/MKv4cm>.
- 4.M.Goulden, B.Bedwell, S.Rennick-Egglestone, T.Rodden, A.Spence, Smart grids, smart users The role of the user in demand side management. Energy Research & Social Science, 2, pp.21-29, 2014.  
<https://doi.org/10.1016/j.erss.2014.04.008>
- 5.M.Sechilariu, B.Wang, F.Locment, Building-integrated microgrid: Advanced local energy management for forthcoming smart power grid communication. Energy and Buildings, 59, pp.236-243, 2013.  
<http://dx.doi.org/10.1016/j.enbuild.2012.12.039>
- 6.P.Siano, Demand response and smart grids-A survey. Renewable and Sustainable Energy Reviews, 30, pp.461-478, 2014.  
<http://dx.doi.org/10.1016/j.rser.2013.10.022>
- 7.The History of Making the Grid Smart. Available: [https://ethw.org/The\\_History\\_of\\_Making\\_the\\_Grid\\_Smart](https://ethw.org/The_History_of_Making_the_Grid_Smart). SmartGrids E. SmartGrids strategic deploy (01-10-2018).
- 8.Y.Kabalci, A survey on smart metering and smart grid communication. Renewable and Sustainable Energy Reviews, 57:5, pp.302-318, 2016.
- 9.Y.Kabalci, E.Kabalci, A low cost smart metering system design for smart grid applications. 8th International Conference on Electronics, Computers and Artificial Intelligence (ECAI 2016), Ploiești, Romania, pp. EC&E 1-6, 30 June-02 July 2016
- 10.R.G.Abaszade, S.A.Mamedova, F.H.Agayev, S.I.Budzulyak, O.A.Kapush, M.A.Mamedova, A.M.Nabiyev, V.O.Kotsyubynsky, Synthesis and Characterization of Graphene Oxide Flakes for Transparent Thin Films, Physics and Chemistry of Solid State, Vol.22, No3, pp. 595-601, 2021.  
[DOI: 10.15330/pcss.22.3.595-601](https://doi.org/10.15330/pcss.22.3.595-601)
- 11.S.R.Figarova, E.M.Aliyev, R.G.Abaszade, R.I.Alekberov, V.R.Figarov, Negative Differential Resistance of Graphene Oxide/Sulphur Compound, Journal of Nano Research Submitted, Vol. 67, pp. 25-31, 2021.  
<http://dx.doi.org/10.4028/www.scientific.net/JNanoR.67.25>
- 12.R.G.Abaszade, O.A.Kapush, S.A.Mamedova, A.M.Nabiyev, S.Z.Melikova, S.I.Budzulyak, Gadolinium doping influence on the properties of carbon nanotubes, Physics and Chemistry of Solid State, Vol.21, №3, pp.404-408, 2020.  
<https://doi.org/10.15330/pcss.21.3.404-408>
- 13.R.G.Abaszade, O.A.Kapush, A.M.Nabiyev, Properties of carbon nanotubes doped with gadolinium, Journal of Optoelectronic and Biomedical Materials, Vol.12, №3, pp. 61-65, 2020.  
[https://www.chalcogen.ro/61\\_AbaszadeRG.pdf](https://www.chalcogen.ro/61_AbaszadeRG.pdf)
- 14.R.G.Abaszade, Analysis of carbon nanotubes, AJP Fizika, Vol.26, №2, section: Az, pp.25-29, 2020.  
[http://www.physics.gov.az/physart/256\\_2020\\_02\\_25\\_az.pdf](http://www.physics.gov.az/physart/256_2020_02_25_az.pdf)
- 15.Kh.M.Popal, R.G.Abaszade, Research and modeling of hybrid energy systems (review), Ecoenergetics, №1, pp.65-69, 2022.  
<http://ieeacademy.org/wp-content/uploads/2022/05/ECOENERGETS-JOURNAL-No1.-2022.pdf#page=66>
- 16.R.A.Namazov, R.G.Abaszade, Properties of graphene based solar panels (review), Ecoenergetics, №1, pp.3-8, 2022.  
<http://ieeacademy.org/wp-content/uploads/2022/05/ECOENERGETS-JOURNAL-No1.-2022.pdf>

## **Methodology of application of new information technologies in mathematics course in higher technical schools**

**I.Y.Bayramov**

*Azerbaijan State University of Oil and Industry, Baku, Azerbaijan,  
[imranb1963@mail.ru](mailto:imranb1963@mail.ru)*

**Abstract:** Methodological foundation of teaching together with the realization of new information technology into the mathematics course in the institutes of higher education. The rapid development of new information technologies, appearance of the systems of computer mathematics and enhancement of using in educational activities have led to the changing of the objectives and goals in the high mathematics course teaching. That is, the analysis of the objectives and goals of high mathematics course teaching in the institutes of higher education in the modern conditions favored the appearance of the idea of modernization of the methods and strategy of high mathematics teaching.

**Keywords:** Mode simulator, Modernization, Computer textbook, Principal aspects.

### **1.Introduction**

One of the latest achievements of science is increasing the opportunities for the study and application of graphene-based nanomaterials [1-16].

Recently, the penetration of new information technologies in the field of education has become commonplace. As a result, changes in the methods of teaching subjects in universities have become necessary.

One of the methodological support of the teaching process in mathematics is computerized textbooks.

Computer (electronic) textbook - is a computer tool for teaching the basic preparation of a certain subject, characterized by the relative completeness of the content and in the form of a textbook (book) on electronic media. That is, a computer textbook is a textbook created and used with the help of a computer to learn the norms of the course and stored in the computer's memory.

Let's determine the place of the computer textbook in the teaching process.

A computer textbook on higher mathematics should be aimed at expanding the teaching of mathematics. The use of computer textbooks does not mean the suppression of traditional forms of teaching mathematics. Computer textbook is a culture of mathematical reasoning, confident mastery of standard methods of mathematical proof, simple and independent use of commonly known algorithms, the ability to create and apply new algorithms, etc. is

intended as an additional tool for the formation of such habits.

The computer textbook provides the user with an environment for the normal process of working on mathematical materials, and the student (learner) can do the following:

- to see abstract mathematical objects and their connections;
- to clarify the principal aspects of formal theorems and methods of mathematical research;
- Acquisition of basic mathematical skills with the help of a simulator in a computer textbook;
- The computer must test its ability to solve problems similar to the ones shown in the textbook, as well as more complex ones, including those that require proof.

The computer textbook allows students to focus on the principal aspects of the question being studied, rather than on tedious calculations (because such calculations are performed automatically).

Those who study mathematics through a computer textbook can use it for the following purposes:

- as an individual teacher-consultant;
- as an exercise machine that develops mathematical skills;
- as a means of self-examination;
- as an information book on mathematics.

A math teacher can use a computer textbook to test students' knowledge and conduct lively creative



sessions with students, for which he or she must assign the computer to the initial stage of learning.

The computer textbook environment naturally models the learning process. It is advisable to place the table of contents at the beginning of the computer textbook, but there should be hyperlinks instead of page numbers of these or other sections or paragraphs. So, the content of the computer textbook shows the menu of sections, chapters and paragraphs according to the structure of the teaching material - a hierarchical tree of sections.

When working on a learning material using a computer textbook, the user can use the following five learning modes simultaneously or in turn:

- a) Theoretical regime;
- b) Images and sample mode;
- c) Mode simulator;
- d) Issue mode;
- e) Dictionary of words (glossary).

Many users of computer textbooks point out that it is not necessary to create mode menus, arguing that computer textbooks designed in Mathematica do not need to specifically select one mode or another, because the system is a universal interpreter and all modes are interconnected. This means that the user can easily switch from one mode to another without performing additional operations.

## **2. Experimental details**

**Theory mode.** A computer textbook or any textbook should have an information system with basic definitions for easy use, a description of the properties of mathematical objects, course judgments and theorems, a description of algorithms. The computer textbook uses hyperlinks to conveniently describe the structure of theoretical material. If a computer textbook could only read teaching material on a computer screen, it would not be possible to completely replace and complete a traditional textbook.

The hyperlinks system makes it easier to include theoretical materials in a computer textbook and use them than a traditional textbook. However, these advantages do not determine whether the theory mode plays an important role in the computer textbook. This mode only plays a supporting role in the computer manual.

**Images and sample mode.** Practically every mathematical subject needs a geometric description of mathematical abstractions. Geometric image animation can also be used to improve comprehension of key objects, facts, and algorithms. The computer

textbook creates these features in the form of pictures and examples. In this mode, certain "knowledge atoms" are depicted in the form of compact graphic descriptions - labels, and their appearance on the computer screen at any time creates the necessary images in the student's memory.

The mode of pictures and samples can be attributed to the means of the first stage of training.

**Exercise mode.** This mode is used in the next stage of training. This mode is used for the student (learner) at the stage of solving tasks in accordance with the tasks in traditional textbooks, answering simple questions from theory. In the computer manual, this mode is performed in a hidden slot, and only one entry and exit to the simulator is possible. The test questions of the simulator are located in this slot, and not all questions appear on the screen at the same time. The questions appear on the screen one after the other, and note that only after the correct answer to the question, the next question appears on the screen. The main goal of the student who uses the simulator is to enter the simulator and get out of it, overcoming the difficulties encountered in the form of problems. If a student goes through a simulator in a computer class with the participation of a teacher, he can create his own special computer textbook, expressing the teaching material in his own way.

Computer textbooks developed with the application of any computer mathematics system are a key tool in the teaching of higher mathematics as a new information technology (especially in the organization of independent work of students). Let's define the main provisions of this methodology applied to the higher mathematics course.

First of all, let's determine the structure of teaching materials from higher mathematics to the application of the computer mathematics system and compile a program of relevant topics:

1. Matrices and determinants. Linear algebra.
  - 1) Actions on matrices. Calculation of determinants.
  - 2) Linear vector spaces and their sub-spaces.
2. Analytical geometry.
  - 1) The theory of two-order curves.
  - 2) The theory of two-order surfaces.
  - 3) Study of curves with polar coordinates. Surface and its equation.
3. The theory of limits.
  - 1) Limit of sequence. Sequence visualization.
  - 2) Limit of the function. Calculation of limits.
4. Differential calculus and its applications.
  - 1) Differentiation of function.

2) The study of a function with a real argument. Visualization of a function with its derivative; construction of the graph of the function and its derivatives.

5. Integrated account and its applications.

1) Calculation of indefinite and definite integrals. Visualization of the solution.

2) Calculation of multiple integrals.

3) Calculation of double and triple integrals. Visualization of the solution.

4) Calculation of curvilinear integral. Visualization of the solution.

5) Applications of integral calculus to geometry and physics. Visualization of the solution.

6. Rows.

1) Study of the assembly of rows. Special sums of assembled rows and visualization of sums of rows.

2) Taylor and Macleron series. Visualization of a function and a polynomial that approximates the function obtained and given as a special sum of Taylor's sphere.

7. Differential equations.

1) Solution of differential equations. Cauchy issue. Visualization of the solution of the Cauchy problem; graph of the dependence of the solution on the initial conditions (by comparing different options).

2) Approximate solution of the Cauchy problem for single and high-order differential equations. Visualization of the solution. Examples of analytical use of interpolation functions that provide an approximate solution to the Cauchy problem.

Since these topics require heavy calculations, it is advisable to automate them. Virtually any of the above should be presented in almost complete theory using a computer, not a computer. It is advisable to compile computer textbooks covering these topics and use them in classroom lessons (as well as lectures), in the preparation of independent homework (problem solving) in extracurricular activities, and in the study of theory in combination with the practical part.

New information technologies in the teaching of higher mathematics in technical universities are based on computer mathematics systems, as they are based on traditional content, and require the use of unsystematic combinations of classical and modernized forms and methods of teaching. Modernized forms of learning require the creation of one or more of the following forms of learning using computer mathematics systems:

1) educational computer programs;

2) computer simulators;

3) computer control programs;

4) Computerized textbooks and problem books;

5) Computer (electronic) textbooks and problem books.

The final form of the pedagogical software product combines the properties of the above four.

Computer textbooks are integrated software products that combine training, control programs, and a simulator and computer guide. Therefore, let's explain the components of these textbooks.

The methodological basis of a computer textbook in higher mathematics is that its practical part consists of programs designed in a functional style designed to solve supporting problems (typical problems that are often used in solving other problems). An example is the calculation of special sets of arbitrary limits of a series and several special sets that approximate the function itself by visualizing the coefficients of the Fourier series of a function of a real variable and the graph of the function. These programs should be designed so that the student can check the correctness at any stage while independently solving the problem assigned to him (or by him). In addition, each step of the program must be explained in detail.

It is also possible to design simulators that automatically check the correctness of the solution by a computer, and then evaluate it by a computer. However, this work is a waste of time for computer textbook developers. It should be noted that this part (mainly automated quality control of students' knowledge) is not so important for the first version of the computer textbook. Because the structure of the program created in KRS is such that the student can check the correctness of his solution at each step using the solution steps provided by the computer.

The task of creating fully automated simulators is to regularly collect a bank of simulators and compile them with developed samples.

Thus, the methodological organization of the teaching of higher mathematics with the application of new information technologies is based on the use of computer textbooks developed by teachers and students in the CRS environment. Assessment of mastery is carried out with the help of tests (or the usual written, which is checked by the teacher or with the help of a computer). Questions should be formulated in accordance with what students have learned independently from computer textbooks, and they should be included in course exams.

The method of teaching using the computer mathematics system can be considered as a method of organizing and implementing the student's teaching

and comprehension activities. This method refers to visual and practical methods according to the source of transmission and reception of information, as it allows to demonstrate the studied objects, to give its image and to solve mathematical problems. Logically, the transmission and reception of educational information is a deductive method. Because first the general solution of certain types of problems is shown, and then concrete examples are considered. Depending on the degree of free thinking of the student during the acquisition of knowledge, this method has functions such as seeker (allows students to build certain relationships) and researcher (allows a comprehensive study of the mathematical object). According to the degree of management of learning activities, this method is aimed at activating the independent activities of students, and one of the forms of its implementation is practical work with the use of computers.

The main purpose of this method is to create a learning process by the teacher in such a way as to ensure that students actively master the materials of the higher mathematics course and the formation of their independent creative cognitive activities. It should be noted that each training method has meaningful and formal aspects. The significant aspect of the method consists of the following components:

- a) the type of reflection of the training activity;
- b) substantive characteristics of the main and auxiliary training tools;
- c) the relationship between the main and ancillary training products;

The formal side of the training method consists of two groups of components:

- a) basic teaching aids (definite and indefinite formulation of problems according to their degree of difficulty);
- b) the form of management of training activities.

The type of reflection of the learning process is determined by which knowledge and activity is a direct product of learning. Learning to solve mathematical problems (computational operations, graphing, etc.) is a direct learning product. Ancillary learning products include the development of computer mathematics skills and the thoughtful actions necessary for students to master meaningful learning activities.

Basic and auxiliary learning tools determine students' level of independent understanding. Relationships between cognitive issues, didactic perception and cognitive activity can be considered as a high level of independent cognitive activity. The teaching method

with CRS is aimed at students to independently ask questions of understanding, to independently determine and predict their solutions, to evaluate the results. It can be concluded that training with CRS is one of the main training tools.

There are two aspects to assistive learning tools. The first aspect is designed to solve a specific learning problem, in which case the CRS is to perform accurate calculations, graphically describe the solution found, and so on. applies to. The second aspect is to eliminate the causes of the difficulties faced by students in solving certain problems. In this case, it is a matter of correcting the errors that occur when entering incorrectly the commands of the CRS language. In the first case, the student carries out a certain stage of solving the problem with CRS. In the second case, the student is helped to improve his skills in working with CRS.

The most important component of the content of the training method is the relationship between the main and ancillary products of the training. It should be noted that it is impossible to solve mathematical problems on a computer without the skills of working with KRS, and vice versa, it is impossible to work with KRS without knowing the basics of mathematics. Research shows that the by-product is remembered and mastered more quickly than the main product, so it is important to set the goal of learning what is needed to solve the problems of the university course, not all the capabilities of the CRS.

The formal aspect of this training method is related to the explicit or implicit presentation of the training question. For example, when solving a system of equations with the help of KRS, it is advisable to use the Solve function, because the answer is obtained immediately after the application of the function. This is a clear statement of the issue. Inexplicably, the problem includes problems whose solution provides the solution of obvious problems, ie it is used in solving obvious problems, for example, operations on the coefficients of linear equations, etc. an example can be shown.

The main feature of the formal aspect of this training method is the relationship between the levels of difficulty of the training issues. The difficulty of a training problem is the probability of solving the problem correctly and the function of two variables depending on the time spent on the solution. If the student knows CRS perfectly, then the probability of the right solution increases. Problem solving time is the time a student spends looking for and thinking about a solution. Once the correct solution to the

problem has been found by the student and the solution has been correctly interpreted in the CRS, the solution of the problem is completed in a matter of seconds.

The main form of organization of training with the help of CRS is the conduct of practical classes in a computer classroom with the use of computers. The learning process, aimed at forming a system of

### 3. Conclusions

This model is one of the modernized models of the educational process and is based on the following principles: Training should begin not in particular, but in general, not in parts, not in elements, not in elements. The training should be applied from the general to the basis, from the whole, from the structure to the specific, to the details, parts, elements. Establishment of the system of teaching subject with logical explanation and concretization of the meanings of the basic principles and concepts.

### References

- 1.R.G.Abaszade, S.A.Mamedova, F.H.Agayev, S.I.Budzulyak, O.A.Kapush, M.A.Mamedova, A.M.Nabiyev, V.O.Kotsyubynsky, Synthesis and Characterization of Graphene Oxide Flakes for Transparent Thin Films, Physics and Chemistry of Solid State, Vol. 22, No. 3, pp. 595-601, 2021.  
[DOI: 10.15330/pcss.22.3.595-601](https://doi.org/10.15330/pcss.22.3.595-601)
- 2.S.R.Figarova, E.M.Aliyev, R.G.Abaszade, R.I.Alekberov, V.R.Figarov, Negative Differential Resistance of Graphene Oxide/Sulphur Compound, Journal of Nano Research Submitted, Vol.67, pp. 25-31, 2021.  
<http://dx.doi.org/10.4028/www.scientific.net/JNanoR.67.25>
- 3.R.G.Abaszade, O.A.Kapush, S.A.Mamedova, A.M.Nabiyev, S.Z.Melikova, S.I.Budzulyak, Gadolinium doping influence on the properties of carbon nanotubes, Physics and Chemistry of Solid State, Vol.21, №3, pp.404-408, 2020.  
<https://doi.org/10.15330/pcss.21.3.404-408>
- 4.R.G.Abaszade, O.A.Kapush, A.M.Nabiyev, Properties of carbon nanotubes doped with gadolinium, Journal of Optoelectronic and Biomedical Materials, Vol.12, №3, pp.61–65, 2020.  
[https://www.chalcogen.ro/61\\_AbaszadeRG.pdf](https://www.chalcogen.ro/61_AbaszadeRG.pdf)
5. R.G.Abaszade, Analysis of carbon nanotubes, AJP Fizika, Vol.26, №2, section: Az, pp.25-29, 2020.  
[http://www.physics.gov.az/physart/256\\_2020\\_02\\_25\\_az.pdf](http://www.physics.gov.az/physart/256_2020_02_25_az.pdf)

generalized concepts in students based on the methods of intelligent activity and activation of conscious activity, to some extent corresponds to didactic models and is called the sign model of learning. The sign model is also based on the method of learning with KRS and has a deductive structure of learning activities.

Acquisition of knowledge, understanding and principles by solving certain class problems, analysis and classification of specific objects, application of appropriate sign system. It can be concluded that the methodological horizon of the teaching of higher mathematics can be expanded as a result of the application of new information technologies with the help of a system of computer mathematics.

- 6.Kh.M.Popal, R.G.Abaszade, Research and modeling of hybrid energy systems (review), Ecoenergetics, №1, pp.65-69, 2022  
<http://ieeacademy.org/wp-content/uploads/2022/05/ECOENERGETS-JOURNAL-No1.-2022.pdf#page=66>
- 7.R.A.Namazov, R.G.Abaszade, Properties of graphene based solar panels (review), Ecoenergetics, №1, pp.3-8, 2022  
<http://ieeacademy.org/wp-content/uploads/2022/05/ECOENERGETS-JOURNAL-No1.-2022.pdf>
8. E.L.Abdullina, General system requirements for electronic educational materials, New information technologies in university education: Materials of international scientific-methodical conferences: Novosibirsk, March 21-23, pp.114-123, 2000.  
<https://naukaip.ru/wp-content/uploads/2016/12/%D0%9A-112-%D0%A1%D0%B1%D0%BE%D1%80%D0%BD%D0%B8%D0%BA-%D0%BF%D0%BE%D0%B1%D0%B5%D0%B4%D0%B8%D1%82%D0%B5%D0%BB%D0%B5%D0%B9-%D1%8D%D0%BB%D0%B5%D0%BA%D1%82%D1%80%D0%BE%D0%BD%D0%BD%D1%8B%D0%B9.pdf>

9.Yu.Yu.Baranova, Methods of using electronic textbooks in the educational process, Narodnoe obrazovanie, №8, pp.43-47, 2000.

10.A.I.Bashmakov, Development of computer textbooks and educational systems, Questions of Internet education, №10, pp.54-60, 2003.

<http://genderi.org/entrepreneurship-education-in-russia-diagnosis-of-the-problem.html>

11.A.I.Bashmakov, Development of computer textbooks and educational systems, M.: "Philip", 616p., 2003.

<https://kai.ru/documents/1359745/12017704/%D0%A1%D0%B1%D0%BE%D1%80%D0%BD%D0%B8%D0%BA+%D0%90%D0%BD%D0%B3%D0%BB+%D1%8F%D0%B7.pdf/93d4d302-855e-460f-af83-f89f420caa42>

12.V.L.Ivanov, Electronic textbook, Informatics and education, №1, pp.71-81, 2002.

<https://cyberleninka.ru/article/n/osobennosti-vospriyatiya-i-ponimaniya-tsifrovyyh-tekstov-mezhdistsiplinarnyy-vzglyad>

13.S.A.Khristochevsky, Electronic multimedia textbooks and encyclopedias: System and environment, Informatics and education, №2, pp.70-77, 2000.

14.S.A.Khristochevsky, Electronic textbook - current situation, Distance and virtual training: Digest of Russian and foreign presses, №6, pp.58-59, 2002.

15.A.V.Khutorskoy, Modern didactics: textbook for universities, SPb.:Peter, 544p. 2001.

[https://www.academia.edu/37839675/Modern Journal of Language Teaching Methods](https://www.academia.edu/37839675/Modern_Journal_of_Language_Teaching_Methods)

16.O.A.Kapush, I.O.Mazarchuk, L.I.Trishchuk, V.Y.Morozovska, S.D.Boruk, S.I.Budzulyak, D.V.Korbutyak, B.N.Kulchitsky, O.G.Kosinov, R.G.Abaszade, Influence of the nature of the dispersion medium on the optical properties of CdTe nanocrystals during sedimentation deposition, Chernivtsi University Scientific Herald, Chemistry (819), pp.7-11, 2019.

<https://doi.org/10.31861/chem-2019-819-01>

## Analysis of the ecological situation of Boyukshor lake

A.A.Khalilova, H.I.Ahmadzade

*Azerbaijan University of Architecture and Construction, Baku, Azerbaijan,*  
[xelilova.afet@mail.ru](mailto:xelilova.afet@mail.ru) , [hicranaxmed@mail.ru](mailto:hicranaxmed@mail.ru)

**Abstract:** The article examines the ecological condition of Boyukshor Lake, one of the largest lakes in the Absheron Peninsula, the causes of pollution, the impact on the environment, and measures to restore it. As a general result of the research, we can say that, the current condition of Lake Boyukshor is very different from its previous condition, which has been polluted with oil and municipal waste for many years, damaging the aesthetic appearance of the city and, most importantly, causing serious environmental problems, and it is clear that positive results have been achieved. It is also possible to be sure that the ecological condition of the area will improve after the implementation of the planned work for the second phase of the restoration of the lake.

**Keywords:** Absheron lakes, Water resources, Water pollution, Wastewater, Boyukshor Lake.

### 1.Introduction

There are more than 200 natural and artificial lakes in the Absheron Peninsula. Among the natural lakes, Boyukshor, Masazir, Binagadi, Kurdakhani, Khojasan and Red Lake are especially distinguished by their size, depth and total capacity.

Until the 1950s, these lakes were fed mainly by groundwater and atmospheric water. In autumn and winter, the level of the lakes rose to a maximum, and

in spring and summer it fell to a minimum. Some small lakes dried up and turned into ponds and salt marshes. Later, due to the development of oil extraction, oil refining and chemical industries, the amount of man-made wastewater began to increase, which led to a significant increase in the number of water bodies in Absheron [1].

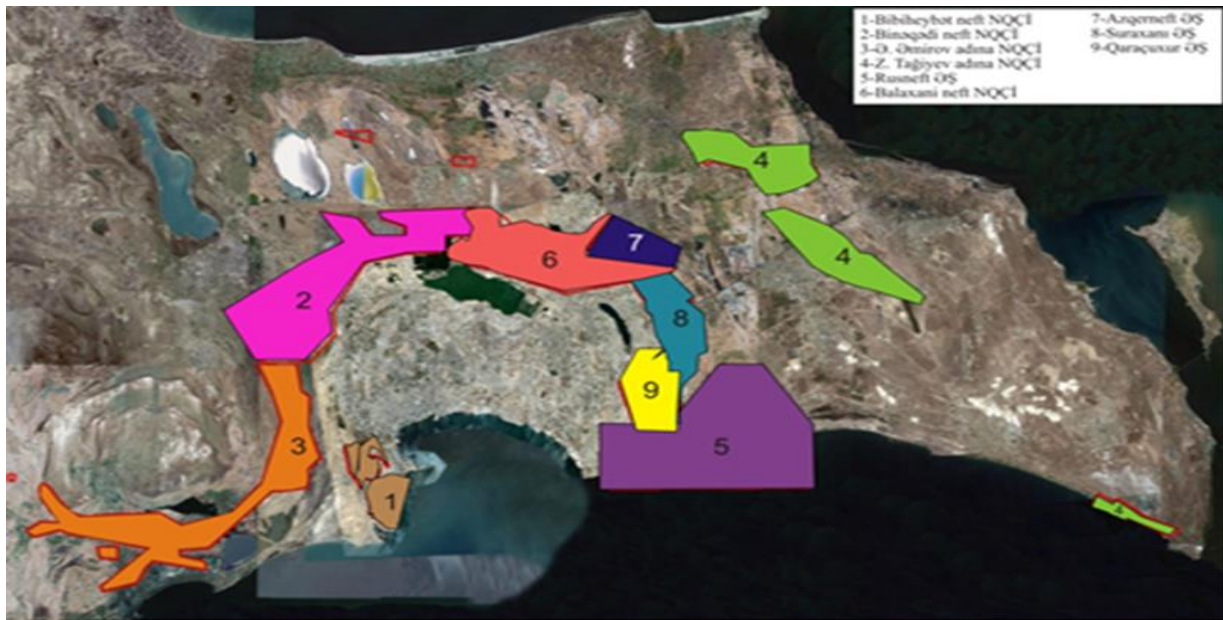

Figure 1. Oil pollution on the Absheron Peninsula GPD [2].

The long-term persistence of anthropogenic pressure on the Absheron Peninsula has turned a significant part of the area into man-made areas, landfills and sewage basins. The main problem caused by oil production without taking into account environmental factors is the degradation of lands. Oil-contaminated areas cover 2,20,000 hectares, while oil industry wastes cover 15,50,000 hectares, and 74.3% of the area covered by industrial wastes. Among the districts around Baku, such polluted areas are 5.20 thousand ha in Garadagh, 3.40 thousand ha in Binagadi, 3.10 thousand ha in Sabunchu, 3 thousand ha in Khazar district, 2.10 thousand ha in Surakhani, as well as 0.70 thousand ha in Sabail district of the city. ha has been. In these areas, oil-soaked soils and ponds with produced water from produced oil wells have been formed [3].

## 2. Experimental details

Boyukshor Lake is the lake with the largest water surface among the Absheron lakes and is in an ecologically tense situation.

According to the data, the average depth in some open areas of the lake is 3.40m - 3.95m, and the maximum depth is 4.20 m. Depth in the coastal parts of the lake varies from 0.5m to 1.7m. The lake is oval in shape and reaches 10.0km in length from north-west to south-east. The maximum width is 1.50 - 2.0km. It is surrounded on the north by a sloping terrace of the ancient Caspian, and on the south by a rectangular slope.

Currently, Boyukshor Lake is a closed basin where

Oil contaminated lands in Absheron make up 11% of the area. The depth of the layer contaminated with oil and oil products reaches about 2.0-2.5 meters. It was observed that the amount of oil products in the soil was up to 26%. In some areas, the depth of pollution and the degree of pollution are expressed in larger numbers.

F.G.Aliyev, H.H.Khalilova and others, they studied the ecological condition of oil-contaminated lands, flooded areas and areas contaminated with industrial wastes in the activity zones of oil production departments on the Absheron Peninsula and applied an atlas reflecting their current condition [2].

Recent scientific advances have increased the application of nanomaterials [6-9].

groundwater flows. The water surface of the lake is 1,300 hectares and its volume is 45 million m<sup>3</sup> (Figure 2).

For many years, Boyukshor Lake was discharged sewage from the sewerage systems, household, trade and other facilities and individual houses of Binagadi, Sabunchu and Narimanov districts of the city. One of the main sources of pollution in the lake was the Balakhani landfill in the eastern part of the lake in the Sabunchu district. Another source of pollution has been the discharge of petroleum water into the lake since the 1930s during oil extraction in the surrounding areas.

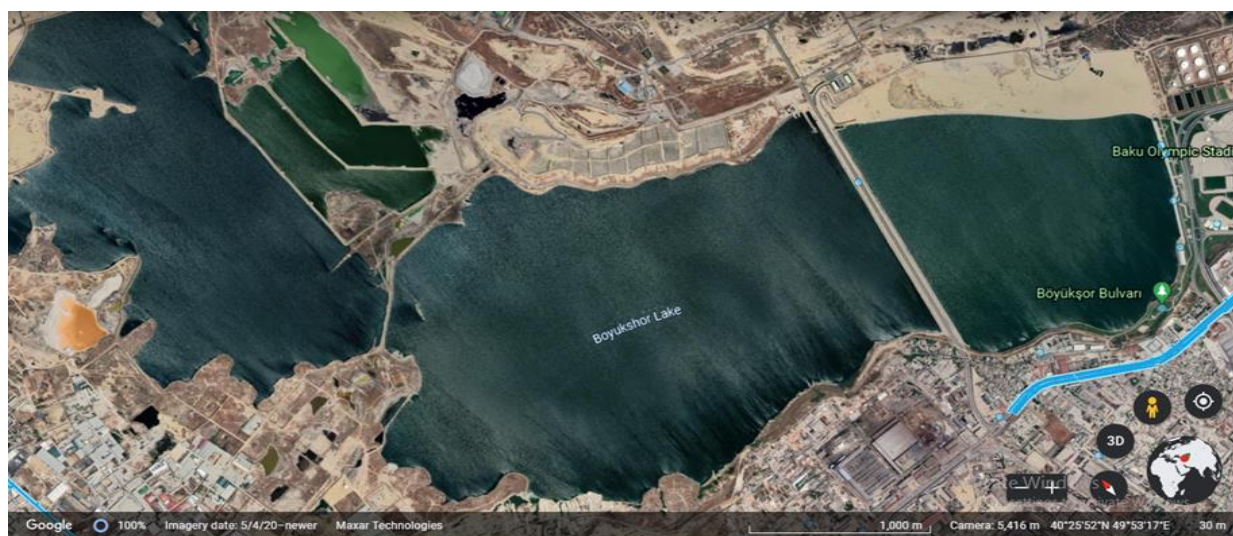

Figure 2. Aerospace view of Boyukshor Lake (2021)

According to statistics, in the 1920s, oil and mineral water was discharged into the lake through the Keshla canal. 60% of this water was drilled, and the rest was used in mines and taken directly from the sea by water lines. Since the 1970s, fecal, domestic and industrial water has been discharged into the lake. These waters were discharged into the lake through open canals in an unsystematic manner without a treatment process. This significantly worsened the ecological and sanitary condition of the area, and the bottom of the lake and the shoreline remained under the bitumen layer of oil products. Due to the evaporation of oil products in hot weather, light fractions of oil are released into the atmosphere, causing a strong odor.

Boyukshor Lake belongs to the group of saline lakes due to its mineral content. It has been observed that the mineralization of its water is many times higher than the allowable concentration. The oxygen regime of the lake has been completely disrupted due to pollution. One of the main reasons for the low content of dissolved oxygen in lake water is the acceleration of biological processes as a result of oxidation of pollutants. As a result, it was determined that the biochemical consumption of oxygen in Lake Boyukshor is several times higher than normal. Thus, the amount of calcium, magnesium and chlorides is several times higher than the sanitary norm, and sulfates are several times higher. Observational data show that the concentrations of petroleum products and phenols, which are the main pollutants of the lake, are many times higher than the MAC. Synthetic detergents in the lake are also above the norm. The amount of heavy metals such as copper, cadmium, iron, zinc and manganese in the lake is several times higher than the main pollutants.

According to the literature, the level of the lake began to rise in 1974, and in 1994 reached its maximum. As a result, the Baku airport highway, surrounding areas, as well as the cemetery were flooded. For this purpose, in order to lower the level of the lake, municipal and other wastewater was collected in a collector and discharged into the Hovsan water canal. According to the degree of pollution of Boyukshor Lake, in 2000 it was classified as a very polluted water class of the quality class, but since 2004 this indicator has been classified as an emergency polluted water class [3].

As a result of many years of primitive incineration of household waste around Baku, smoke and fog surrounding the capital's sky and the Absheron Peninsula, the lack of sufficient infrastructure for

sewage treatment and discharge, and other issues have created a threat of environmental crisis. Therefore, a far-sighted policy had to be introduced to prevent environmental pollution.

The high level of political stability, economic development and international image of Azerbaijan was reflected in the holding of the first European Games in Baku. One of the biggest events in the world in 2015 was these competitions. Residents and guests of the city, who visited the Olympic Stadium, the main sports arena where several sports, opening and closing ceremonies of the Games were held, were amazed by the beauty of the surrounding area in addition to the stadium itself. Beautiful lake, boulevard, park, green areas, sports grounds open to everyone, children's playgrounds, etc. The area of the boulevard was considered an ecological disaster zone only a year ago [4].

The "State Program on socio-economic development of Baku and its settlements in 2014-2016" approved by the Decree signed by President Ilham Aliyev on January 17, 2014 and "Additional measures in the field of improvement, protection and use of the ecological condition of Boyukshor Lake Everything was completely changed in the area with the work carried out in accordance with the Decree dated December 26, 2013. Under the coordination of the Ministry of Economy and Industry, Tamiz Shahar OJSC handed over the first phase of the project in May 2015.

In a short time, Lake Boyukshor and its shores have been transformed from an ecological disaster zone into a recreation area. The result is half of the plan. The project for the complex restoration of Boyukshor Lake consists of two parts. In order to implement the initial stage and isolate the project area, a 1,570-meter-long dam was built in the project area and Lake Boyukshor was divided into two parts. This dam is the foundation of the 8-lane highway connecting Ziya Bunyadov Avenue and Balakhani Highway. In the next phase of the project, it is planned to clean the other side of the lake.

Large amounts of industrial and domestic wastewater and oil residues discharged into Lake Boyukshor since the Soviet era have been prevented. Thus, before the start of the project, industrial and domestic wastewater was discharged into the lake from 76 sources. These sources have been completely eliminated in the project area, and in the remaining area it has been reduced to 20, and this figure is declining. The level of oil pollution in the cleaned areas of the bottom of the lake has dropped from



121,000mg/kg to 86, which means that the bottom of the lake is already within environmental standards.

A sewer line has been laid along the south coast of the project area, and sources of pollution in this area have been completely prevented. Preventing all sources of discharge into the lake improves water quality. The main oil-contaminated area is on the side of Balakhani settlement of the project area. In order to prevent oil spills from the ancient Balakhani oil fields polluting this part of the lake, a 1,850 meter-long dam was built by the Balakhani settlement along the historical course of the lake. At the same time, work is underway to remove and neutralize the dirty sediments that have accumulated at the bottom of the lake for more than a hundred years. In the initial phase of the project, 2.8 million m<sup>3</sup> of sediment was removed from the bottom of the lake and collected in a temporarily isolated storage area for future disposal. Serious protection work has been organized, including the protection zone of the lake, and the pollution of the lake and shoreline with household and construction waste has been completely prevented.

Construction work on the first stage of the lake has been completed. A boulevard and a park have been built on the east and south shores of the project area. The total area of landscaping is more than 15

hectares. Oil-contaminated lands in this area have been cleared. Also, on the eastern shore of the lake, groundwater contaminated with metal plates was completely prevented from entering the lake and a drainage system was installed.

The length of the coastal walkway is 2.50 kilometers. Sports and children's playgrounds have been built here, separate running and bicycle lanes have been laid, bicycles have been provided, and about 80,000 trees and ornamental shrubs have been planted. The complex of fountains installed inside the lake not only pleases the guests of our city, but also enriches it with oxygen to improve the quality of the lake's water. As a result, all conditions have been created here for the residents and guests of the capital to relax. Special solar-powered devices are used to manage the lake, improve water quality and monitor it.

In the next stage, which envisages the full restoration of Boyukshor Lake, the lake will be returned to its natural historical course, the water level will be regulated and the ecosystem will be restored [5].

Specialists created a geo-database of the project area, collected and georeferenced relevant maps of the project area, and conducted geospatial analysis.

At the same time, the following digital models and maps have been developed:

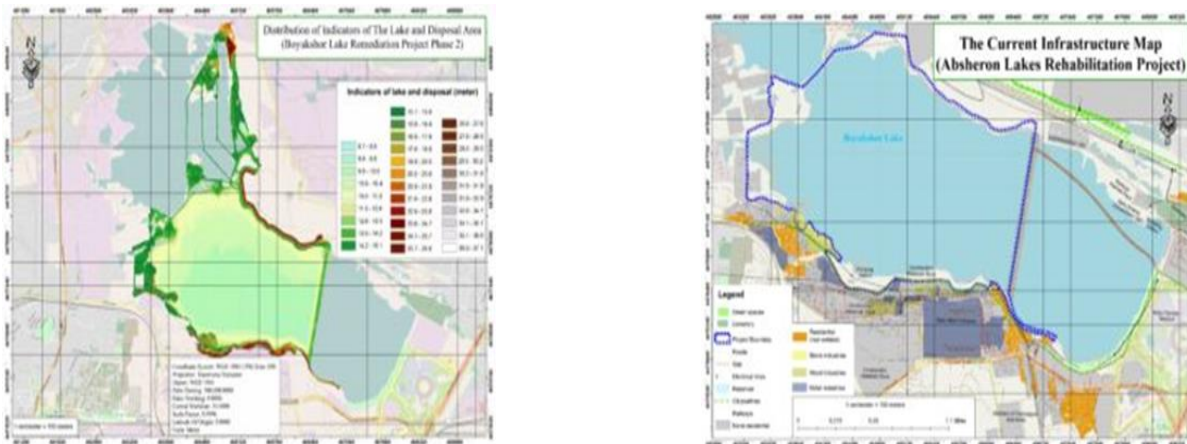

Figure 3. Planned works for Phase II.

### 3. Conclusions

As a general result of the research, we can note that the current condition of Boyukshor Lake is very different from its previous condition, which has been polluted with oil and municipal waste for many years, damaging the aesthetic appearance of the city and,

most importantly, causing serious environmental problems. clearly visible. It is also possible to be sure that the ecological condition of the area will further improve after the implementation of the planned work on the restoration of the lake for the second stage.

## References

- 1.F.G.Aliyev, A.B.Badalov, E.M.Huseynov, F.F.Aliyev, Ecology, Textbook. Baku, Science, 828 p., 2012,
- 2.F.G.Aliyev etc all., Atlas compiled on the basis of a managed electronic database of oil-contaminated lands, flooded areas and other areas contaminated with industrial wastes in the activity zones of oil production departments on the Absheron Peninsula, Baku, 225 p., 2009.
- 3.A.A.Khalilova, S.F.Mehdiyeva, S.Y. Maharramova, Ecological condition of polluted lakes in Absheron peninsula and measures for their restoration, Journal of Ecology and Water Management, №2, Baku, pp. 25-29, 2018.
- 4.I.R.Rashidova, The second boulevard of Baku, Kaspi newspaper, Baku, 13 p., 2015.
- 5.Clean City/Projects/Ecological restoration project of Absheron lakes”.  
<https://tamizshahar.az/en/layiheler/4>
- 6.R.G.Abaszade, S.A.Mamedova, F.H.Agayev, S.I.Budzulyak, O.A.Kapush, M.A.Mamedova, A.M.Nabiyev, V.O.Kotsyubynsky, Synthesis and Characterization of Graphene Oxide Flakes for Transparent Thin Films, Physics and Chemistry of Solid State, Vol.22, №.3, pp.595-601, 2021.  
[DOI: 10.15330/pcss.22.3.595-601](https://doi.org/10.15330/pcss.22.3.595-601)
- 7.S.R.Figarova, E.M.Aliyev, R.G.Abaszade, R.I.Alekberov, V.R.Figarov, Negative Differential Resistance of Graphene Oxide/Sulphur Compound, Journal of Nano Research Submitted, Vol.67, pp.25-31, 2021.  
<http://dx.doi.org/10.4028/www.scientific.net/JNanoR.67.25>
- 8.R.A.Namazov, R.G.Abaszade, Properties of graphene based solar panels (review), Ecoenergetics, №1, pp.3-8, 2022.  
<http://ieeacademy.org/wp-content/uploads/2022/05/ECOENERGETS-JOURNAL-No1.-2022.pdf>
- 9.Kh.M.Popal, R.G.Abaszade, Research and modeling of hybrid energy systems (review), Ecoenergetics, №1, pp.65-69, 2022.  
<http://ieeacademy.org/wp-content/uploads/2022/05/ECOENERGETS-JOURNAL-No1.-2022.pdf#page=66>

## **About some technical safety and environmental problems of sarsang water reservoir**

**M.I.Maharramov**

*Azerbaijan University of Architecture and Construction, Baku, Azerbaijan,  
[maharramovmobil@gmail.com](mailto:maharramovmobil@gmail.com)*

**Abstract:** Studies on the technical safety and ecological problems of Sarsang water reservoir have been carried out and their consequences have been shown in the results of special calculations. Since these problems cause discussions in the world political arena, some references have been given about the development of measures to eliminate them.

**Keywords:** Water reservoir, Mathematical models, Hydroelectric power station.

### **1.Introduction**

The development of filtration systems with the help of nanomaterials, which are considered the latest achievements of modern science, remains relevant [1-7]. Sarsang water reservoir located in Azerbaijan Republic on the territory of Agdara region was built on Tartar River in 1976. The total volume of the reservoir is 560 million m<sup>3</sup>, the useful volume is 500 million m<sup>3</sup>, and the dead volume is 60 million m<sup>3</sup>. The normal filling level of the reservoir is 726 m, the maximum filling level when flood waters flow is 728,5m, the level of dead volume is 662m, the length of the reservoir at normal filling level is 11,75km, width is 1,75km, the normal water depth is 103m. The area of the water mirror at the Normal level is 1346ha, and the area of the water mirror at the level

of dead volume is 270ha. The length of the coastline is 50,25km. The height of the dam is 125m, the length is 555,1m, and the width from the top is 10,2m. There is also a hydroelectric power station (HPS) consisting of 50 turbines each with a capacity of 2 Mvt. Each turbine has a water discharge capacity of 30m<sup>3</sup>/sec and only 60m<sup>3</sup> of water can be released from HPS. In addition, 6 valves have been installed in the dam in cases where HPS did not work to supply water to the river for irrigation purposes. Each of these valves is 5m<sup>3</sup>/sec and only 30m<sup>3</sup>/sec of water can be supplied to the Terter River. As well as in cases when the reservoir is full, flood waters in the amount of 740m<sup>3</sup>/sec are intended to flow into Terter river through emergency watershed [8-10].

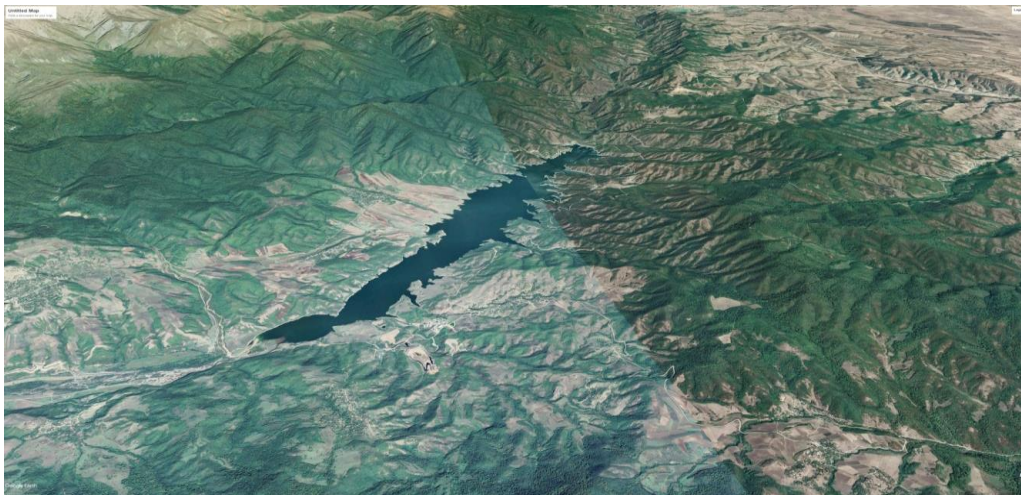

*Figure 1. Sarsang reservoir*

## **2. Experimental details**

It should be noted that Sarsang is one of the highest water reservoirs in the Azerbaijan Republic due to the height of the dam. As we said its height is 125 meters. Before the armenian occupation Sarsang reservoir provided 100 thousand hectares of land in 6 regions of the Republic (Tartar, Aghdam, Barda, Goranboy, Yevlakh and Aghjabadi) with irrigation water. The lack of irrigation water to agricultural crops as a result of the inability to use water of the reservoir after the occupation of the territories has caused irreparable damage to this region of the Republic [8-10].

At present, it is assumed that the water reservoir is not satisfactory in terms of technical safety and ecology, since complex maintenance of the warehouse and its facilities has not been provided for a long time. Since Sarsang water reservoir was located in the occupied area before the Patriotic War II, the collapse of its dam as a result of accident or provocation poses a serious threat to the settlements located below the reservoir.

In this regard, in order to assess the damage that an emergency may cause to the population and territory and to prepare a graphical model, the Ministry of Emergency Situations of Azerbaijan Republic [11] together with one of the foreign companies conducted investigations and certain results were obtained. During the investigation, consultations were held with Turkish specialists in the State Water Affairs Department of Turkey and "Suyapi" company, mathematical models used by them were applied during water accident. For information, we note that the calculations are developed in a special hydrological program and the accuracy of the results is 60-70% . We consider that in order to more accurately calculate the results after the second Patriotic War, a thorough examination of the territory should be carried out, a topographic map of the reservoir should be drawn up, large-scale environmental studies should be carried out, bathimetric measurements should be made in the lake,

## **3. Conclusions**

Sarsang water reservoir has serious environmental and technical safety problems. They must be resolved

## **References**

I.R.G.Abaszade, S.A.Mamedova, F.H.Agayev, S.I.Budzulyak, O.A.Kapush, M.A.Mamedova, A.M.Nabiyev, V.O.Kotsyubynsky, Synthesis and Characterization of Graphene Oxide Flakes for

hydrological studies should be carried out, water flow rate should be studied, work must be done. of the pits should be calculated, etc. work must be done.

The results obtained show that during the collapse of the dam, the territory at a distance of about 48km below the dam and all residential facilities located in that area are included in the risk zone. In the calculations it was concluded that 80% of the water discharge of the lake during the incident and the distance from the dam to the 48th km will reach the end point with 20% loss. Here, the volume of water retention and soil water absorption of pits in the water body is included in the above-mentioned 20% loss. The materials obtained from the 1:50 000 scale topoplanes and the GeoEye space satellite of the Republic of Azerbaijan were used in the design of cartographic materials.

The speed of water at the moment of the collapse of the dam can reach 100-200 km/h, depending on the level of the lake. The speed in the flow rate of water varies depending on the relief of the area where the water flows. For this reason, starting from the dam, the time of water flow to the last point where the water can go is estimated.

As a result of the collapse of the dam, both longitudinal profile sections (indicating the relief where the water flows and the height of the water) and transverse profile sections (26 cuts on the most shallow areas where water can fill) were drawn from the reservoir in the river Terter, and later in the direction of water distribution (with destructive force) on relatively At the same time, the area of the flooded area is indicated on the map by calculation

Also, the height of the water level in any cut during the flow of water, as well as the width of the pipe, was calculated. It has been established that during the collapse the water can rise from the dam at an altitude of 65 m (taking into account the level of dead water in the lake). Depending on the relief (in lowland areas), the water can rise up to 48-60 meters in the stream direction of the Terter river.

quickly. To do this, first of all, this water reservoir must be fully controlled by Azerbaijan.

Transparent Thin Films, Physics and Chemistry of Solid State, Vol.22, №3, pp.595-601, 2021.

[DOI: 10.15330/pcss.22.3.595-601](https://doi.org/10.15330/pcss.22.3.595-601)

2.S.R.Figarova, E.M.Aliyev, R.G.Abaszade, R.I.Alekberov, V.R.Figarov, Negative Differential Resistance of Graphene Oxide/Sulphur Compound, Journal of Nano Research Submitted, Vol.67, pp. 25-31, 2021.

<http://dx.doi.org/10.4028/www.scientific.net/JNanoR.67.25>

3.R.G.Abaszade, O.A.Kapush, S.A.Mamedova, A.M.Nabiyev, S.Z.Melikova, S.I.Budzulyak, Gadolinium doping influence on the properties of carbon nanotubes, Physics and Chemistry of Solid State, Vol.21, №3, pp.404-408, 2020.

<https://doi.org/10.15330/pcss.21.3.404-408>

4.R.G.Abaszade, O.A.Kapush, A.M.Nabiyev, Properties of carbon nanotubes doped with gadolinium, Journal of Optoelectronic and Biomedical Materials, Vol.12, № 3, pp.61–65, 2020.

[https://www.chalcogen.ro/61\\_AbaszadeRG.pdf](https://www.chalcogen.ro/61_AbaszadeRG.pdf)

5.R.G.Abaszade, Analysis of carbon nanotubes, AJP Fizika, Vol.26, №2, section: Az, pp.25-29, 2020.

[http://www.physics.gov.az/physart/256\\_2020\\_02\\_25\\_az.pdf](http://www.physics.gov.az/physart/256_2020_02_25_az.pdf)

6.Kh.M.Popal, R.G.Abaszade, Research and modeling of hybrid energy systems (review), Ecoenergetics, №1, pp.65-69, 2022

<http://ieeacademy.org/wp-content/uploads/2022/05/ECOENERGETS-JOURNAL-No1.-2022.pdf#page=66>

7.R.A.Namazov, R.G.Abaszade, Properties of graphene based solar panels (review), Ecoenergetics, №1, pp.3-8, 2022

<http://ieeacademy.org/wp-content/uploads/2022/05/ECOENERGETS-JOURNAL-No1.-2022.pdf>

8.F.A.Imanov, A.B.Alakbarov. Modern changes and integrated management of water resources of Azerbaijan. Baku - Translator - 2017, p.353.

<http://www.sukanal.az/wp-content/uploads/2017/03/F.Imanov-A.Alekberov.pdf>

9.Z.S.Musayev, K.M.Mammadov, T.M.Mahmudov., F.M.Ismayilov, M.S.Zarbaliyev, Hydrotechnical installations, (III edition), Baku, Education, NPM, 686 p., 2009.

10.E.A.Mammadova. Water supply and reclamation hydrogeology. Textbook for universities. Baku, 229 p., 2003.

[http://anl.az/el/m/me\\_stmh.pdf](http://anl.az/el/m/me_stmh.pdf)

11.Sh.Y.Goychayli, T.A.Ismayilov, Economic and ecological bases of nature use, Baku, 232 p., 2009.

## Fuzzy identification of main characteristics of gas lift wells

A.Y.Aliyev

*Azerbaijan State Oil and Industry University, Baku, Azerbaijan,*  
[aliyevamil59@gmail.com](mailto:aliyevamil59@gmail.com)

**Abstract:** This article examines the approach to applying fuzzy definition to predict the gas lift characteristics of an oil well and the optimization of production in formation. The method of obtaining the main characteristic through Prosper software is used. Discusses the determination of maximum oil production and optimal gas consumption. The dependence of the oil produced by the software on the injected gas is obtained graphically. According to the simulation results, modes are determined according to the performance of the gas elevator shaft. Therefore, the article shows how fuzzy sets and correlation function application can be used to generate fuzzy rules for estimating the velocity of injected gas as an important parameter in determining well efficiency.

**Keywords:** Gas lift, Oil wells, Optimization, Main characteristics, Productivity, Fuzzy identification, Membership function.

### 1.Introduction

Gas lift is a form of artificial extraction of oil. In this process, the lift gas is first compressed and then injected into the production pipe through the pipeline ring, and when this lift gas enters the production pipe, the oil rises to the surface due to expansion. Figure 1 shows a typical diagram of a gas lift oil well. In this method, the gas is transferred to the ring through a surface gas injection choke and then injected into the pipe to be mixed with a liquid reservoir. This reduces the density of the oil column in the pipes and makes it lighter, thus increasing the rate of extraction from the low-pressure layer.

Gas lift technology is used in most oil fields, as the gas lift method is highly recommended for curved wells, sandy oil and gaseous oil wells. One of the important advantages of the gas lift system is the low operating costs when the injected gas is near the oil field. The application of new technologies for better use of oil resources is being studied. Due to the high instability of production in oil wells, the study of fuzzy identification and stabilization in gas lift wells has become the subject of research.

The principles of gas lift optimization have been developed by establishing a link between the most efficient injection point, gas injection pressure, gas injection rate and production rate from a specific well. These relationships have led to the development of technical procedures, applications and standards for gas lift design methods. However, these design methods need to be optimized and developed to

maximize oil production and to address instability problems in gas lift systems, especially for future research in gas lift design performance. Optimization of gas lift systems is very important to achieve the optimal oil velocity that can be achieved with a certain amount of gas injected into the system.

The purpose of the gas lift is to deliver the fluid to the wellhead, while keeping the bottom well pressure low enough to ensure a high pressure drop between the formation and the bottom well. The reduction in well pressure at the bottom due to gas injection will normally increase the rate of oil production, as gas injection lightens the oil column, so there is more oil flow along the pipeline. However, injecting large amounts of gas increases the bottomhole pressure, which reduces oil production. This is due to the high gas injection velocity causing the slide, where the gas phase moves faster than the liquid and leaves the liquid phase behind. In this case, less liquid will flow along the pipes. Thus, there must be an optimal gas injection rate. Improving the design of gas lift valves to achieve optimal overall oil production rates from the existing gas lift system is a major concern for many oil companies with low investment costs to increase oil production and increase profits. Optimization can be obtained from the collection of data from gas-lifted wells, including design, well test data, well schemes and pressure surveys. Optimization of gas lift system aims to achieve maximum oil production, profit and production under

certain operating conditions [1-6]. Smart materials have a significant impact on increasing productivity

in the oil industry [7-9].

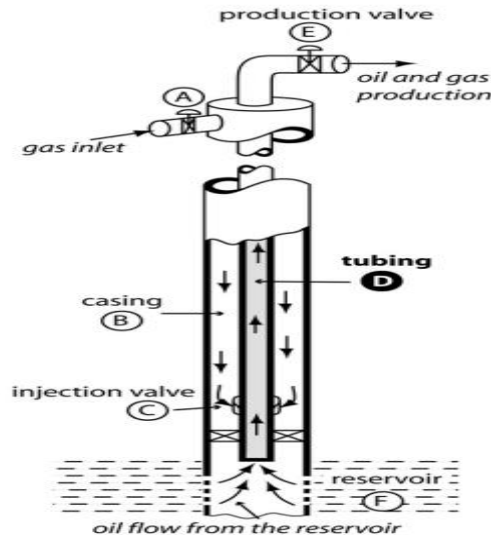

Fig. 1. Gas lift well

The specific consumption parameter is determined by the ratio of production to the amount of gas injected (Fig.1). The lowest value of this parameter determines the optimal mode. The regime with the most oil is called the maximum regime. The operation of the well in the area between these two regimes is expedient, and this area is called the normal working regime. It is not advisable to operate the well outside these regimes.

- R - Special spending
- V - Lift gas injection rate
- Q - Oil production rate
- $P_{min}$  - Optimal mode
- $Q_{max}$  - Maximum mode

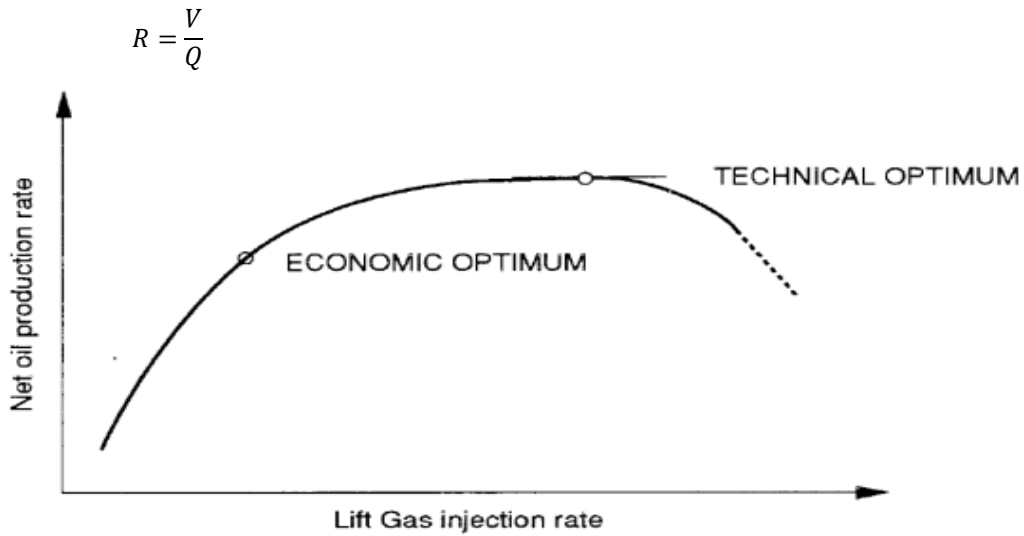

Fig. 2. Gas-lift well performance curve

## 2. Experimental details

The graph of oil production dependence on injection gas is important for gaslift optimization. The gas lift productivity curve describes the reaction of oil production to increasing injection gas volumes. The PROSPER model developed for well A was used as a sample model to determine the optimal gas injection rate for a gas lift well. At the same time, the developed PROSPER model is used to study the impact of other important parameters on successful gaslift operation. Basic well data was used to create the PROSPER model. Then the model was adapted to real data, correlations were selected (Fig 3). The

purpose of studying the effects of factors such as wellhead pressure, injection gas composition, pipe protrusions and water cut-offs on well production is to determine their impact on well production. Factors influencing production should be optimized and taken into account in the future development of the industry. Minimal impact factors may not be considered in the optimization process to save more time and effort.

In the case of fuzzy identification of a gas lift well, the membership functions are determined for certain points on the main characteristic graph (Fig 4, Fig 5).

## 3. Conclusions

What is important is the formation of a fuzzy set of optimal and maximal regimes and the establishment of membership functions. Thus, it is determined by

fuzzy logic to what extent the gas lift well is operated with optimal or maximum productivity in the actual operating mode

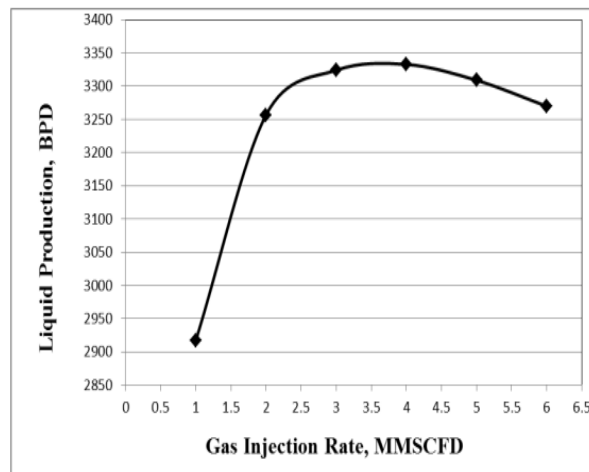

Fig 3.. Basic characteristics of well A.

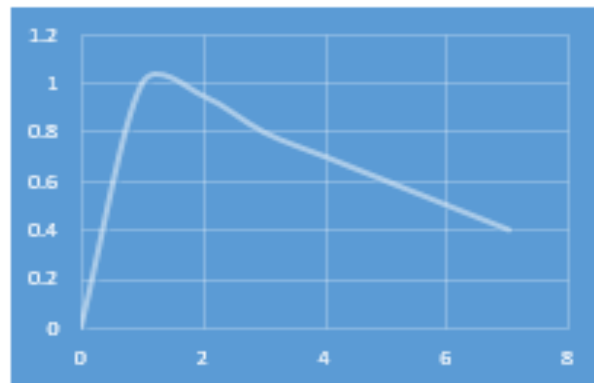

Fig 4. Membership function of Optimum mode in Excel program.



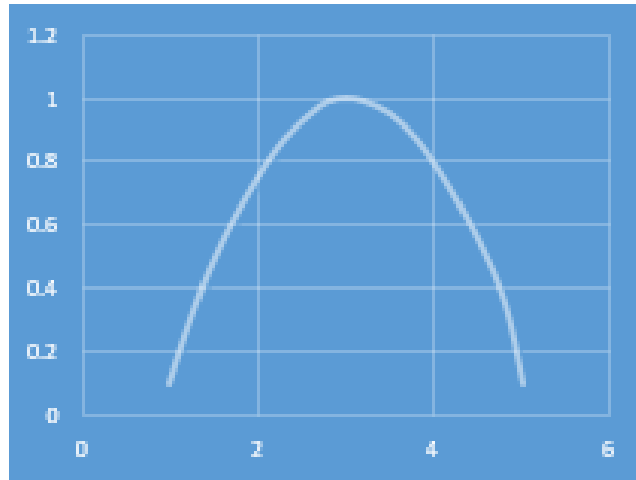

Fig 5. Membership function of Maximal mode in Excel program

### References

- 1.A.Sh.Shedid, S.Y. Mostafa, Simulation Study of Technical and Feasible Gas Lift Performance. ISSN 0973-6328, Vol.10, №1, pp.21-44, 2016.  
[https://www.researchgate.net/publication/308062978\\_Simulation\\_Study\\_of\\_Technical\\_and\\_Feasible\\_Gas\\_Lift\\_Performance](https://www.researchgate.net/publication/308062978_Simulation_Study_of_Technical_and_Feasible_Gas_Lift_Performance)
- 2.E.Jahanshahi, K.Salahshoor, Y.Sahraie, Fuzzy Estimation And Stabilization In Gas Lift Wells Based On A New Stability Map. Vol.1, pp.1937-7991, 2016.  
[https://www.researchgate.net/publication/289562997\\_Fuzzy\\_estimation\\_and\\_stabilization\\_in\\_gas\\_lift\\_wells\\_based\\_on\\_a\\_new\\_stability\\_map](https://www.researchgate.net/publication/289562997_Fuzzy_estimation_and_stabilization_in_gas_lift_wells_based_on_a_new_stability_map)
- 3.A.B.Jahanzeb, Optimization Of Gas Lift System, 2014.  
<https://utpedia.utp.edu.my/13962/1/jahanzeb%20bugti%20thesis%28Last%20Version%29.pdf>
- 4.M.O.Khalid Elmabrok Gas Lift Optimization And Flow Instability, 2017.  
<https://usir.salford.ac.uk/id/eprint/43734/3/Thesis%20Elmabrok.pdf>
- 5.M.Khalilzadeha, H.Shakerib, Sh.Zohrehvandi, Risk identification and assessment with the fuzzy DEMATEL-ANP method in oil and gas projects under uncertainty.  
[https://www.researchgate.net/publication/349525757\\_Risk\\_identification\\_and\\_assessment\\_with\\_the\\_fuzzy\\_DEMATEL-](https://www.researchgate.net/publication/349525757_Risk_identification_and_assessment_with_the_fuzzy_DEMATEL-ANP_method_in_oil_and_gas_projects_under_uncertainty)
- [ANP method in oil and gas projects under uncertainty](#)
- 6.T.O.Odedele, H.D.Ibrahim, Predicting Oil Well Gas Lift Performance and Production Optimization Using hybrid Particle Swarm Optimization and Fuzzy Support Vector Machines. ISSN: 2078-0966.  
[http://www.iaeng.org/publication/WCE2016/WCE2016\\_pp110-116.pdf](http://www.iaeng.org/publication/WCE2016/WCE2016_pp110-116.pdf)
- 7.S.R.Figarova, E.M.Aliyev, R.G.Abaszade, R.I.Alekberov, V.R.Figarov, Negative Differential Resistance of Graphene Oxide/Sulphur Compound, Journal of Nano Research Submitted, Vol.67, pp.25-31, 2021.  
<http://dx.doi.org/10.4028/www.scientific.net/JNanoR.67.25>
- 8.R.G.Abaszade, O.A.Kapush, S.A.Mamedova, A.M.Nabiyev, S.Z.Melikova, S.I.Budzulyak, Gadolinium doping influence on the properties of carbon nanotubes, Physics and Chemistry of Solid State, Vol.21, №3, pp. 404-408, 2020.  
<https://doi.org/10.15330/pcss.21.3.404-408>
- 9.R.G.Abaszade, O.A.Kapush, A.M.Nabiyev, Properties of carbon nanotubes doped with gadolinium, Journal of Optoelectronic and Biomedical Materials, Vol.12, №3, pp.61-65, 2020.  
[https://www.chalcogen.ro/61\\_AbaszadeRG.pdf](https://www.chalcogen.ro/61_AbaszadeRG.pdf)

## **History of hybrid cars**

**F.G.Aliyev, N.Q.Yusifli**

*Azerbaijan University of Architecture and Construction, Baku, Azerbaijan,  
[info@ieeacademy.org](mailto:info@ieeacademy.org), [nigarr2017@mail.ru](mailto:nigarr2017@mail.ru)*

**Abstract:** The human race has always been inclined to search, innovation, and creation. From the beginning of the 19th century, measures were taken to create the first car engines. The cars created at that time were powered by electricity and had a device that was manually turned on to start and gave the initial impulse. In 1899, the first hybrid car was invented. Hybrid cars are defined as any car that runs on two energy sources. The most common hybrid powertrain combines a gasoline engine with an electric motor. The article discusses the history of hybrid cars from the past to the present.

**Keywords:** Hybrid cars, Electric cars, Petrol cars, Car history, Demand for hybrid cars.

### **1.Introduction**

The history of hybrid cars goes back more than 100 years. Hybrid cars are defined as any car that runs on two energy sources. The most common hybrid powertrain combines a gasoline engine with an electric motor. These cars are known as hybrid electric cars. Although hybrids seem to be a new phenomenon, the technology has been around since the advent of the car. In fact, car manufacturers have been developing and building hybrids since the beginning of the automotive industry.

The first electric car model was developed in 1835 in the Netherlands by Professor Stratingh. Then, in 1838, Robert Davidson developed an electric locomotive that could reach speeds of 6.4km/h. Lead-acid batteries were developed after 1859 and began to be used in electric vehicles [2].

Before the development of the internal combustion engine, electric cars had many records in terms of speed and distance. One of the most important was the breaking of the record of 100km/h on April 29, 1899. Although Thomas Davenport was one of the first to install an electric motor in a car, the electric car in the traditional sense was not developed until 1891 [3].

Due to technical limitations, the maximum speed of these first electric cars was about 32km/h. Despite its relatively low speed in the early 1900s, electric cars had a number of competitive advantages. They did not emit any vibrations, odors or sounds related to petrol cars. Replacing gears in gasoline-powered cars was the most difficult part of driving, and electric cars did not require gear changes. Electric cars were

popular only among wealthy customers who used urban transport, so their limited range was not relevant. Electric cars also had the advantage, as no manual effort was required to start driving. The front of the petrol cars had handles to start the engine, which required starting power. Electric cars were often sold as a suitable vehicle for female drivers because they were easier to operate. Early electric cars were even labeled "women's cars" [4].

In 1882, Siemens produced the world's first electric trolleybus, the Electromote, in Berlin. This car had two 2.2kW engines, powered by 550V DC and an average speed of 12km/h.

In 1886, Carl Benz produced and marketed the Motorwagen, the first car to run on an internal combustion engine. The car had three wheels and the engine was in the back and under the passengers. The car with an internal combustion engine could reach a maximum speed of 16km/h with a power of 0.55kW.

In 1895, Morris and Salomon Electrobats created a two-seater electric car. In England, in 1897, the London Electric Taxi Company launched 15 electric taxis. In 1901, the New York Taxi Company began using electric cars as taxis.

In 1900, the French Electric car and in 1903 the Krieger electric gasoline cars were produced, and the hybrid configuration model was tested for the first time. Ferdinand Porsche designed the first experimental hybrid electric car during this period and named it the Mixt Wagen. Lead-acid batteries are used in the car by placing electric motors on each wheel of a car with an internal combustion engine as

a direct-driven hub motor. The car could accelerate to 60km/h.

At the turn of the century, 40 percent of American cars ran on steam, 38 percent on electricity, and 22 percent on gasoline. Most of the first electric cars had extravagantly designed carriages with luxurious interiors filled with massive and expensive materials. These cars are designed for the upper class of very wealthy customers who are distinguished by owning such a car. The basic models of electric cars cost about \$ 1,000 (about \$ 28,000 today) and an average of about \$ 3,000 (about \$ 84,000 today). Sales of electric cars peaked in 1912.

In 1916, the Woods Motor Vehicle Company produced a hybrid electric car. The parallel hybrid electric car model is designed by connecting the four-cylinder gasoline engine in the car directly to the electric motor / generator set, and then to the front transmission axle via a conventional thrust shaft. From the early 1920s to the 1960s, almost all electric car manufacturers continued to use internal combustion engines. Although interest in electric cars declined between the 1920s and 1960s, cars with internal combustion engines were the focus of attention around the world. The main reasons for the decline in interest in electric cars were:

- Improving the physical condition of intercity roads in the United States has created a need for longer distances,
- Falling gasoline prices with the discovery of crude oil in Texas,

- Charles Kettering's invention of the starting engine in 1912. As a result, there is no need to turn the crank manually to start the engine first.

- Mass production of Henry Ford vehicles with internal combustion engines and reduced vehicle costs. In 1912, the selling price of electric cars was about \$ 1,750, and gasoline-powered cars were around \$ 650 [5].

Electric cars could not create a competitive environment due to the above situations. In 1935, there were almost no electric cars on the market, and development research was not conducted until the 1960s.

Over time, emissions from internal combustion engines have been found to cause air pollution, and some small manufacturers have begun to produce electric cars to prevent air pollution. Thus, in the 1960's, interest in electric cars began to rise again. The oil crisis of the mid-1970s also led many countries, including the United States, Britain, Germany, France, Italy, and Japan, to accelerate research into electric vehicles. In the 1980s, governments began to increase interest in electric cars because they were not environmentally friendly, and to provide economic support from official sources. After 1990, with the development of new battery technologies, many car companies began to develop electric car models such as Ford-Think City, Nissan-Altra EV and Peugeot 106-Electric [2, p.3]. Some of these cars and their characteristics are given in Table 1.

**Table 1. Full electric cars and features**

Producer	Citroen	Daihatsu	Ford	GM	GM	Honda	Nissan	Nissan	Peugeot	Renault
1	2	3	4	5	6	7	8	9	10	11
Model name	AX/Saxo Electrique	Hijet EV	Think City	EV1	EV1	EV Plus	Hypermini	Altra EV	106 Electric	Clio Electric
Driver type	Direct current motor	SM synchronous	3-phase asynchronous	3 fazalı asinxron	3 fazalı asinxron	SM synchronous	SM synchronous	SM synchronous	Direct current motor	AC asynchronous
Battery type	NiCd (nickel-cadmium battery)		NiCd (nickel-cadmium battery)	Pb-turşusu (qurğuşu n-turşu batareyası)	NiMh (Nickel-metal hydride battery)	NiMh (Nickel-metal hydride battery)	Li-ion (lithium-ion battery)	Li-ion (lithium-ion battery)	NiCd (nickel-cadmium battery)	NiCd (nickel-cadmium battery)
Power (kW)	20		27	102	102	49	24	62	20	22
Tension (V)	120		114	312	343	288		345	120	114
Battery capacity	12		11,5	16,2	26,4		15	32	12	11,4
Power charging connector			Conductor	Inductive	Inductive	Conductor	Conductor	Conductor		Conductor

Producer	Citroen	Daihatsu	Ford	GM	GM	Honda	Nissan	Nissan	Peugeot	Renault
1	2	3	4	5	6	7	8	9	10	11
Speed (km/saat)	91	100	90	129	129	129	100	120	90	95
Distance (km)	80	100	85	95	130	190	115	190	150	80
Charging times (saat)	7	7	5-8	6	6	6-8	4	5	7-8	
Selling price (\$)		23990					36000		27000	27400

Hybrid electric cars are formed using many and different energy sources. Accordingly, there are hybrid electric car versions such as battery-fuel cell, battery-condenser or battery-battery. Many hybrid electric vehicles use an internal combustion engine, stirling engine, gas turbine or electrochemical battery as the power source.

Hybrid cars are generally grouped under three main headings: serial hybrid, parallel hybrid, and serial/parallel hybrid. The general difference between hybrid cars is the degree to which the power required for the car's movement is provided by an electric motor. The energy conversion system for a hybrid electric vehicle includes an energy storage system, a power unit and the vehicle's propulsion systems. The main elements of energy storage are batteries, supercapacitors and flywheels. Otto engines, diesel engines, gas turbines and fuel cells are widely used as hybrid power plants. The hybrid power can be provided by an electric motor as in the series hybrid model or by an internal combustion engine in addition to the electric motor as in the parallel hybrid model. The advantages of hybrid electric cars are given below:

- Energy loss is minimized with advanced regenerative braking techniques. Thus, when the car slows down or stops, the energy used is recovered and recharges the batteries.
- Due to the small size of the internal combustion engines used, the engine weight is reduced.
- Increases fuel efficiency.
- Emission values are significantly reduced.
- As alternative fuels can be used as fuel in hybrid electric vehicles, dependence on residual fuels is reduced.

### 3. Conclusions

This article gives a brief overview of the history of hybrid machines. Today, the excessive number of cars and the fact that most of these cars run on gasoline or diesel fuel have led to significant pollution of the air

-Hybrid electric cars do not make engine noise when the car is stopped because the internal combustion engine does not work.

-Operating losses in idle state are very small [2]. One of the latest achievements of science is increasing the opportunities for the study and application of graphene-based nanomaterials [6-11].

### 2. Experimental details

Electric motor, battery technology, power transmission systems, power electronics and control systems, etc. Demand for electric vehicles is expected to increase worldwide as developments in areas such as It is clear that the widespread use of electric vehicles will not only reduce the amount of harmful gases emitted into the environment, but also lead to positive improvements in the quality of the environment and reduce dependence on depleted and expensive energy resources such as oil.

Purchase prices for electric vehicles are expected to remain high in the next few years, vehicle models will be limited and batteries will be as low as 160 km (for fully electric vehicles). In this context, attention should be paid to the weight and charging time of the battery. The high investment costs of private battery charging stations to be installed in homes or workplaces may limit access to electric vehicles. Necessary infrastructure preparations and network security measures will be taken in the supply of electricity and the number of charging stations to be installed in public places will be increased, legal regulations, discounts and tax exemptions / freedoms will be implemented.

and the environment. Thus, the issue of creating and using hybrid machines has become relevant again. The recent increase in interest in hybrid cars has prompted us to write an article on the subject.

Considering that the topic of "History of Hybrid Cars" is not widely involved in scientific research in our country, we can say that both the object of

research and the topics discussed in the article are its scientific novelty.

## References

1. <https://www.lemo-project.eu/wp-content/uploads/2015/01/History-of-electric-cars.pdf>
2. K.Alper, Advances in Electric Vehicle Technology and Future Expectations, Mehmet Akif Ersoy University Institute of Science Journal 5 (1), p.1-13, 2014.
3. N.Ünlü, Ş.Karahan, O.Tür, H.Uçarol, and others, Electric Tools, TÜBİTAK Marmara Research Center Energy Systems and Environmental Research Institute, Gebze, 2003.
4. <https://www.carsdirect.com/green-cars/a-brief-history-of-hybrid-cars>
5. A.A.Mr, İ.Yüksel, Electric Renault Fluence tool, lithium-ion battery modeling and battery management, Engineer and Machine, 52 (616), p.75-82, 2011.
6. R.G.Abaszade, S.A.Mamedova, F.H.Agayev, S.I.Budzulyak, O.A.Kapush, M.A.Mamedova, A.M.Nabiyev, V.O.Kotsyubynsky, Synthesis and Characterization of Graphene Oxide Flakes for Transparent Thin Films, Physics and Chemistry of Solid State, Vol. 22, №3, pp. 595-601, 2021.  
[DOI: 10.15330/pcss.22.3.595-601](https://doi.org/10.15330/pcss.22.3.595-601)
7. S.R.Figarova, E.M.Aliyev, R.G.Abaszade, R.I.Alekberov, V.R.Figarov, Negative Differential Resistance of Graphene Oxide/Sulphur Compound, Journal of Nano Research Submitted, Vol. 67, pp. 25-31, 2021.  
<http://dx.doi.org/10.4028/www.scientific.net/JNanoR.67.25>
8. R.G.Abaszade, O.A.Kapush, S.A.Mamedova, A.M.Nabiyev, S.Z.Melikova, S.I.Budzulyak, Gadolinium doping influence on the properties of carbon nanotubes, Physics and Chemistry of Solid State, Vol.21, №3, pp. 404-408, 2020.  
<https://doi.org/10.15330/pcss.21.3.404-408>
9. R.G.Abaszade, O.A.Kapush, A.M.Nabiyev, Properties of carbon nanotubes doped with gadolinium, Journal of Optoelectronic and Biomedical Materials, Vol.12, №3, pp. 61–65, 2020.  
[https://www.chalcogen.ro/61\\_AbaszadeRG.pdf](https://www.chalcogen.ro/61_AbaszadeRG.pdf)
10. R.G.Abaszade, Analysis of carbon nanotubes, AJP Fizika, Vol.26, №2, section: Az, pp.25-29, 2020.  
[http://www.physics.gov.az/physart/256\\_2020\\_02\\_25\\_az.pdf](http://www.physics.gov.az/physart/256_2020_02_25_az.pdf)
11. R.A.Namazov, R.G.Abaszade, Properties of graphene based solar panels (review), Ecoenergetics, №1, pp.3-8, 2022.  
<http://ieeacademy.org/wp-content/uploads/2022/05/ECOENERGETS-JOURNAL-No1.-2022.pdf>

## **Shamakhy Astrophysical Observatory**

**Sh.M.Shafiyeva**

*Azerbaijan University of Architecture and Construction, Baku, Azerbaijan,  
[shafishalala@gmail.com](mailto:shafishalala@gmail.com)*

**Abstract:** Shamakhy Astrophysical Observatory is an observatory in the greater Caucasus Mountains in Azerbaijan. It is known as after the medieval Persian astronomer Nasreddin Tusi. it's miles placed 22 km northwest of the town of Shamakhy, on the eastern slope of Pirqulu, at an elevation of 1500 m. It has 150–2 hundred clean, cloudless nights in line with 12 months.

**Keywords:** Shamakhi Observatory, Solar Physics, Photoelectric telescope, Satellites, Astrophysics, Space agencies, NewSpace.

### **1.Introduction**

Shamakhy Astrophysical Observatory named after Nasreddin Tusi of Azerbaijan National Academy of Sciences was established in 1959 by the decision (17 november) of the Council of Ministers of the ASSR. However, the history of scientific research in the field of astrophysics goes back to previous years. In 1927 a permanently operating astronomical expedition was created to study Astro climate in some regions of Azerbaijan. The expedition had to choose the favorable geographical location for the observatory in Kalbajar, Lachin, Shamakhy, Khizi and other regions of the republic. As a result of the investigations it was found out that, the Pirqulu region of Shamakhy is the most suitable place for the creation of a scientific center in this direction, and in 1953, it was decided to build an observation base and later an observatory. The Center is part of the Astrophysics Department (1954), then the Astrophysics Sector of the Academy of Sciences of Azerbaijan (ASA) (1956), within the ASA Institute of Physics and Mathematics. In addition to astronomical observations in 1953-59, the future design of the observatory, the training of specialists in the field of astronomy, telescope and equipment supply, the structure of the observatory, etc. serious work was underway on the issues. In 1957, the first telescope was installed at the Pirqulu Astronomical Station (Chromosphere-Photosphere Solar Telescope). In 1959, the issue of studying the astro-cyclicity of the area was solved by launching a 200-mm photoelectric telescope.

The Center has been incorporated into the ASA as an independent research institute since 1960. The observatory created on the initiative of prominent Azerbaijani scientists Hasan Aliyev and Yusif Mammadaliyev is located in the north-east of the Great Caucasus Mountains, 150km from Baku in the South Caucasus. Located at a distance (On the eastern slope of Pirqulu, the height 1500m, the geographical coordinates 48035'04"E/40046'20"N). Here, the number of clear lightly nights reaches 190-200 per year.

The first director of Shamakhy Astrophysics Observatory, academician Hajibey Sultanov (1960-1981). The academy has great services in the establishment and development of the observatory.

A two-meter telescope (produced by Carl Seyss of the German Democratic Republic), which was commissioned in September 1966, has particular importance for the Shamakhy Astrophysics Observatory. A special role was played by the former President of the ASA, academician Yusif Mammadaliyev and vice-president of the Academy, national poet Samad Vurgun in the purchase and operation of this popular optical telescope, which is the flag of Azerbaijan's experimental science. In addition, the Observatory has launched a horizontal solar telescope (1962), AST-452 telescope (1964), AZT-8 telescope (1970) and "Seyss 600" (1980) telescope.

## **2. Experimental details**

Astrophysical observations were intensively organized at the Shamakhi Observatory in 1960-1980. In that year, much attention was paid to the training of the country's personnel in the field of astrophysics. For this purpose, in 1976, by special order of the national leader Heydar Aliyev, the Department of Astrophysics was established at Azerbaijan State University. Today, the department plays an important role in developing a qualified workforce. By decision of the Cabinet in 1981, the Shamakhi Astrophysical Observatory was named after the great Azerbaijani astronomer Nasreddin Tusi. Sas Batavatbu (1973) and Agdara Observatory (1997) (Nakhchivan Autonomous Republic) were installed at the observatory. The observatory has been operating as an independent observatory since 2002 as part of the Nakhchivan branch of the National Academy of Sciences of Azerbaijan. The Baku branch of the Shamakhi Astrophysical Observatory plays an important role in coordinating the observatory's activities and establishing relationships with other structures of the ANAS. The observatory also has an astronomy museum. Museums generally play an important role in promoting observatories and observatories.

For achievements in astronomy in Azerbaijan, the International Astronomical Union named the asteroids found in 1970-2011 as "Azerbaijan", "ShAO", "Nizami", "Javid", "Muslim Magomayev", "Tusi" and "Ayyub Guliev". On the Mercury planet, a crater was called "Nizami", the crater on Mars was called "Nadir Ibrahimov", the deceased employee of the "SHAR", and a crater on the moon was named Nasreddin Tusi. At present, 13 of the names given to small celestial bodies, as well as to the crater of planets, are related to Azerbaijan. All this, undoubtedly, is an indication of the success of astronomy in Azerbaijan.

Reconstruction works were carried out in Shamakhi Astrophysical Observatory named after N.Tusi in 2009-2013 on the basis of relevant orders of the President of the Republic of Azerbaijan Mr. Ilham Aliyev. As a result of the attention and care shown by Mr. President to the Azerbaijani science, the living room of the observatory was completely renovated, its main corpus was renovated (a new astronomy museum, a large conference hall, etc.), a new laboratory building was built and telescopes were renovated, auxiliary facilities (dining-room, boiler-room, substation, etc.) were commissioned and large-

scale landscaping works were implemented. New communication lines (gas, water, electricity, telephone, etc.) that meet modern standards have been created, and the double-telescope has been fully automated and modernized.

The B-240 vacuum device was restored in 2007 to aluminum the surface of astronomical mirrors. A special building was built and put into operation to accommodate it. In 2013, for the first time in the history of the SAR, the process of aluminum aluminum mirrors was carried out by local specialists. The presence of this unique device allows the Shamakhi Astrophysics Observatory to regularly apply a layer of aluminum not only to its own mirrors, but also to the mirrors of regional observatories.

Scientific observations at the observatory are mainly carried out on two problems in the field of "Dynamics and Physics of Celestial Bodies": "Comprehensive study of physical variations in stars and nebulae" (study of non-stationary processes in celestial bodies and their nature) and "Solar Physics, Solar" physics and dynamics of system objects "(dynamics and physics of active bodies in the solar atmosphere, solar-Earth relations, study of planetary atmospheres and their satellites, comets, asteroids, motion of solar system objects, their structure, physics and evolution). In addition, the history of astronomy, theoretical research, radio astronomy, ionospheric scintillation of high-frequency radio signals and their dependence on various cosmic weather factors (solar activity, magnetic storms, etc.), etc. Research is also being conducted on the problems.

During the operation of the observatory, the staff published more than 100 monographs, textbooks, teaching aids, catalogs, popular science books on astronomy. 120 issues of the 40-year-old magazine "Circulation of the Balloon" have been published. The Azerbaijan Astronomical Journal has been published since 2006. In addition, the Observatory is closely involved in the publication of the international journal Sun and Geosphere, published in English. During SAR's existence, its staff has published more than 2,500 articles in foreign and local magazines.

Today, scientists and specialists trained at the Shamakhi Astrophysics Observatory successfully continue their activities in scientific institutions of many countries, including the United States, Israel, Ukraine, Russia and Turkey.

Graphene-based devices are widely used in space research [9-12].

### 3. Conclusions

A number of international and national symposiums and conferences were held at the Shamakhi Astrophysics Observatory. These include the Congress of the International Astronautical Federation (1972), conferences on the study of magnetic stars (1973, 1976), the Plenum of the Astronomical Council of the USSR Academy of Sciences (1984), the Tusi-800 Assembly (8 conferences during 1998-2002), Periodicity and Cosmological Problems "(2003)," International Conference Dedicated to the 60th Anniversary of the Founding of the SAR "(2013) and others.

During the activity of SAR, the observatory staff worked with foreign astronomers on a number of topical issues. Russia, Germany, Israel, Bulgaria,

Georgia, etc. on solar physics and the Sun-Earth problem. closely cooperates with individual astronomical organizations of the countries. Research in the field of stellar physics is carried out jointly with the staff of several Russian observatories (Russian Academy of Sciences, Sternberg State Astronomical Institute of Moscow State University, St. Petersburg State University, etc.). Russia, Ukraine, Tajikistan, etc. on the study of comets and meteors. joint work is being carried out with astronomers of the countries. SAR employees consistently and actively participate in the work of congresses, symposiums and conferences held in foreign countries, informing world astronomers about the work carried out at the observatory.

### References

- 1.A.Ş.Mehdiyev, B.M.Azizov, C.S.Mehdiyev, Aerospace monitoring, Baku, 2005.
2. B.M.Azizov, A.A.Abbaszade, Basics of aerospace research. Baku, 2004
- 3.V.M.Babazade, E.A.Mammadova, Fundamentals of Cosmos Geology, Baku, 2015.
- 4.<https://web.archive.org/web/20111006011521/http://anspress.com/index.php?a=2&lng=az&nid=117092>
- 5.<https://president.az/en/articles/view/3082>
- 6.G.V.Gonin, Space photography in the study of natural resources. L.: Nedra, 1980
- 7.B.C.Gao, K.B.Heidebmidt, A.F.H.Goetz, Derivation of Scaled Reflectance AVIRIS Data, Remote Sensing of Environment, Vol.44, pp.165-178, 1993.
- 6.R.G.Abaszade, S.A.Mamedova, F.H.Agayev, S.I.Budzulyak, O.A.Kapush, M.A.Mamedova, A.M.Nabiyev, V.O.Kotsyubynsky, Synthesis and Characterization of Graphene Oxide Flakes for Transparent Thin Films, Physics and Chemistry of Solid State, Vol. 22, №3, pp. 595-601, 2021.  
[DOI: 10.15330/pcss.22.3.595-601](https://doi.org/10.15330/pcss.22.3.595-601)
- 7.S.R.Figarova, E.M.Aliyev, R.G.Abaszade, R.I.Alekberov, V.R.Figarov, Negative Differential Resistance of Graphene Oxide/Sulphur Compound, Journal of Nano Research Submitted, Vol. 67, pp. 25-31, 2021.  
<http://dx.doi.org/10.4028/www.scientific.net/JNanoR.67.25>
- 8.M.W.Matthew, S.M.Adler-Golden, A.Berk, S.C.Richtmeier, R.Y.Levine, L.S.Bernstein, G.P.Anderson, Status of Atmospheric Correction Using a MODTRAN4-based Algorithm, SPIE Proceeding Algorithms for Multispectral, Hyperspect, Hyperspect Ultraspectral imagery VI, 4049, pp.199-207, 2000.
- 9.R.G.Abaszade, O.A.Kapush, S.A.Mamedova, A.M.Nabiyev, S.Z.Melikova, S.I.Budzulyak, Gadolinium doping influence on the properties of carbon nanotubes, Physics and Chemistry of Solid State, Vol.21, №3, pp. 404-408, 2020.  
<https://doi.org/10.15330/pcss.21.3.404-408>
- 10.R.G.Abaszade, O.A.Kapush, A.M.Nabiyev, Properties of carbon nanotubes doped with gadolinium, Journal of Optoelectronic and Biomedical Materials, Vol.12, №3, pp. 61-65, 2020.  
[https://www.chalcogen.ro/61\\_AbaszadeRG.pdf](https://www.chalcogen.ro/61_AbaszadeRG.pdf)
- 11.R.G.Abaszade, Analysis of carbon nanotubes, AJP Fizika, Vol.26, №2, section: Az, pp.25-29, 2020.  
[http://www.physics.gov.az/physart/256\\_2020\\_02\\_25\\_az.pdf](http://www.physics.gov.az/physart/256_2020_02_25_az.pdf)
- 12.R.A.Namazov, R.G.Abaszade, Properties of graphene based solar panels (review), Ecoenergetics, №1, pp.3-8, 2022.  
<http://ieeacademy.org/wp-content/uploads/2022/05/ECOENERGETICS-JOURNAL-No1.-2022.pdf>



## Obtaining and studying the properties of high-quality compost using biomass and wood ash

G.V.Shamilova

Azerbaijan State University of Oil and Industry, Baku, Azerbaijan,  
[gunel.shamilova04@gmail.com](mailto:gunel.shamilova04@gmail.com)

**Abstract:** Ash from biomass combustion consists mainly of inorganic components, as well as nutrients and pollutants contained in the fuel. The choice of the method of recycling and disposal of ash fractions depends on many factors.

**Keywords:** Composition, Wood ash, Biomass, Fertilizer.

### 1.Introduction

Conventionally, three ash fractions can be distinguished, although only two are formed, depending on the methods of flue gas cleaning in a boiler house or at a power plant.

Large, or grate, ash is formed in the furnace part and consists of mineral fuel residues, as well as impurity stones, unseparated metal products (nails, staples, etc.), etc. If combustion in a fluidized bed is used in a power plant, this fraction contains also the material of the layer (for example, sand).

Cyclone ash, also called fine or fly ash, is carried by flue gases and enters the centrifugal separators (cyclones) used for their purification and contains solid inorganic fuel components.

Very fine fly ash (third fraction) or condensate sludge from flue gas condensation systems is collected in filter separators (electric or fabric filters). If the biomass combustion plant is not equipped with filter

separators, this fly ash enters the atmosphere as residual dust.

Yield and composition of ash. Areas of accumulation of ash fractions with indication of their weight fraction in dry matter are shown schematically in fig. 1. The amount of ash and its composition depend on the fuel used and the combustion technology. Different types of wood differ in ash content. When wood waste is burned, more ash is usually generated. In the case of fluidized bed technology, the release of bed material increases the overall ash yield. The more completely the fuel burns in the chamber, the less ash is formed. On the other hand, the more ash is formed, the technologically easier it is to separate dust during flue gas cleaning.

In table. 1 shows the ratio of fractions in the dry matter of ash of different types of fuel. The actual amount of ash produced varies widely and is determined by combustion technology and fuel quality.

**Table 1. The composition of coarse ash fractions during the combustion of various types of fuel from plant biomass on a dry basis in % of the total ash volume**

<i>Dead bark</i>	<i>Fragmented and other wastes</i>	<i>Sawdust</i>	<i>Thatch and other cormophytic cultures</i>
70.0-90.0	65.0-95.0	25.0-35.0	85.0-95.0
15.0-30.0	15.0-35.0	55.0-75.0	7.0-10.0
7.0-15.0	7.0-15.0	15.0-25.0	10.0-20.0

The grain size of the ash depends on the type of fuel and the content of mineral substances in it. In coarse-grained ash, the grain size is determined by the proportion of sintered or slagged particles. The size of ash particles after the cyclone and fly ash depends on the applied dust collection technology. The maximum

grain size of fly ash is 0.1–0.6µm. Studies of the granulometric composition of ash fractions of different types of fuel showed that coarse ash particles are presented in a wide range: 10–150 µm. This is due to different slag formation associated with

the composition of the fuel and the type of boiler. The density of ash fractions does not depend on the

type of fuel, only on the size of the grains: the finer the particles, the lower their average density, as can be seen from the data in Table. 2.

**Table 2. Ash particle sizes and average density of ash fractions**

<i>Type of ash</i>	<i>Proportions, mkm</i>	<i>Average density, kg/m<sup>3</sup></i>
<i>Burning of the dead bark</i>		
grate ash	30.0-100.0	2.86
cyclone ash	3.0-200.0	2.59
fly small scale ash	0.3-10.0	2.515
<i>Burning of the sawdust</i>		
grate ash	10.0-30.0	3.021
cyclone ash	2.0-100.0	2.575
fly small scale ash	0.2-5.0	2.42
<i>Burning of the fragmented wastes</i>		
grate ash	15.5-50.0	2.866
cyclone ash	2.0-160.0	2.682
fly small scale ash	n.d.	n.d.

Ash contains all inorganic substances except nitrogen. Calcium is the main component of wood ash. The average concentrations of biogenic elements in the ash fractions of different types of fuel are given in

Table. 3, and for comparison, data on straw ash are given. The value of straw ash as a fertilizer is lower than wood ash, since its main component is silicon, the highest content of which is found in rice straw.

**Table 3. Content of nutrients in the ashes of different types of fuel**

<i>% of the dry mass</i>	<i>Fresh wood</i>	<i>Old wood</i>	<i>Thatch</i>
CaO	41.4	31.1	7.8
MgO	6	2.8	4.3
K <sub>2</sub> O	6.4	2.3	14.3
P <sub>2</sub> O <sub>5</sub>	2.6	0.9	2.2
Na <sub>2</sub> O	0.7	1.1	0.4

## 2. Experimental details

In fluidized bed combustion, the composition of the ash may vary due to the admixture of the bed material, usually silica sand (SiO<sub>2</sub>), and the nutrient content will be lower than in conventional combustion.

The nutrient content of wood waste ash is significantly lower than that of natural wood due to the wide variety of ingredients (the proportion of nutrients is lower). In fly ash, the content of most heavy metals increases significantly, since finely dispersed volatile compounds (for example, arsenic, cadmium, mercury, lead, zinc) condense on fly ash

during combustion and enter the atmosphere along with flue gases as they cool. Non-volatile compounds such as chromium and copper remain in the coarse ash.

Use of ash as fertilizer Traditionally, biomass ash is used as a fertilizer to improve soil fertility (as a substitute for lime due to its high calcium content - for compaction) in agriculture and forestry. the use of "ash from the last filter unit in the chimney", i.e. fine fly ash, as fertilizer is prohibited. Depending on the flue gas cleaning system, cyclone ash can be used as fertilizer. The accumulation of heavy metals in the

ash complicates its use, and primarily for fertilizer. The combustion chamber and air duct of the power plant must be designed in such a way that heavy metals are concentrated mainly in fine fly ash, characterized by the maximum ability to bind them. In addition, in order to avoid large losses of ash nutrients, when burning biomass, a fine dust separator should be used to ensure optimal separation of the three ash fractions.

### 3. Conclusions

Fertilizers containing wood ash are allowed to be applied only in finely dispersed (dust) or granular form, this is achieved only if the 0.1 mm fraction is not more than 0.2%, the 0.05 mm fraction is up to 0.05%, sieves 0.01 mm - up to 0.005%. In addition, wood ash can only be used as a fertilizer if it is labeled correctly.

### References

- 1.H.Insam, M.de Bertoldi, Microbiology of the composting process. In: Golueke, C., Bidlingmaier, W., de Bertoldi, M., Diaz, L. (Eds.), *Compost Science and Technology*. Elsevier, pp.25–48, 2007.  
[https://www.scrip.org/\(S\(vtj3fa45qm1ean45vffcz55\)\)/reference/ReferencesPapers.aspx?ReferenceID=1651295](https://www.scrip.org/(S(vtj3fa45qm1ean45vffcz55))/reference/ReferencesPapers.aspx?ReferenceID=1651295)
- 2.H.K.Jokinen, O.Kiikkila, H.Fritze, Exploring the mechanisms behind elevated microbial activity after wood ash application. *Soil Biol. Biochem.* №38, pp.2285–2291, 2006.  
[https://www.researchgate.net/publication/248447523\\_Exploring\\_the\\_mechanisms\\_behind\\_elevated\\_microbial\\_activity\\_after\\_wood\\_ash\\_application](https://www.researchgate.net/publication/248447523_Exploring_the_mechanisms_behind_elevated_microbial_activity_after_wood_ash_application)
- 3.P.Khana, R.Raison, R.Falkiner, Chemical properties of ash derived from Eucalyptus litter and its effects on forest soil. *Forest Ecol. Manage.* 66, pp.107–125, 1994.

As part of the control of emissions from biomass combustion plants, the competent authority may require the processing or disposal of ash.

To obtain the highest quality fertilizer, the ash must not be mixed. coarse ash is allowed to be used as lime or potash fertilizer, maximum 30% can be added to lime carbonate type fertilizer. In order for the ash to meet the category "lime fertilizer from the combustion of plant matter", the CaO content in it must be at least 30%. Table data. 3 indicate that wood ash meets this requirement.

Ash can also be recycled along with organic waste. According to annex 1 of the Decree on the disposal of biowaste on agricultural, forest and garden soils, coarse ash can be added to biowaste during or after processing. If the ash is added to compost or fermentation products after processing, the resulting mixtures are called organo-mineral fertilizers

<https://agris.fao.org/agris-search/search.do?recordID=NL9500596>

- 4.N.Koivula, T.Raikkonen, J.Ranta, K.Hanninen, Ash in composting of source-separated catering waste. *Bioresour. Technol.* Vol.93, pp.291–299, 2004.

<https://cris.vtt.fi/en/publications/ash-in-composting-of-source-separated-catering-waste>

- 5.L.Leita, M.De Nobili, C.Mondini, G.Muhlbachova, L.Marchiol, G.Bragato, M.Contin, M., Influence of inorganic and organic fertilization of soil microbial biomass, metabolic quotient and heavy metal bioavailability. *Biol. Fertil. Soils*, Vol.28, pp.371–376, 1999.

<https://link.springer.com/article/10.1007/s003740050506>

## **Study of the composition of silicate concrete based on small fillings**

**S.M.Akbarova, V.U.Shahmarov, T.İ.Mustafayev**

*Azerbaijan University of Architecture and Construction, Baku, Azerbaijan,  
[sev10@rambler.ru](mailto:sev10@rambler.ru) , [vshahmarov@gmail.com](mailto:vshahmarov@gmail.com) , [teomustafayev@mail.ru](mailto:teomustafayev@mail.ru)*

**Abstract:** One of the most important tasks of the modern building materials industry is the development of energy-saving technologies and the local production of highly efficient building materials, in which autoclaved materials play an important role. In industrial construction (in terms of value), autoclaved masonry materials are second only to precast concrete. In connection with the development of the production of autoclave materials and products, there is a need for an in-depth study of the phase composition and properties of the resulting neoplasms, as well as the patterns of the process of fixing materials in an autoclave. The most important task of this study is to find effective methods for the production of autoclave products with increased strength and durability. The modern development of concrete technology is inextricably linked with the development and use of high-quality types of adhesives that are economically, technologically and technically effective.

**Keywords:** Carbonate rock, Quartz sand, Lime, Silicate concrete.

### **1.Introduction**

At present, silicate concrete is one of the most demanded materials in modern construction in the world. For example, according to Global Reach Consulting (GRC), the production of silicate concrete is currently growing rapidly in neighboring Russia. In 2011, the production of silicate concrete in Russia increased by 30% [1].

Market research conducted by Index Box showed that the silicate concrete market is still small enough for construction, with consumption increasing by 23% at the end of 2012, practically supplying the market with locally produced products. The demand for this building material is increasing every year. Such trends are explained by the advantage of high thermal insulation properties of silicate concrete, incombustibility, light and durable environmentally friendly raw materials. It is made from pure raw materials and is characterized by relatively low prices. At present, a wide range of products necessary for the construction of residential, social and industrial buildings in the world are made from silicate concrete [2].

The use of silicate concrete in individual construction increased its share to about 40%. [3] Although silicate concrete has high porosity, it is non-hygroscopic, dries quickly, and does not warp when wet. Under normal conditions, high porosity gives silicate concrete almost unlimited frost resistance. German chemist V.M. The discoveries of Michaelis had a

significant impact. The essence of the discovery was that the lime-sand mixture solidified in an autoclave at a pressure of about 0.8MPa for 9-10 hours [4]. Since the end of the 19th century, the production of silicate materials has been successfully developing in world practice.

Among the pioneers of that time who devoted their research to the field of silicate concretes, the following Russian scientists should be noted. A.A.Baikov, A.B.Volzhinsky, V.P.Nekrasov. The 1930s marked the beginning of research into autoclaved concrete technology for the former Soviet Union. The production of autoclaved concrete began in the mid-1950s. Silicate concrete has only become widely used since the 1960s.

The fine aggregate used in the study is a carbonate rock. Densely structured natural rocks are the main raw material base for the production of aggregates. Rocks are mineral masses that make up the earth's crust with a more or less stable composition and structure. If the rock is composed of a single mineral, it is called a simple or monomineral rock, and if it is composed of several minerals, it is called a complex or polymineral rock. Of particular importance in the production of aggregates for concrete are carbonate rocks [5].

Graphene-based materials have exceptional services in the field of enrichment of building materials [6-10].

**Table.1.Granular composition of carbonate rock**

Size of sieve openings, mm	Residue in sieves, %		
	Separate residue, a <sub>i</sub>	Complete residue, A <sub>i</sub>	Requirement of GOST-32496
5	2.3	2.3	0-10
2,5	14.7	17.0	15-35
1,25	15.4	32.4	30-50
0,63	13.2	45.6	40-65
0,315	24.5	70.1	65-90
0,16	22.8	92.9	90-100
Part passing through a sieve with a hole of 0.16 mm	7.1		0-10

The granular composition of sand is expressed by the modulus of dimension:

$$Mi = \frac{A_{2,5} + A_{1,25} + A_{0,63} + A_{0,315} + A_{0,16}}{100} = 2,6$$

**2. Experimental details**

According to the results of sieve analysis, the fineness factor of expanded clay concrete is determined as 2.6 (Mi). Sand according to the dimensional module according to GOST-8736-93 is divided into 8 groups. As a result of the test, it was found that the test material is large-sized.

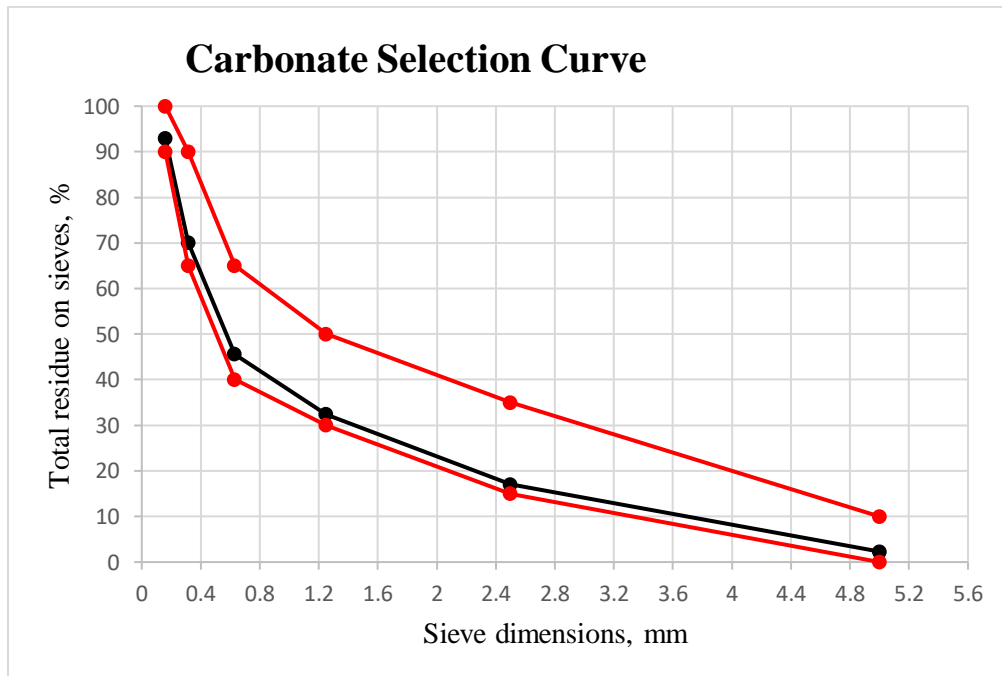

Figure 1. Carbonate selection curve.

Influence of carbonate aggregates on the strength of silicate concrete: Carbonate aggregate was added to the lime-silicone mixture in the ratio of 1:2, 1:3 and 1:4. The silicate concrete mixture is kneaded according to GOST 25214-82. A sample was made from the concrete mix we received. The compressive strength of the samples was determined. Our results

are shown in the table. The compressive strength of silicate concrete according to the standard is B5; B7,5; B10; B12,5; B15; B20; B25; B30; B35; B40; B45; B50; B55; B60 classes and M75; M100; M125; M150; M200; M250; M300; M350; M400; M450; M500; M600; M700 there are brands.

**Table 2. Influence of carbonate rock on the strength of silicate concrete**

The ratio of glue and filler, g/f	Average density of concrete, kq/m <sup>3</sup>	Age of sample days, day	Sample dimension, mm	Strength value of compression, MPa		Average result, MPa
1:2	1735	28	150x150x150	14.37	14.69	14.53
1:3	1762	28	150x150x150	18.01	18.32	18.16
1:4	1773	28	150x150x150	16.95	17.28	17.11

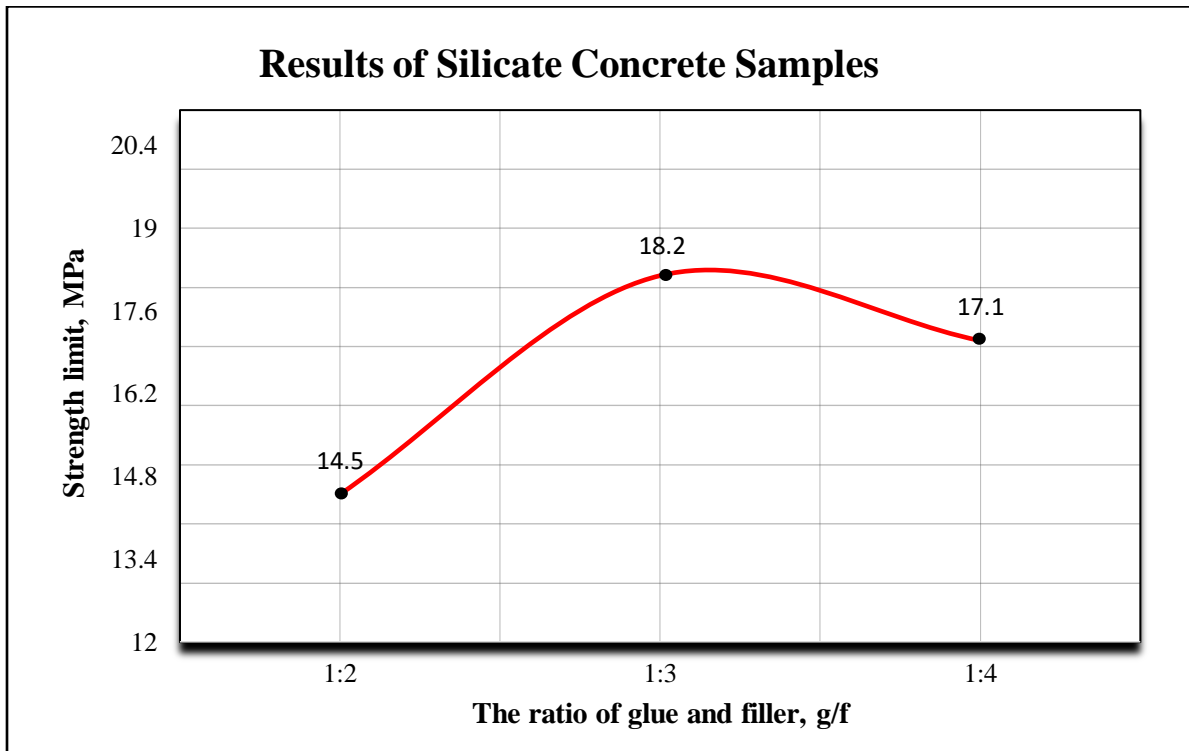

*Figure 2. Results of silicate concrete samples*

**Table 3. Influence of carbonate rock on the strength of silicate concrete**

Percentage of gypsum dilution,%	Average density of concrete, kq/m <sup>3</sup>	Age of sample days, day	Sample dimension, mm	Strength value of compression, Mpa		Average result, Mpa
1	1780	28	150x150x150	17.45	17.70	17.57
2	1779	28	150x150x150	19.28	19.70	19.49
3	1790	28	150x150x150	22.13	22.42	22.27
4	1795	28	150x150x150	24.01	24.18	24.09
5	1806	28	150x150x150	22.76	23.01	22.88

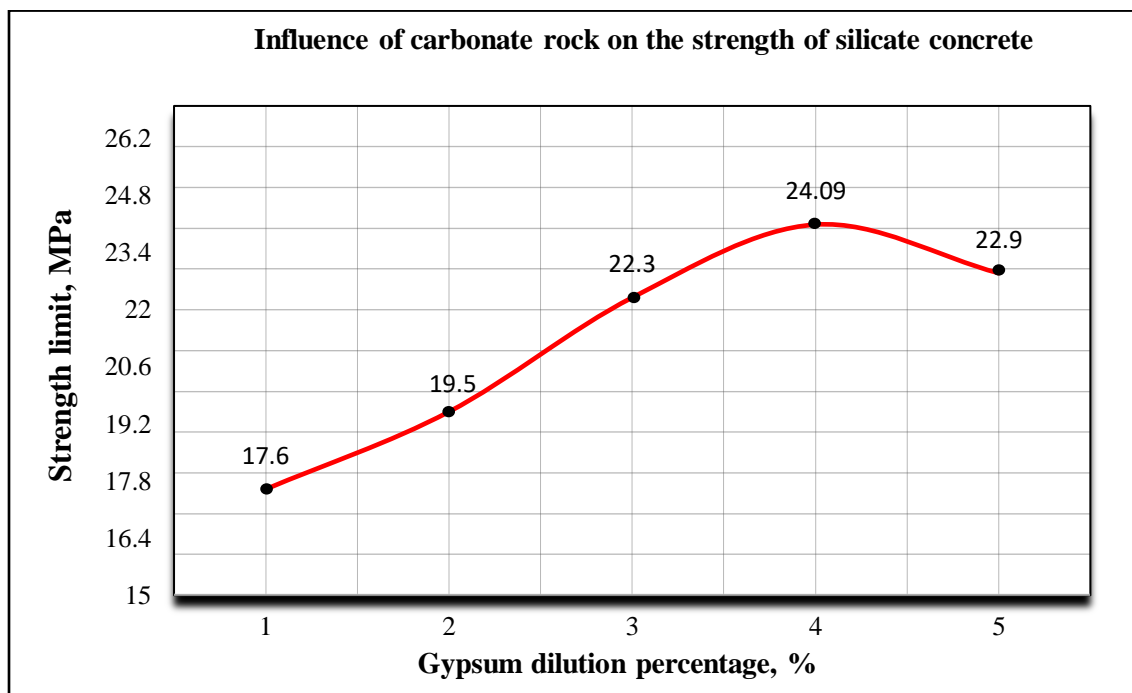

*Figure 3. Influence of carbonate rock on the strength of silicate concrete*

In accordance with the requirements of the standard (GOST 25214-82), the results obtained showed that when adding up to 4% gypsum to lime glue, more

durable silicate concrete of class B20 M250 is obtained.

**3. Conclusions**

The article is devoted to the study of the composition of silicate concrete based on fine aggregates. The composition of silicate concrete was prepared using lime as an adhesive. A binder, filler and water were used to prepare the concrete composition. The effect

of carbonate filler on the properties of silicate concrete has been studied and it has been established that the addition of 4% gypsum to lime glue gives high results in terms of compressive strength of silicate concrete.

## References

- 1.A.B.Dombrovsky, Ya.M., Paplavskis Experience of production, design and application of aerated concrete products in residential, industrial and agricultural construction, Construction materials, №6 pp.16-18, 1983.
- 2.P.V.Eving, Economic efficiency of application and prospects of development of production of cellular concrete products, Production and application of silicate concrete, Sat. tr. NIPISilikatobetona. - Tallinn, Vol.15, pp.162-178, 1981.
- 3.Ya.A.Rector Effectiveness and prospects of using progressive materials in construction. M.: Stroyizdat, 199 p., 1978.
- 4.E.M.Chernyshov, Management of the processes of structural formation and the quality of silicate autoclaved materials (questions of methodology, structural materials science, engineering and technological tasks): Dis. Dr. techn. science. Tom.1, Voronezh, 523 p., 1988.
- 5.T.A.Hagverdiyeva, Technology of Heavy Concrete Aggregates, Baku, pp.13-14, 2006.
- 6.R.A.Namazov, R.G.Abaszade, Properties of graphene based solar panels (review), Ecoenergetics, №1, pp.3-8, 2022.  
<http://ieeacademy.org/wp-content/uploads/2022/05/ECOENERGETS-JOURNAL-No1.-2022.pdf>
- 7.Kh.M.Popal, R.G.Abaszade, Research and modeling of hybrid energy systems (review), Ecoenergetics, №1, pp.65-69, 2022.  
<http://ieeacademy.org/wp-content/uploads/2022/05/ECOENERGETS-JOURNAL-No1.-2022.pdf#page=66>
- 8.S.R.Figarova, E.M.Aliyev, R.G.Abaszade, R.I.Alekberov, V.R.Figarov, Negative Differential Resistance of Graphene Oxide/Sulphur Compound, Journal of Nano Research Submitted, Vol.67, pp.25-31, 2021.  
<http://dx.doi.org/10.4028/www.scientific.net/JNanoR.67.25>
- 9.R.G.Abaszade, O.A.Kapush, S.A.Mamedova, A.M.Nabiyev, S.Z.Melikova, S.I.Budzulyak, Gadolinium doping influence on the properties of carbon nanotubes, Physics and Chemistry of Solid State, Vol. 21, No. 3, pp. 404-408, 2020.  
<https://doi.org/10.15330/pcss.21.3.404-408>
- 10.R.G. Abaszade, O.A. Kapush, A.M. Nabiyev, Properties of carbon nanotubes doped with gadolinium, Journal of Optoelectronic and Biomedical Materials, Vol.12, №3, pp.61–65, 2020.  
[https://www.chalcogen.ro/61\\_AbaszadeRG.pdf](https://www.chalcogen.ro/61_AbaszadeRG.pdf)



## **Development of mathematical models of complex oil refining technological processes**

**A.A.Safarova, H.M.Mammadli**

*Azerbaijan State Oil and Industry University, Baku, Azerbaijan,  
[avgsafa@rambler.ru](mailto:avgsafa@rambler.ru) , [khanman.ea@gmail.com](mailto:khanman.ea@gmail.com)*

**Abstract:** At present, the level of economic development in oil-oriented countries depends on the efficiency of the level of refining of crude oil extracted from oil fields. On the other hand, the proper management of these technological processes and high productivity depend directly on the development of mathematical models that can accurately describe these processes. The paper deals with the construction of a deterministic linear mathematical model of the technological complex of primary oil refining, which adequately describes the current technological conditions.

**Keywords:** Mathematical models, Oil refining, Experimental-statistical methods, Rectification column, Regression model, Crude oil consumption.

### **1.Introduction**

One of the important requirements in the development of mathematical models of technological processes is the operative and accurate measurement of all input and output variables. Analysis of the scientific studies in the automation of technological processes, much attention has been paid to the optimization of static modes of complex systems, which include a large number of different technological devices.

Currently, there are analytical and purely experimental modeling methods for building mathematical models of complex technological processes. Based on these modeling methods, it is possible to build a mathematical model for any technological system, regardless of the degree of study of technological processes and effects that occur in the system as a whole [1-2].

Development of mathematical models of complex oil refining technological processes means mathematically finding the existing dependencies between the input and output variables of the process. The building of mathematical models that describe these dependencies is usually carried out on the basis of theoretical analysis, the basis of the physical and chemical regularities of the object, logical analysis, generalization of previous experiments .

### **2. Experimental details**

Experimental-statistical methods allow to establish mathematical dependences between the variables that characterize the static modes of technological processes in the form of linear and nonlinear

For solving problems of optimizing technological processes of oil refining, preference was given to optimizing their statistical regimes based on models with more preferable definitions. However, given the lack of information about the current state of the technological process, it can be considered that this approach does not always achieve effective results. Therefore, in the paper preference is given to the building of mathematical model for atmospheric unit that would allow taking into account the above lack of information and thereby control the process in more optimal modes than the existing technological modes [3-4].

Experimental-statistical methods used in the building of mathematical models of technological processes allow to establish mathematical dependences between a large number of variables, to detect the existing dependence between any two variables, as well as to quantify dependencies for complex technological complexes of any degree of difficulty. These methods are based on the processing and processing of the results of experiments conducted with the help of a mathematical statistical apparatus [5-6].

Modeling of power generation systems is a topical issue [7,8].

regression equations. In order to identify mathematical models in the research work, the required a priori information on input and output variables during the normal operation of the

technological complex was collected. This initial statistical material is given in the table 1.

It should be noted that in terms of impact on the acquisition of target products as an object control, the main device is the K-1 column, which is necessary for the production of degassed oil and unstable gasoline from hydrotreated oil. The main technological mode parameters that characterize this device are the temperature at different points - above and below the column, the level below the column, the pressure above the column. In the research work, in the development of mathematical models of the rectification column K-1, which is the main apparatus of the atmospheric block of the technological complex of primary processing of oil in general, mathematical models in linear form on the output coordinates of the technological process as follow :

$$y^* = B_0 + \sum_{i=1}^n B_i x_i \quad (1)$$

In nonlinear form :

$$y^* = K_0 + \sum_{i=1}^n K_i x_i + \sum_{i=1}^n \sum_{j=i+1}^n K_{ij} x_i x_j + \sum_{i=1}^n K_{ii} x_i^2 \quad (2)$$

Here,  $y^*$  - the output coordinate;  $K_0$  and  $B_0$  - free coefficients;  $B_i, K_i, K_{ij} (i, j = \overline{1, n}, i \neq j)$  - linear and interaction ratios, respectively;  $K_{ii} (i = \overline{1, n})$  - quadratic effect coefficients;  $x_i (i = \overline{1, n})$  - input parameters;  $n$  - characterizes the number of input parameters.

The multidimensional correlation method was used to find the coefficients of the mathematical models of the atmospheric block (1) and (2) of the technological complex of primary oil refining.

Considering that the technological complex of primary refining of oil production profile oil belongs to the class of fire-explosion hazard objects of I degree, the method of passive experiment was preferred during the collection of this statistical information. At the same time, changes in crude oil consumption and specific gravity as an indicator of quality were taken into account throughout the range during the collection of primary statistical material.

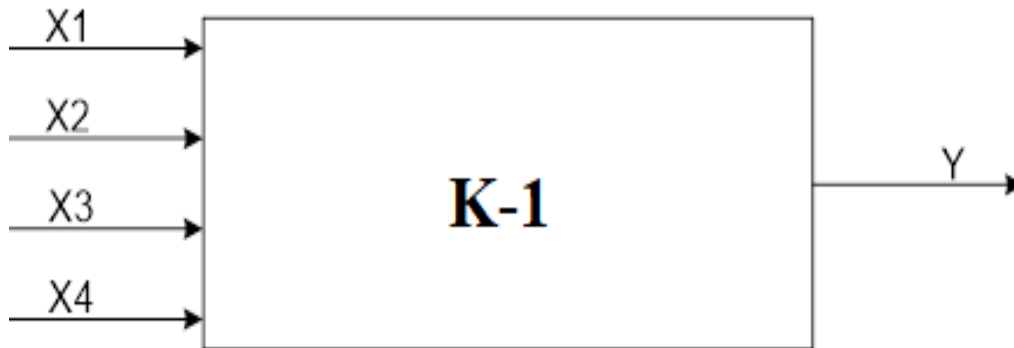

Figure 1. Structural diagram of K – 1 column as a modeling object

$X_1$ - specific gravity of raw material, kg/sm<sup>3</sup>  
 $X_2$ - consumption of raw materials ,kg / hour  
 $X_3$ - pressure in column K1, atm  
 $X_4$ - temperature above column K1 ,°C  
 Y- - unstable gasoline consumption , kq/saat  
 Restriction for input and control parameters

$854 \leq X_1 \leq 861$   
 $205 \leq X_2 \leq 217$   
 $4 \leq X_3 \leq 5$   
 $140 \leq X_4 \leq 160$   
 $41 \leq Y \leq 44$

**Table 1 Initial statistics of the technological process of primary oil refining**

№	X1	X2	X3	X4	Y
1	854	205	4	140	41
2	855,3	208,1	4,1	142	41,3
3	858,6	207,6	4,3	143	41,5
4	858	210,2	4,11	147	41,9
5	859	206,4	4,4	145	42
6	860	211	4,6	149	42,6
7	860,3	209,3	4,23	150	42,8
8	857	210,5	5	151	43,1
9	856	212	4,9	151,6	43,52
10	857,6	215,9	4,87	152	41,31
11	855	216,2	4,56	140	43
12	855,6	213	4,21	160	43,43
13	855,3	214,8	4,32	155,9	43,25
14	855,9	217	4,59	143,7	41,85
15	856,9	216,3	4,12	141,3	41,69
16	861	206	4,6	148	42,45
17	854,1	211,5	4,5	146,6	42,8
18	856,6	207,7	4,7	143,8	44
19	857,5	211,5	5	144,5	41
20	859,9	217	4,94	148	42,36
21	860,4	216,2	4,78	159	42,89
22	860	214,3	4,06	156,1	43,15
23	859,6	215,6	4,4	158	43,37
24	857,4	216,6	4,82	159,3	42,76
25	861	217	5	160	44

The solution of the problem

$$Y = f(X_1, X_2, X_3, X_4) \rightarrow \max$$

The regression equation in linear form is determined as

$$\text{follow: } Y = B_0 + B_1 X_1 + B_2 X_2 + B_3 X_3 + B_4 X_4 \rightarrow \max$$

**Table 2 Obtained coefficients of regression model**

№	X1	X2	X3	X4	Y
1	2	3	4	5	6
1	854	205	4	140	41
2	855,3	208,1	4,1	142	41,3
3	858,6	207,6	4,3	143	41,5
4	858	210,2	4,11	147	41,9
5	859	206,4	4,4	145	42
6	860	211	4,6	149	42,6
7	860,3	209,3	4,23	150	42,8
8	857	210,5	5	151	43,1
9	856	212	4,9	151,6	43,52
10	857,6	215,9	4,87	152	41,31
11	855	216,2	4,56	140	43
12	855,6	213	4,21	160	43,43
13	855,3	214,8	4,32	155,9	43,25
14	855,9	217	4,59	143,7	41,85
15	856,9	216,3	4,12	141,3	41,69
16	861	206	4,6	148	42,45
17	854,1	211,5	4,5	146,6	42,8
18	856,6	207,7	4,7	143,8	44
19	857,5	211,5	5	144,5	41
20	859,9	217	4,94	148	42,36
21	860,4	216,2	4,78	159	42,89

1	2	3	4	5	6
22	860	214,3	4,06	156,1	43,15
23	859,6	215,6	4,4	158	43,37
24	857,4	216,6	4,82	159,3	42,76
25	861	217	5	160	44
26	0,08595	0,36675	-0,01328	-0,03975	64,933
27	0,029488	0,517523	0,04755	0,079777	68,49179
28	0,385094	0,768765	#N/A	#N/A	#N/A
29	3,131325	20	#N/A	#N/A	#N/A
30	7,402456	11,82001	#N/A	#N/A	#N/A

Obtained coefficients of regression model are given in the table 2.

MODEL PARAMETERS :

$$B_0 = 64.933$$

$$B_1 = -0.03975$$

$$B_2 = -0.01328$$

$$B_3 = 0.36675$$

$$B_4 = 0.08595$$

$$Y = B_0 + B_1 X_1 + B_2 X_2 + B_3 X_3 + B_4 X_4 + B_5 X_5 \rightarrow \max$$

$$Y = 64933 - 0.03975X_1 - 0.01328X_2 + 0.36675X_3 + 0.08595X_4 \rightarrow \max$$

Correlation coefficient ----- 0, 98

Fisher criterion ----- 1.17

Number of observations ----- 16

Average squared inclination ----- 1, 78

Thus, since the numerical value of Fisher coefficient adequacy index of the mathematical developed model is greater than its table value ( $F_{exp} > F_{tab}$ ), set correlation criterion  $R$  is close to the unit ( $0.98 \approx 1$ ) and residual error  $\varepsilon$  is very small, the developed mathematical regression model is adequate.

### 3. Conclusions

Physically justified mathematical formalization of the problem of optimal management of the atmospheric block of the primary oil refining technological complex has been performed;

The parameters of the controlled and monitored were determined for the K-1 apparatus, which is the main apparatus in the technological structure. Mathematical

modeling which is the main topic of the paper is considered. According to the statistics of the Baku Oil Refinery named after Heydar Aliyev, a mathematical model of the atmospheric column (K-1) has been developed. Using the Microsoft Office Excel program an identification problem is solved and the adequacy of the model is checked.

### References

1.P.Robinson, Petroleum Processing Overview. In book: Practical Advances in Petroleum Processing. 78p., 2007.

[https://www.researchgate.net/publication/226038766\\_Petroleum\\_Processing\\_Overview](https://www.researchgate.net/publication/226038766_Petroleum_Processing_Overview)

2.Statistical Models: Theory and Practice by David A. Freedman .University of California, Berkeley, 459 p., 2009.

<https://pdfroom.com/books/statistical-models-theory-and-practice/OX6231XL54>

3.Michael & Cho, Hokwon. Golberg, (2010). Introduction to Regression Analysis, Edition: Revised

and Updated Edition Publisher: Wessex Institute of Technology, WIT press ISBN: 978-1-85312-624-6, 2010.

<https://www.researchgate.net/publication/264700780>  
[Introduction to Regression Analysis](#)

4.V.Bukhtoyarov, V.Tynchenko, E.Petrovsky, S.Dokshanin, V.Kukartsev, Research of methods for design of regression models of oil and gas refinery technological units. IOP Conference Series: Materials Science and Engineering. 537 p., 2019.

<https://www.researchgate.net/publication/333836717>  
[Research of methods for design of regression models of oil and gas refinery technological units](#)

5.M.H.Ahmad, R.Adnan, C.K.Lau, D.Z.Mohd, Comparing Least-Squares and Goal Programming Estimates of Linear Regression Parameter. MATEMATIKA: Malaysian Journal of Industrial and Applied Mathematics, 21, pp.101–112, 2005.

<https://matematika.utm.my/index.php/matematika/article/view/519/512>

6.M.B.Grzelak, A.G.Patrycja, Application of Linear Regression for Evaluation of Production Processes Effectiveness. In book: Innovations in Industrial Engineering, pp.36-47, 2022.

<https://www.researchgate.net/publication/352713715>  
[Application of Linear Regression for Evaluation of Production Processes Effectiveness](#)

7.R.A.Namazov, R.G.Abaszade, Properties of graphene based solar panels (review), Ecoenergetics, №1, pp.3-8, 2022.

<http://ieeacademy.org/wp-content/uploads/2022/05/ECOENERGETS-JOURNAL-No1.-2022.pdf>

8.Kh.M.Popal, R.G.Abaszade, Research and modeling of hybrid energy systems (review), Ecoenergetics, №1, pp.65-69, 2022.

<http://ieeacademy.org/wp-content/uploads/2022/05/ECOENERGETS-JOURNAL-No1.-2022.pdf#page=66>

## **The dynamic and interactive nature of computational processes**

**A.N.Becanova**

*Azerbaijan State Oil and Industry University, Baku, Azerbaijan,  
[aytac.becanova@mail.ru](mailto:aytac.becanova@mail.ru)*

**Abstract:** The dynamic and interactive nature of computational processes stems from the fact that all factors governing natural occurrences and their relationships, as well as the system's boundaries and constraints, are unknown to scientists working in a specific field. The goal of this branch of study is to use a distributed exascale computing system based on knowledge of variables and their interactions, as well as the computing system's boundaries and constraints. Scientific conventional programs that now execute on computer systems are the main rules in distributed exascale computing systems. A set of basic rules should be addressed in the specific field of research in order to recognize and uncover unknowns. These are the guidelines to follow.

**Keywords:** Distributed exascale computing, High performance computing, Resource discovery, Dynamic and interactive events, Request Nature Set (RNS).

### **1.Introduction**

The dynamic and interactive character of computational processes is owing to the fact that all factors governing natural occurrences and their relationships, as well as the system's boundaries and constraints, are unknown to scientists working in a specific field. The goal of this subfield of research is to use a distributed exascale computing system based on knowledge of variables and their interactions, as well as the computing system's boundary and constraints [1,2].

Principle rules in distributed exascale computing systems are scientific classical programs now running on computer systems [3]. In the unique field of science, a set of basic criteria should be considered in order to recognize and uncover unknowns. Over the last 50 years, these rules have been incorporated in computer and processing systems.

Traditional computer systems respond to queries using mechanisms that were considered during the system's initial design [4]. In distributed exascale computing systems, on the other hand, executable elements with new processes are created or a new relationship between the existing processes may be formed during the execution of a program and in response to requests; thus unpredictable resources are requested from the existing processes. The dynamic and interactive character of computer processes causes such unanticipated requests to be generated during execution.

In contrast to typical computer systems, distributed exascale computing systems generate requests with a

dynamic and interactive nature that were not anticipated when the system was designed [5]. This is because the regulated laws on natural events were discovered [6]. In the process of discovering the controlled laws on natural occurrences, a new process or link between processes that explain natural events may be produced. If the system's bounds for discovering natural occurrences do not match the nature of the events, a new link between processes describing events and computing elements outside the system emerges [7].

In computing systems, in response to the request of the process, new requests are created or a new relationship is created between processes inside the system and the environment, leading to creation of a new process. In all of the aforementioned items, a request is formed in the computational process for which there is not defined any controlling and managing structure at the time of designing the system. The resource management should be able to create appropriate controlling and managing structure for the requests during the execution of the program.

Examining the nature of scientific programs that need networked exascale computing systems [8], it can be deduced that the frequency of requests that cannot be answered by the local system grows in such applications [5].

This is related to the emergence of a new global activity [6] for responding to requests with a dynamic and interactive nature, as well as the lack of a

regulating and managing structure to answer to such demands [6, 9]. The dynamic and interactive event results in the emergence of a new process with new relationships both inside and outside the system, elements that were not anticipated in the system's response structure when it was designed. One of the latest achievements of science is increasing the opportunities for the study and application of graphene-based nanomaterials [12-18].

**2. Experimental details**

The dynamic and interactive nature of computational processes influences RD in two ways. First, the dynamic and interactive nature increases the frequency of calling RD, meaning that functionality of RD is changing. In traditional computing systems, RD is being called for finding a new resource which has the capability of the response to a request of the process. During the occurrence of the event with dynamic and interactive nature in computational processes, RD is used for the response outside of the boundary and limitations of the system [5]. The second influence of the dynamic and interactive nature on RD is related to RNS and the Request Imaging (RI). In traditional computing systems, if Alpha process in response to the request of Beta causes calling of RD, during finding appropriate resources, RNS related to Alpha process will not change.

In this study, the Request Nature Set of the Alphaprocess is defined as Eq. (1):

As can be seen in the Eq. (1), RNS related to the Beta request is defined based on four spaces which include the nature of the request, the type of the request, and the time and location constraints of the request. In

RNS, permission and allocation of a resource to the process can be defined.

In Eq. (1), the nature of a request is the cause of formation of Beta in the Alpha process. The Alpha process is part of a global activity. In traditional and distributed exascale computing systems, the global activity is a set of related activities which are responded by different elements of the computing system. The cause of formation of the global activity in distributed computing systems is due to the fact that an initial request existed in the computing element, part or all of which cannot be responded by the local computing element. To response to the request, the local computing system sends the request or part of the request to other computing elements of the system. Each computing element of the global activity is responding to part of the request. In Fig. 1, the global activity in distributed exascale computing systems is depicted [6].

As shown in Figure 1, a request is created in machine A1, which is unable to reply to the request or any part of it. The request (or a portion of it) is transformed to another machine in the system using the global activity method. If each machine is equated to a point on the page, a line termed global activity is formed, with each point representing a computing unit that answers to a portion of the request. The request is completed in machine Az, which means that all aspects of the request are handled by global activity components. The request is inside the system from A1 to Ai in the computer system indicated in Fig. 1. There is no element in the computing system that can reply to the request in machine Ai (or part of the request).

$$\begin{aligned}
 & \text{Defined based on} \\
 & RNS_{Alpha}(Beta) \quad \begin{matrix} \vdots \\ \vdots \\ \vdots \end{matrix} < \\
 & \hspace{10em} \text{space} \\
 & \overbrace{Request_{Nature}, Request_{type}, Request_{time}, Request_{location}, RAC_{Beta}} >, < \\
 & \hspace{10em} \text{operation} \\
 & \overbrace{Permission, Allocation} >>
 \end{aligned} \tag{1}$$



Figure 1. A schematic of the global activity in distributed exascale computing systems

The initial request that is formed in machine A1 is called Tetra. As Tetra cannot be responded in machine

A1, it is transformed to machine A2. If the concept of transformation in the system is being in such a way

that during the transformation of Teta, the cause of the creation of the request and the reason that Teta cannot be responded is being transformed to A2, Teta is memory oriented. Otherwise, if Teta initiates its activity as a local request in machine A2 and has no information about its situation in machine A1, it is called memory less.

If Teta is memory oriented, the reason of transformation and failure to reply to the previous computing element, as well as the components that did respond in the prior element, are saved. As a result, each computing element has precise knowledge on the nature of the request, its origin, and the reason for its transformation. If Teta is memory-constrained, however, the transformation from one computing unit to another is treated as a new request that must be handled by the new computing element.

The resource management system defines the type of request in Eq. (1). The kind of request in [6], for example, falls into one (or a mix) of the four categories of I/O, file, process, and memory. Other types of resources can also be utilized. The time limitation of the request in Eq. (1) relates to the time necessary to respond to each request. This time is dictated either by the computing element that produces the global activity or by the request's transition from one computing element to another. The location constraint of the request in Eq. (1) relates to whether or not the answer to the Beta request should be performed in a specified place. The Beta request should be completed at the computing element where the global activity is started in some cases. As a result, the resource management system should handle global activity in such a way that the global action is completed in the element where it was started [10]. In Eq. (1),  $RAC_{\beta}$  denotes permission of access to a resource and allocation of the resource. For the Beta request, in machine number  $i$ , there should be a permission of access to the resource that has capability to respond to the Beta request (or part of it) in machine number  $i + 1$ . Permission of access and allocation of a resource to the request are granted by the load balancer if machine number  $i + 1$  is in the local computing system [11], but are granted by RD if machine number  $i + 1$  is outside the local computing system.

In traditional HPC systems, during the response to the Beta request, RNS is not changing by the load balancer and RD. This means that either RNS related to the Beta request is created in the computing element that creates the global activity with no changes during the global activity (if the request is

memory oriented), or when the Beta request is transformed to the computing element, RNS is created by the resource management system which will be constant during the existence of the process containing the Beta request (if the request is memory less).

When a request is created in a system, each request is considered in the triple form as  $\langle \text{time, type, location} \rangle$  ( $\langle t, \tau, l \rangle$ ). When the Beta request is created in the Alpha process, either the load balancer or RD is called. At the time of calling, each of these two units considers the aforementioned triple form which is called the Request Image (RI). In traditional HPC systems, RI is constant during the response by any of these two units.

Based on system's theory, the Beta request is due to the interaction of the process with an element (a process or a resource). In traditional HPC systems, a new interaction does not occur and all the interactions can be defined in the structure of the initial response. On the other hand, in distributed exascale computing systems, creation of a process or relationship between processes inside or outside of the system creates a new interaction that has not been considered in the structure of the initial response.

Based on the above discussion, it can be concluded that the dynamic and interactive nature of computational process leads to the formation of the Beta request, the RNS of which is different from that of the initial global activity. In other words, RI under the dynamic and interactive nature is changing during the execution of the load balancer or RD. In distributed exascale computing systems, the dynamic and interactive nature of computational processes leads to creation of a request that cannot be responded by the local computing system; thus it should be responded by RD. Because of the likelihood of an event with the dynamic and interactive character of distributed exascale computing systems, RI is expressed as  $RI(t)$ . To put it another way, when a dynamic and interactive event happens, the time and place limits, as well as the type of resource required, may vary. As previously stated, in distributed exascale computing systems, the influence of the dynamic and interactive character on the requests of the processes that make up the global activity can be regarded the formation of RNS or altering RI over time. When a new RNS emerges or RI varies over time, RD or, in certain situations, a load balancer should react in such a way that RD methods may be employed in distributed exascale computing systems.



### 3. Conclusions

The dynamic and participatory character of computer processes effects RD in two ways. First, the dynamic and interactive nature increases the frequency of contacting RD, implying that the functioning of RD is changing. In classical computer systems, RD is used to discover a new resource capable of responding to a process request. RD is utilized for the reaction outside

of the system's boundary and restrictions when an event with a dynamic and interactive nature occurs in computing processes. The second impact of dynamic and interactive character on RD is connected to RNS and Request Imaging (RI). If the Alpha process, in answer to Beta's request, calls

### References

- 1.E.M.Khaneghah, M.Sharifi, AMRC: an algebraic model for reconfiguration of high performance cluster computing systems at runtime. *J. Supercomput.* 67(1), pp.1–30, 2014.
- 2.M.Sharifi, E.M.Khaneghah, Tirado-Ramos, A., Mirtaheeri, S.L.: Formulating the real cost of DSM-inherent dependent parameters in HPC clusters. In: 2010 IEEE International Symposium on Parallel & Distributed Processing, Workshops and Phd Forum (IPDPSW), pp. 1–6, 2010.
- 3.A.Krekhov, J.Gruninger, R.Schlönvoigt, J.Kruger, Towards in situ visualization of extreme-scale, agent-based, worldwide disease-spreading simulations. In: ACM SIGGRAPH Asia 2015 Visualization in High Performance Computing, p.7. 2015.
- 4.P.Kumar, S.Deokar, Optimal design configuration using HOMER. In: *Advances in Systems, Control and Automation*, pp. 101–108, 2018.
- 5.E.M.Khaneghah, A.R.ShowkatAbad, R.N.Ghahroodi, Challenges of Process Migration to Support Distributed Exascale Computing Environment. In: *ACM Proceedings of the 2018 7th International Conference on Software and Computer Applications*, pp.20–24, 2018.
- 6.E.M.Khaneghah, P.Mamut, runtime flexible resource management framework in scalable distributed system based on nature of request, demand and supply and federalism, U.S. Patent No. 9,613,312. 4 Apr. 2017.
- 7.R.H.Castain, D.Solt, J.Hursey, A.Bouteiller, Pmix: Process management for exascale environments. In: *Proceedings of the 24th European MPI Users' Group Meeting*, p.14, 2017.
- 8.L.Lefe`vre, J.M.Pierson, Introduction to special issue on sustainable computing for ultrascale computing, 2018.
- 9.K.E.Mousavi, G.R.Noorabad, Sh.A.Reyhani, A mathematical multi-dimensional mechanism to improve process migration efficiency in peer-to-peer computing environments. *Cogent Eng.* 5(1), pp.1458434, 2018.
- 10.M.H.Cha, D.O.Kim, H.Y.Kim, Y.K.Kim, Adaptive metadata rebalance in exascale file system. *J. Supercomput.* 73(4), pp.1337–1359, 2017.
- 11.S.L.Mirtaheeri, S.A.Fatemi, L.Grandinetti, Adaptive load balancing dashboard in dynamic distributed systems. *Supercomput. Front. Innov.* 4(4), pp.34–49, 2017.
- 12.R.G.Abaszade, S.A.Mamedova, F.H.Agayev, S.I.Budzulyak, O.A.Kapush, M.A.Mamedova, A.M.Nabiyev, V.O.Kotsyubynsky, Synthesis and Characterization of Graphene Oxide Flakes for Transparent Thin Films, *Physics and Chemistry of Solid State*, Vol. 22, №3, pp.595-601, 2021.  
[DOI: 10.15330/pcss.22.3.595-601](https://doi.org/10.15330/pcss.22.3.595-601)
- 13.S.R.Figarova, E.M.Aliyev, R.G.Abaszade, R.I.Alekberov, V.R.Figarov, Negative Differential Resistance of Graphene Oxide/Sulphur Compound, *Journal of Nano Research Submitted*, Vol.67, pp.25-31, 2021.  
<http://dx.doi.org/10.4028/www.scientific.net/JNanoR.67.25>
- 14.R.G.Abaszade, O.A.Kapush, S.A.Mamedova, A.M.Nabiyev, S.Z.Melikova, S.I.Budzulyak, Gadolinium doping influence on the properties of carbon nanotubes, *Physics and Chemistry of Solid State*, Vol.21, №.3, pp.404-408, 2020.  
<https://doi.org/10.15330/pcss.21.3.404-408>
- 15.R.G.Abaszade, O.A.Kapush, A.M.Nabiyev, Properties of carbon nanotubes doped with gadolinium, *Journal of Optoelectronic and Biomedical Materials*, Vol.12, №.3, pp.61–65, 2020.  
[https://www.chalcogen.ro/61\\_AbaszadeRG.pdf](https://www.chalcogen.ro/61_AbaszadeRG.pdf)
- 16.R.G.Abaszade, Analysis of carbon nanotubes, *AJP Fizika*, Vol.26, №2, section: Az, pp.25-29, 2020.  
[http://www.physics.gov.az/physart/256\\_2020\\_02\\_25\\_az.pdf](http://www.physics.gov.az/physart/256_2020_02_25_az.pdf)
- 17.Kh.M.Popal, R.G.Abaszade, Research and modeling of hybrid energy systems (review), *Ecoenergetics*, №1, pp.65-69, 2022.

<http://ieeacademy.org/wp-content/uploads/2022/05/ECOENERGETS-JOURNAL-No1.-2022.pdf#page=66>

18.R.A.Namazov, R.G.Abaszade, Properties of graphene based solar panels (review), Ecoenergetics, №1, pp.3-8, 2022.

<http://ieeacademy.org/wp-content/uploads/2022/05/ECOENERGETS-JOURNAL-No1.-2022.pdf>

## Modern impulse ventilation for tunnels

T.M.Isayeva, S.Ch.Mammadov

*Azerbaijan State Oil and Industry University, Baku, Azerbaijan,*  
[tarana.isa@gmail.com](mailto:tarana.isa@gmail.com) , [mammadov.sabahaddin2000@gmail.com](mailto:mammadov.sabahaddin2000@gmail.com)

**Abstract:** Pulse ventilation, a device that enhances the flow of air in tunnels by one or more airflow vehicles. Until recently, the choice of pulse ventilation solutions limited to Sakardo nozzles and jet fans was supported by new inventions, including Banana Jet®, MoJet © and new air pulse shock absorbers. These articles provide the most up-to-date information on the alternatives mentioned, including some of their theories and applications, and their advantages and disadvantages.

**Keywords:** Pulse ventilation, Jet fans, Sakardo heads, Air jets, Dampers.

### 1. Introduction

Pulsed ventilation for tunnels suggests the application of one or more air masses to the tunnel due to the different orientation of the air mass. In fact, the energy given by a high-speed jet is given as kinetic energy to the air mass in the tunnel, which rotates at a lower speed with different efficiency distributions. There are losses when energy is transferred, because a certain percentage of air mass is lost due to friction on the faces of the tunnels and the friction of the form on any leeward objects affected by the reagent.

### 2. Experimental details

Sakardo heads (otherwise known as "Sakardo dischargers" or "pulse heads") allow airflow into the tunnel at a speed of about 30 m / s. This air jet transmits most of its impulse to the tunnel air, thus helping to direct the tunnel air in the desired direction. Marco Saccardo patented the "Advanced Method and Device for Tunnel Ventilation" in the British patent No. 2026 of 1898. This original patent describes the use of air reagents to ventilate railway tunnels.

Sakardo heads allow outside air to enter through fans located in a fan chamber at the edge of the tunnel (Figure 1). This fan chamber is conventionally mounted on a tunnel portal or shaft where air is drawn in from outside and then fed into the tunnel at a shallow angle to the longitudinal axis of the tunnel (usually at an angle of 30 degrees or less). A shallow angle is usually chosen to adapt the reagent to the tunnel axis and thus maximize the potential loss that may occur and to prevent high-speed reagents from disturbing or endangering tunnel users. In addition, care must be taken to minimize the friction losses

There are various devices for maintaining pulsed ventilation in tunnels, including the latest discoveries, including Sakardo nozzles and jet fans, as well as Banana Jet®, MoJet © and new air pulse dampers. All of these devices present issues related to their suitability to deliver the required aerodynamic power to the designer, including their capital and maintenance costs, and the power requirements of the ventilation system.

encountered by the reagent and to prevent the reagent from sticking to the tunnel surfaces. Reactive, generally "Coanda effect" is drawn to the tunnel surfaces due to - static pressure decreases due to high reactive velocity, which tends to bend the jet towards the solid surface.

The main advantages of Saccardo heads over jet fans are summarized by Bendelius (1999) as follows:

1. Reduced tunnel height;
2. The number of moving parts for storage is reduced;
3. Maintenance can be carried out without obstructing the flow of traffic;
4. Noise level in the tunnel is reduced;
5. High fan efficiency increases

The impact of air jets flowing from the tip of the Sakardo into the tunnel air can be described by the following pulse exchange equation:

$$T = mV_j \eta_j \cos(\theta) \quad (1)$$

T is the thrust from the air stream to the tunnel air [N], m is the mass air flow [kg / s],  $V_j$  is the air flow velocity [m / s],  $\eta_j$  is the installation efficiency [-],  $\theta$

is the angle between the jet and the tunnel axis. [radian].



Figure 1. Sakardo heads allow outside air to enter through fans located in a fan chamber at the edge of the tunnel

In the above equation, the efficiency of the installation  $\eta_j$  can either reduce ( $\eta_j < 1$ ) or increase the thrust force ( $\eta_j > 1$ ) depending on the function of a number of aerodynamic parameters. Irreversible processes, such as friction of the reagent along the bottom or floor of the tunnel, will reduce the efficiency of the installation, usually to a value below

the joint. However, it has been reported by Tabarra et al. (2000) that an unequal tunnel speed profile can lead to an increase in installation efficiency (referred to in the above document as the “momentum exchange coefficient”).

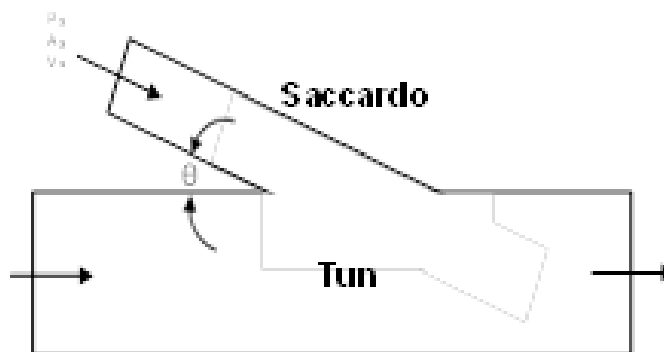

Figure 2: Impulse volume control for the Sakardo head

For a volume driven in the immediate vicinity of the Sakardo head, the steady-state longitudinal pulse equation can be written as follows (Figure 2).

$$(P_1 - P_2)A_2 = m_2V_2 - m_1V_1 - m_3V_3 \eta_j \cos(\theta) \quad (2)$$

It follows from Equation (2) that  $A_2 = A_3$ , i.e. the cross-sectional area of the tunnel does not change along the Sakardo header.

Given the mass continuity, it can be shown that the coefficient of static pressure increase  $\zeta_{12}$  in the immediate vicinity of the Saccardo head can be given as follows:

$$\zeta_{12} = \frac{P_1 - P_2}{\frac{1}{2}\rho V_2^2} = \varepsilon [2 - \varepsilon \{1 + \frac{\eta_j \cos(\theta)}{\alpha}\}] \quad (3)$$

here

$$\varepsilon = \frac{V_3 A_3}{V_2 A_2}; \quad \alpha = \frac{A_3}{A_2}$$

Equation (3) assumes that the static pressure in the downstream of the hood will increase until sufficient airflow through the nozzle is ensured.

$$\varepsilon > \frac{2}{1 + \eta_j \cos(\theta) / \alpha} \quad (4)$$

There are two main operating modes for Sakardo noses: the mode of induction of the flow of air drawn from the portal to the tunnel (generally desirable) and

the mode of rejection of the flow of air discharged from the portal (generally undesirable). Referring to the Bernoulli equation, Tabarra and others (2000) obtained a number of equations describing airflow for each mode, but these equations suffer from a number of shortcomings, including neglect of output loss ratios. If the equations were correctly developed by Tabarra and others, the single equation would apply to both flow induction and flow rejection regimes:

$$\begin{aligned} & \omega^2 \left[ \alpha^2 \left\{ 1 - \frac{1}{2} \left( K_1 + f \frac{L_1}{D_h} \right) \right\} + \alpha \eta \cos(\theta) \right] + \\ & + \omega \alpha \left[ K_1 + f \frac{L_1}{D_h} - 2 \right] - \frac{1}{2} \left[ K_1 + f \frac{L_1}{D_h} + K_2 + f \frac{L_2}{D_h} \right] = 0 \end{aligned} \quad (5)$$

Equation (5) is a quadratic equation for the velocity ratio  $\omega = V_3 / V_2$ , where  $K_1$  and  $K_2$  refer to the input or output loss coefficients in the left and right portals described in Figure 2, respectively,  $f$  is the tunnel friction coefficient ( $f = \Delta P / \{ \frac{1}{2} \rho V^2 \} / \{ L / D_h \}$ ) and  $D_h$  are the diameters of the hydraulic tunnel.

Ordinary Sakardo tips. An article in Hofer & Co (1899) and Schweizerische Bauzeitung (1899) describes the Saccardo system used for the Gotthard railway tunnel. Another early application is the 640 m long Rendsburg Tunnel, built in the 1950s.

One of the most recent requests is for the repair of the 650 m long Holmesdale tunnel on M25 (UK), which was reopened in 2007. An important factor in choosing the Sakardo system was the durability of the tunnel ventilation system without entering.

Fresh air pulse dampers.

Pischinger (2002) and Almbauer et al (2003) developed and patented a combination of fresh air injection and ventilation control. Such a system has already been implemented and consistently tested, for example. In the Katschberg tunnel, Sturm et al (2008). It consists of a damper used to inject fresh air and a blocking element in the fresh air duct that seals the rest of the fresh air duct, see Figure 3. It is possible to control the air velocity inside the tunnel with the injection head by increasing / decreasing the air volume and in some cases both the angle.

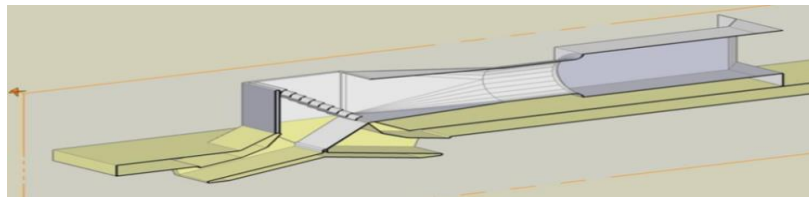

Figure 3: Fresh air pulse device: damper (left), locking element closed (center), locking element open (right)

Pruckmayer et al. (2008) describe the use of a multi-leaf damper where the opening angle at a fresh air injection point can vary from 15 ° to 140 °. In this way, the flow can be directed to the tunnel pipe in both directions.

In addition to changing the opening angle of the damper, the pulse can be changed by changing the flow rate of the supply fan.

Two-way Saccardo heads with fixed injection angle. Sakardo nozzles can be designed to work in both directions: with shock absorbers or wings to direct the airflow in one direction or another (Figure 4).



Figure 4: Sakardo head (axial cutting) that can work in both streams

Reactive fans, also called booster fans, give a boost to the air flow, but do not add or remove air from the

tunnel. The air is drawn out on the suction side of the jet and expelled at high speed on the outlet side. The average speed of the jet is in the range of 30-40 m / s.

Ordinary jet fans

Conventional jet fans blow air straight in the direction of the wheel axis and are usually aligned parallel to the tunnel axis.

The principle was promoted in the 1960s and described by Rohne (1964). According to Truckenbrodt (1980), the maximum available impulse is calculated as follows (Figure 5):

$$T_{max} = \frac{\rho}{2} \frac{A_1 A_2}{(A_1 - A_2)^2} [(2A_1 - 3A_2)v_2^2 - 2(A_1 - 2A_2)v_1 v_2 - A_2 v_1^2] \quad (6)$$

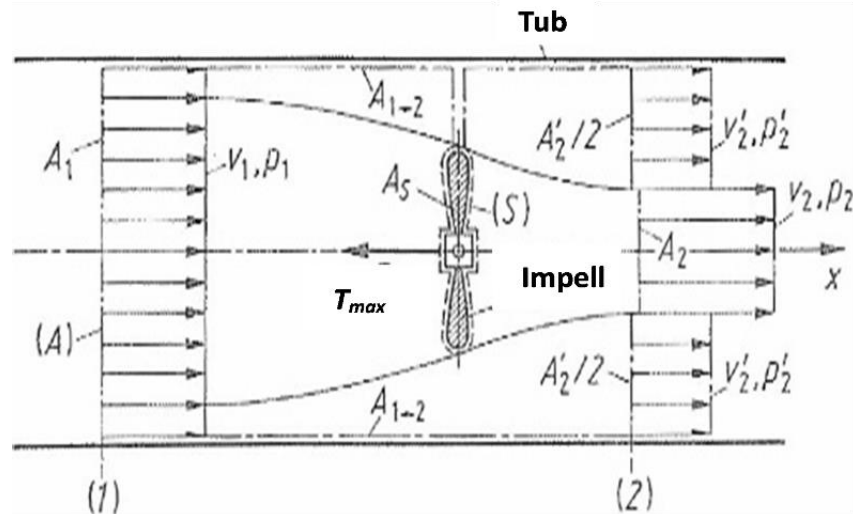

Figure 5: Tubular jet fans, nomenclature according to Trockenbrodt (1980)

For example: in a tunnel with a cross section of  $A_1$  60 with a density of  $\rho$ - 1.2 kg / m<sup>3</sup>, the tunnel gives air flow  $v_1$  2 m / s and jet speed  $v_2$  30 m / s.  $m_2$  and a jetfan outlet cross section  $A_2$  of 1 m<sup>2</sup>, maximum pressure  $T_{max}$  1017 N.

However, the following simplified model of a free-flowing wheel is usually used for practical application:

$$T_{max} = \rho A_A v_A (v_A - v_\infty) \quad (7)$$

where  $A_A$  is the intersection of the jetfan output,  $v_A$  is the average velocity of the jet, and  $v_\infty$  is the velocity in the tunnel outside the direct influence of jetfan reception and discharge. Jetfan efficiency  $\eta_f$  is conditionally used to eliminate the differences between the catalog values of thrust and reactive speed.

Jet fans with angular outlet: guide wings and inclined mufflers

As mentioned above, installation losses due to the placement of jetfans near tunnel surfaces are usually 15% to 27%.

It is useful to use guide wings or to direct the flow through the wall by tilting the outlet. Since the guide

wings at the outlet of jet fans increase losses by several percent, they are primarily useful when the jets are located near the wall. Alternatively, the muffler can be tilted away from the wall.

It is difficult to estimate the possible benefits of tilting silencers using field measurements, as the expected improvement in performance is the same as the measurement error, which is typically about 10% for single current measurements. However, two measurement campaigns were conducted in areas called Banana Jets. In both cases, the jet fans are adapted by inserting a triangular fitting between the muffler and the wheel block to mimic ordinary, straight jet fans. However, this means that the output of an ordinary jet was closer to the wall than the Banana Jet configuration, resulting in higher installation losses for a straight jet.

The two jet fan configurations show a comparison of speed profiles at different downstream positions. First, it is noted that at distances of 60 m to 120 m from the jet stream, the velocity profile is uniform, ie there is no visible effect of the jet. Second, the speed profile measured close to the jet is more accurate than a straight jet for the Banana Jet.

In the first measurement campaign (Pospisil et al., 2003), the measurement error was  $\pm 19\%$  when comparing the two flow measurements. Taking into account the accuracy of the measurements, it was concluded that the thrust of jetfans with inclined mufflers is between 23% and 94% lower than that of ordinary jetfans.

In the second measurement campaign (Marti and Brandt, 2004), improvements in measurement techniques reduced the measurement error by  $\pm 12\%$  compared to the two flow areas. Here the jetfans were installed in the corners of the rectangular tunnel section. The inclined mufflers were aimed at the middle of the tunnel. It was concluded that the impulse power of the Banana Jet is between 11% and 21% higher than that of ordinary straight jetfans.

It seems that by tilting the muffler by about  $7^\circ$ , almost uniform installation efficiency can be achieved. This corresponds to a higher loss of power, usually between 15% and 25%, compared to conventional flat jets.

In our experience, with Banana Jets, there is a risk that the reagent will stick to the floor of the tunnel

and advance like a "wall jet". The air velocity above the wall flow may be less than the critical velocity for smoke control, which may result in the formation of a back layer of local smoke. This problem can be solved at the design stage of the project.

Convergent nozzle jet fans (MoJet ©) MoJet (Momentum Jet) is the latest innovation to combine higher pressure like Saccardo nozzles with higher installation efficiency, such as Banana Jets (Tarada, 2008). This is achieved by using convergent nozzles on one or both sides of the jet fans. Nozzles, which can also act as a muffler, increase the thrust of an ordinary jet by accelerating the flow rate during discharge from the jet. As long as the mass flow through the jet is not significantly reduced due to the additional pressure drop on the hood, the enhanced aerodynamic power will be achieved in accordance with Equation 7.

The same headers also direct the flow to the center line of the tunnel, thus achieving the installation efficiency ( $\eta_i$ ) of the adjacent unit. Figure 6 shows one-way MoJets installed near the tunnel portal and two-way MoJets installed inside the tunnel.

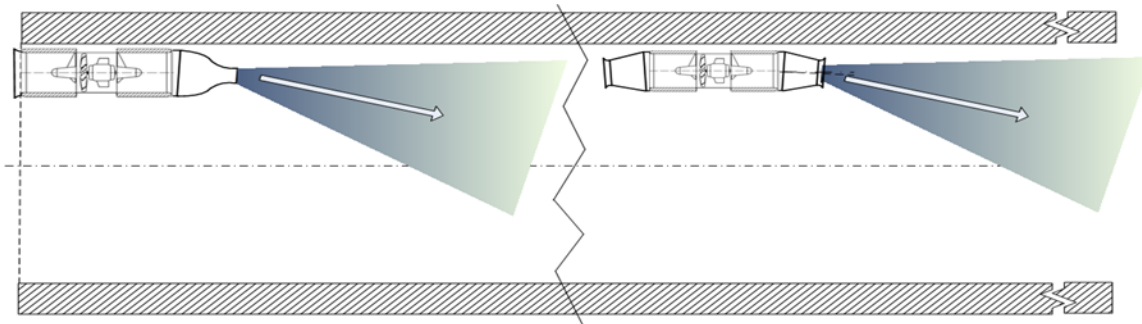

Figure 7: Fan operation characteristic with MoJet

The effect of mounting the convergent head on the jetfan to the operating point of the fan is illustrated in Figure 7. This graph shows that When the nozzle is installed on the fan, the volumetric flow rate drops from  $V_1$  to  $V_2$ . However,  $V_2$  is still larger than  $V'_1$ , where  $V'_1$  is on a fixed power line from  $V_1$ . Thus, as long as the new operating point is below the fan stop line, it is likely that the installation of a convergent hood will increase the pressure produced by the fan. This is because when the modified operating point is compared to the original operating point, the fan pressure and volumetric flow rate characteristics for a given speed and blade configuration are generally more steep than the constant force relationship between pressure and volumetric flow rate.

Compared to the thrust created by a noseless jetfan, an increase in the thrust of a ventilating device with a hood is achieved when there is enough "steepness" to ensure the characteristics of the fan.

For one-way MoJet:

$$\frac{\partial P}{\partial V} > \frac{2\rho v_A^2}{v} \quad (10)$$

For two-way MoJet:

$$-\frac{\partial P}{\partial V} > \frac{2(1+K_{in})\rho v_A^2}{v} \quad (11)$$

Here  $V$  is the volume of air passing through the ventilation device [ $m^3 / s$ ],  $K_{in}$  is the coefficient of inlet loss to the hood ( $\approx 0.5 - 0.6$ ).

A number of simplifications have been made in obtaining Equations 10 and 11 above, including:

- It is assumed that the pressure drop through the nozzles predominates over the overall fan pressure drop;
- The jet speed  $V_j$  is assumed to be much higher than the tunnel air velocity  $W$ ;
- The fan characteristic (curve  $P - V$ ) is assumed to be linear in the corresponding range.
- The wall friction inside the hoods is assumed to be small.

Figure 12 shows the effect of the ratio of the nose area on the traction force of a 1.12m diameter jet, and Figure 13 shows the change in the absorbed force for

the same jet. The following information was used for this purpose:

1. Selected one-way jetfan guide winged Fläkt Woods 112JM / 40/4/9/24.
2. Double directional jetfan selected guide wingless Fläkt Woods 112JM / 40/4/9/26 TS.

The figures in these examples show that longitudinal thrust can be increased by 20% in one-way and up to 12% in two-way. Power demand increases approximately linearly with increasing nasal area ratio, for example, a 27% increase in absorbed power will be required to obtain a peak two-way thrust.

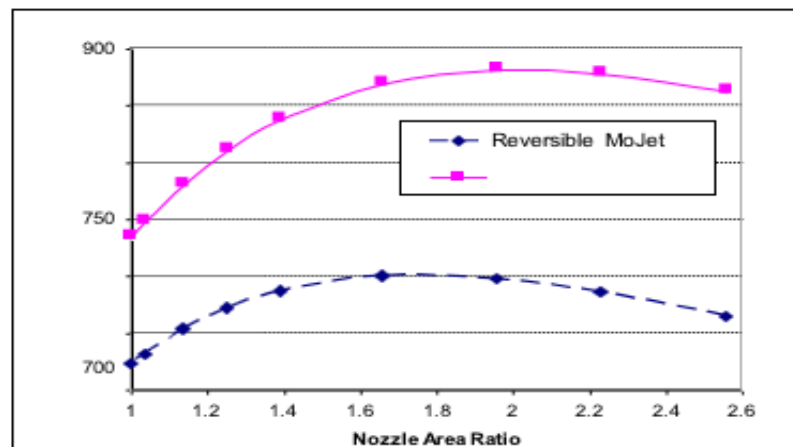
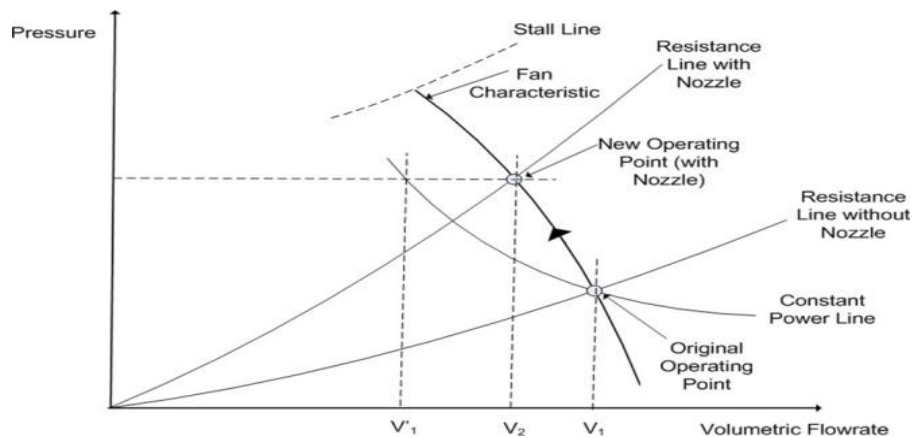

Figure 12: Impact of Head Area Ratio on Loss of a 1.12 m Diameter Jet Fan (Crouzier, after 2008)



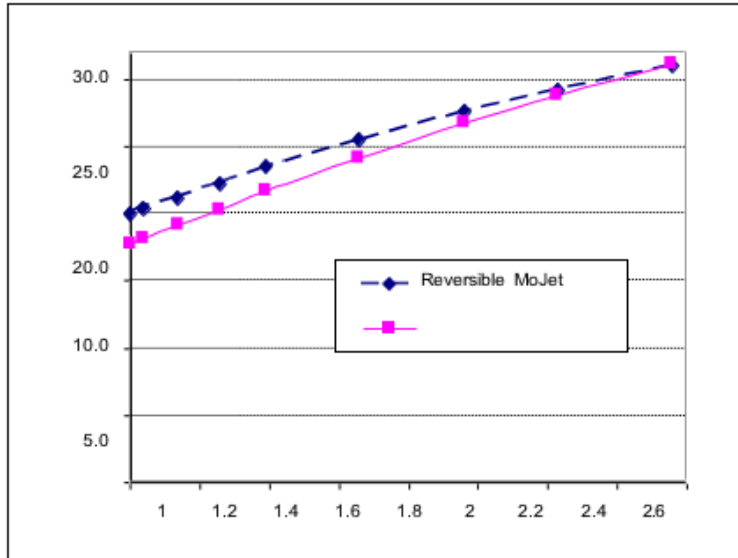

Figure 13: Effect of Nozzle Area Ratio on 1.12 m Diameter Jetfan Power (After Crossier, 2008)

The application of graphene-based nanomaterials is one of the latest achievements of science [1-7].

### 3. Conclusions

Choosing impulse-ventilation types Designers now have a comprehensive range of tools available to them and have the right to choose products that meet their criteria.

The Sakardo complex is often built close to the portals. In terms of total power, their thrust is also less than that of conventional jet fans in general. However, they are relatively easy to control due to the possibility of access to the sensitive surfaces of the units from an alternative entrance from the transport point. This allows the ventilation complex and the end of the tunnel to be equipped with better accessibility. Also, no other tunnel area is required to cover the jet fans, which in turn leads to a reduction in civil society costs.

In the existing tunnels with a semi-transverse fresh air fan complex, fresh air pulse dampers are installed at low overhead costs.

By folding the jet silencers from the walls of the tunnels in other directions, the installation

convenience is obtained not far from the union. Otherwise, for jet fans not far from the surface of the tunnel wall, but not in place, the minimum installation utility between 73% (jet fan at the corner of the rectangular tunnel) and 85% (jet fan on the surface of the tunnel wall) is normally expected. At the same time, the inclination of the muffler increases the overall dimensions of the jet fan. It should be noted that this can manipulate the wishes of the tunnel area. For jet fans on the surface of the tunnel wall, which have no place due to the inclination of the noise, the use of curved arms at their outlet increases the overall efficiency.

To expand the offer and increase the efficiency of the installation, the production and operation of jet fan silencers as a convergent hood has been proposed. This significantly reduces the number of jet fans required in the tunnel, but more power is likely to be required for each jet fan.

### References

1.R.A.Almbauer, P.J.Sturm, D.Öttl, M.Bacher, A new method for influencing airflow in transversely ventilated road tunnels during a fire. In: Proceedings of the Tunnel Ventilation Conference, BHR Group 2003.

2.A.G.Bendelius, Tunnel Ventilation' in 'Tunnel Engineering Handbook, ed. Bickel, J.O., Kuesel, T.R and King, E.H., 2nd ed., Chapman & Hall, 1999.

3.E.Jacques, P.Wauters, Improving the ventilation efficiency of jefans in longitudinally ventilated

rectangular ducts, Proceedings of the 8th US Mine Ventilation Symposium, ISBN 1-887009-04-3, University of Missouri-Rolla, pp.503-507, 1999.

4.B.Kenrick, Commissioning of the Holmesdale Tunnel Saccardo System, UK Road Tunnel Operators Forum, Fire Service College, March, 2008.

5.M.Marti, R.Brandt, Strömungsmessung, Tunnel de Collembe, HBI report 03-100-02, 23 February, 2004.

6.Sturm, P.J., Bacher, M., Brandt, R. (2008), "The evolving needs of tunnel ventilation in a changing world", 4th International Conference on Tunnel Safety and Ventilation, 2008, Graz, ISBN: 978-3-85125-008-4

7.PIARC (2008), Road Tunnels: Operational Strategies for Emergency Ventilation, Technical Committee C3.3 Tunnel Operations, Working Group № 6 Ventilation and Fire Control, World Road Association.

8.R.G.Abaszade, S.A.Mamedova, F.H.Agayev, S.I.Budzulyak, O.A.Kapush, M.A.Mamedova, A.M.Nabiyev, V.O.Kotsyubynsky, Synthesis and Characterization of Graphene Oxide Flakes for Transparent Thin Films, Physics and Chemistry of Solid State, Vol.22, №3, pp. 595-601, 2021.

[DOI: 10.15330/pcss.22.3.595-601](https://doi.org/10.15330/pcss.22.3.595-601)

9.S.R.Figarova, E.M.Aliyev, R.G.Abaszade, R.I.Alekberov, V.R.Figarov, Negative Differential Resistance of Graphene Oxide/Sulphur Compound,

Journal of Nano Research Submitted, Vol.67, pp.25-31, 2021.

<http://dx.doi.org/10.4028/www.scientific.net/JNanoR.67.25>

10.R.G.Abaszade, O.A.Kapush, S.A.Mamedova, A.M.Nabiyev, S.Z.Melikova, S.I.Budzulyak, Gadolinium doping influence on the properties of carbon nanotubes, Physics and Chemistry of Solid State, Vol. 21, №3, pp.404-408, 2020.

<https://doi.org/10.15330/pcss.21.3.404-408>

11.R.G.Abaszade, O.A.Kapush, A.M.Nabiyev, Properties of carbon nanotubes doped with gadolinium, Journal of Optoelectronic and Biomedical Materials, Vol.12, №3, pp.61-65, 2020.

[https://www.chalcogen.ro/61\\_AbaszadeRG.pdf](https://www.chalcogen.ro/61_AbaszadeRG.pdf)

12.R.G.Abaszade, Analysis of carbon nanotubes, AJP Fizika, Vol.26, №2, section: Az, pp.25-29, 2020.

[http://www.physics.gov.az/physart/256\\_2020\\_02\\_25\\_az.pdf](http://www.physics.gov.az/physart/256_2020_02_25_az.pdf)

13.Kh.M.Popal, R.G.Abaszade, Research and modeling of hybrid energy systems (review), Ecoenergetics, №1, pp.65-69, 2022.

<http://ieeacademy.org/wp-content/uploads/2022/05/ECOENERGETS-JOURNAL-No1.-2022.pdf#page=66>

14.R.A.Namazov, R.G.Abaszade, Properties of graphene based solar panels (review), Ecoenergetics, №1, pp.3-8, 2022.

<http://ieeacademy.org/wp-content/uploads/2022/05/ECOENERGETS-JOURNAL-No1.-2022.pdf>

## Development of electromechanic power control system

M.Kazim, L. Aliyeva

Azerbaijan State Oil and Industry University, Baku, Azerbaijan,  
[Murad.kazim.eng@gmail.com](mailto:Murad.kazim.eng@gmail.com) , [letife\\_elxan@mail.ru](mailto:letife_elxan@mail.ru)

**Abstract:** Although there is little work on this topic, it is quite important and broad in itself. Before entering our topic, we must first know certain concepts, the basics of the material we will cover today. we will briefly consider the general paragraph. Before explaining electromechanical energy converters, we need to know what the concept of electromechanics is in order to form an initial idea in our brain. Electromechanics is a controlled mechanical process or device driven by electricity: a converter that converts electrical energy into mechanical energy. At present, we have some idea about the concept of electromechanics (taking into account our previous knowledge). Now we can talk about electromechanical energy converters. The conversion of electromechanical energy is the conversion of mechanical energy. the process of converting energy into electrical energy (generator) or vice versa (motor).

**Keywords:** Electromechanical, Electromechanical energy converter, Power flow, Electric.

### 1. Introduction

Electric machines are divided into two types: generators and motors. Generators convert mechanical energy into electrical energy. Engines convert electrical energy into mechanical energy. There are basically three groups of electric cars.

1. DC machines;
2. Asynchronous machines;
3. Synchronous machines.

An electromechanical energy converter is a device that converts electrical energy into mechanical energy or mechanical energy into electrical energy. The conversion or conversion of electromechanical energy

occurs through a magnetic field or electric field, but the vast majority of practical converters use a magnetic field as a connecting medium between electrical and mechanical systems because the electrical field capacity of a magnetic field is higher than that of an electric field.

Electromechanical power converters are divided into 2 types: Rough moving devices - such as electric motors or generators; Increasing motion devices - Microphones, speakers, electromagnetic relays and electrical measuring devices, etc.

The application of modern materials goes beyond the possibilities [1-12].

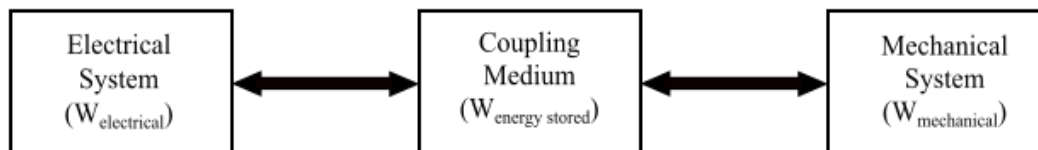

Figure 1. Electromechanical energy connection.

### 2. Experimental details

When electromechanical energy is converted from electrical to mechanical energy, it is known as an inverter motor. However, when a conversion from mechanical energy to electrical energy takes place, the device is recognized as a generator.

- When a conductor moves in a magnetic field, an EMF (Electromotive force or Electromotor force) is induced in the conductor.
- When a current-carrying conductor is placed in a magnetic field, a mechanical forces acts on the conductor.

The above-mentioned process often occurs spontaneously in the process of converting energy from electrical to mechanical or vice versa.

The operation of electric machines finds its existence in the fact that mechanical devices require a large amount of energy to support and support mechanical power, and people can create electrical methods (including devices, etc.) that can transmit a large amount of this energy. The most common of these systems is probably the electromechanical converter. Accept the power properties of a given mechanical load. Given the power properties of a given mechanical load. If we accept the existence of a large number of random mechanical loads, this becomes a logical consequence that not all of them can be transformed.

Electricity is obtained from a system that produces energy, which is converted from a non-electrical form to an electrical form. At this stage, power flow is likely to be controlled (or not). and this station is fed by a large number of random loads, which in turn leads to the conclusion that this type of power control is not possible. Power loss during transmission can be found in the electric transmission system.

Due to the centralized nature of most of these systems, this type of energy flow control is only possible if applied locally.

The energy is then transferred to an electromechanical converter and converted into mechanical energy with some loss. This is a real indication that the power flow is likely to be controlled. The extent to which this is possible will be investigated later. Converted power now passes mechanically through a mechanical transmission system - with a loss of transmission to the mechanical load. Changing the loss parameters of this transmission system offers the last chance to regulate the energy flow to the load, as can be seen from the use of sliding couplings (electrical and mechanical). Under these conditions, the electromechanical energy converter has a constant total load.

$$dW_f = \frac{\partial W_f}{\partial \lambda} d\lambda + \frac{\partial W_f}{\partial x} dx \quad (2.1)$$

$$F_f dx = - \frac{\partial W_f}{\partial x} dx + \left( i - \frac{\partial W_f}{\partial \lambda} \right) d\lambda \quad (2.2)$$

$$i = \frac{\partial W_f(\lambda, x)}{\delta \lambda} \quad (2.3)$$

$$F_f = - \frac{\partial W_f(\lambda, x)}{\partial \lambda} \quad (2.4)$$

In order to study the main groups of control methods for controlling the power flow in the process of electromechanical energy conversion, it is necessary to consider a general converter. It has a stationary "stator" (s) and a rotating "rotor" (r) rotor. The characteristics of the magnetically active material are as follows:

- a. There is no magnetic hysteresis of the material
- b. The material has infinite electrical resistance.

There are two main types of converters that will be available during the conversion process to further explore the principles of power management: synchronous and asynchronous. Definitions move away from classical definitions in this area. Synchronous electromechanical inverters - the inverters that connect both stator and rotor windings are fed by currents with frequencies determined by external sources, have a set of discrete values according to the mechanical speed relay. Synchronous machines are made with great power. A three-phase winding is placed in the stator of the engine. When this circuit is connected to a three-phase alternating current network, a rotating magnetic field will be created, the number of cycles per minute as follows:

$$n_1 = 60f/P$$

The rotating magnetic field created by the current of the stator waves moves the poles of the rotor behind it, and an impact wave is placed, which is connected to a direct current network. The impact current creates a magnetic flux of the poles. The speed of the synchronous motor is completely constant. In this case, the rotor rotates synchronously, ie at a speed equal to the speed of rotation of the stator field. One of the advantages of synchronous motors is that they are less sensitive to voltage fluctuations in the supply network than asynchronous motors. In asynchronous motors, the torque is proportional to the square of the voltage. In synchronous motors, the torque is proportional to the mains voltage. The main advantage of a synchronous motor is that the motor can be a capacity loader for the network. As a result of the effect of the stator magnetic field on the magnetized rotor, the torque of the synchronous motor is created. When the stator winding is connected to the mains, a rotating magnetic field is created, as it is not possible to start the synchronous motor by connecting it to the mains. The engine does not generate torque. At this point, the rotor is motionless.

The magnetic fields of the stator and rotor do not interact. Thus, to start the engine, the rotor must be rotated synchronously. Currently, the so-called "asynchronous start" method is more commonly used to start synchronous motors. For small-power synchronous motors, there is no need to reduce the voltage first in order to start asynchronously. Recently, the start-up of synchronous motors has been further simplified. The motor's impeller is always connected to the actuator. At start-up, at small values of the number of cycles, the exciter located on the shaft of the synchronous motor does not yet generate a constant current, and the motor increases its speed in asynchronous mode. At values close to synchronous, the DC machine is affected and conducts an impressive current from the motor rotor. The poles of the rotor are magnetized, and when the poles of the stator field meet the different names of the rotor in space, they stick together and the motor synchronizes. The starting period of a synchronous motor is characterized by two moments. The first of these can be called the starting torque, or the starting torque, and the second can be called the input torque. The starting torque is the torque generated by the engine at the first start-up, ie when the rotor is at rest, and the starting torque is when the rotor speed is very close to synchronous speed. Since the synchronous motor operates as a short-circuited asynchronous motor between these two modes, its torque will also change with the law that the asynchronous torque changes between the values of these two limits. When it is necessary to stop the synchronous motor, it is not allowed to open the key suddenly. In this case, first reduce the exposure current to the minimum value of the stator current, and then open the stator circuit from the external circuit. The essence of this method is as follows. At the pole ends of the synchronous motor is placed a starting loop, which is made in the form of a "squirrel wheel" and as a short-circuited rotor of the rotor of an asynchronous machine. The stator windings are connected to a three-phase network and the motor is started as in an asynchronous motor with a short-circuited rotor. If we short-circuit the impact ring, the loaded engine will rotate at about half the synchronous speed and no synchronization will take place. The ability to operate from the mains by using a pre-current allows the synchronous machine to be used as a compensator. The synchronous motor, which operates without load and is designed to increase the  $\cos\phi$ , is a compensator. Thus, the compensator becomes a reactive power generator. The compensator is very different in structure from a

synchronous motor. As the compensator is not subject to mechanical load, its shaft and rotor are lightweight, and the air gap is smaller than that of the engine. The main disadvantage of synchronous motors is that they require both alternating and constant current sources. The fact that a synchronous motor requires a constant current source to power the impact arc results in inefficient operation of the motor at low power. Therefore, synchronous motors powered by direct current at low power are not used. Jet synchronous motors are widely used when power is low and constant speed is required (in automation and telemechanics). The occurrence of torque in such an engine can be explained by the fact that when the magnetic flux increases, the magnetic lines pull the rotor protrusion, trying to close it in a path with low magnetic resistance. When the magnetic flux decreases, the rotor moves inertially, and then when the magnetic flux increases, the next tooth pole is pulled. Asynchronous electromechanical converters - inverters are a type of converter in which the rotor or stator frequency is determined by an external source and at least the frequency of the current in the other member is determined only by electromagnetic induction associated with the mechanical speed of the relay. An alternating current electric machine that converts electrical and mechanical energy into each other through a rotating magnetic field is called an asynchronous machine. The magnetic field is generated by an alternating current coming from the network. An important feature of an asynchronous machine is that its rotating magnetic field and rotor rotate at different speeds during operation. In electric motor mode, the speed of the rotor is less than the speed of the magnetic field, and in generator mode it is greater. That is why such machines are called asynchronous machines. In both generator and motor mode, the rotor speed varies depending on the load. Due to their simplicity of construction, low cost and reliability in operation, asynchronous machines are widely used in various industrial and agricultural installations as electric motors. An asynchronous machine consists of a stator (stationary part) and a rotor (rotating part). Asynchronous machines have such a structure that when they are connected to the mains, a rotating magnetic flux is generated in the stator. The rotor of the machine is driven by a rotating magnetic flux, but the speed of the rotor lags behind the speed of the magnetic flux. The uneven speed has led to the naming of these machines "Asynchronous".

An asynchronous machine is called an alternating current machine and its structure is shown in Figure.2

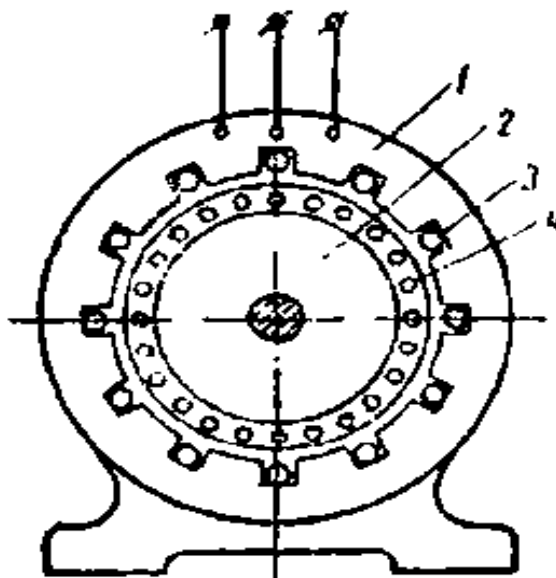

Figure.2. The structure of an asynchronous motor  
1-stator; 2-rotor; 3-stator winding; 4-rotor winding

This device consists of 4 parts; stator, rotor, stator winding, rotor winding. The stator lining is assembled from 0.30 and 0.5 mm thick steel plates. The boards are slot stamped and insulated with lacquer or thin paper to reduce the loss of vortex currents. The plates are assembled and fastened to the engine body in a separate package. The side panels on which the bearings on which the rotor shaft rests are also attached to the body. In the longitudinal slots of the stator, they are connected to each other and place the wires of the winding, forming a three-phase system. There are six clamps on the machine board to connect the start and end of the phase windings. To connect the stator windings to a three-phase network, they can be combined star and delta. This allows the motor to be connected to a network with two different line voltages. The dashboard of the car shows both voltages calculated by the motor, ie 220 / 127v, or 380/220v. The stator winding is connected in a triangle for the low voltage indicated on the board, and a star for the high voltage. The inside of the rotor is also assembled from 0.5 mm thick steel plates insulated with lacquer or thin paper to reduce the loss of vortex currents. These boards are hollow stamped and assembled in a package. At present, asynchronous motors are mainly made with short-circuited rotors, but are used in very powerful motors and in special cases in the rotor phase winding. There is an air gap between the stator

and the rotor; The size of the gearbox greatly affects the performance of the engine. Simple design of asynchronous motor, easy maintenance, low cost, etc. In addition to its positive properties, it also has a number of disadvantages. The most important disadvantage of an induction motor is that the power factor ( $\cos\varphi$ ) is relatively low. For the first time, a three-phase asynchronous motor is more widespread than the electric motors designed by MO Dolivo-Dobrovolsky. The asynchronous motor has the property of turning. The job of an asynchronous machine is to convert electrical energy into mechanical energy in engine mode. The operation of an alternating current machine is based on the use of each multi-phase rotating magnetic field. A multiphase alternating current creates a rotating magnetic field with the number of cycles per minute,  $n = (60 \cdot f_1)/p$ .

If the speed of rotation of the magnetic field is not equal to the speed of the rotor, ( $n_2 \neq n_1$ ) it is called asynchronous speed.

When the rotational speed of the rotor is not equal to the rotational speed of the magnetic field, that is, in an asynchronous motor, the work process can only proceed at an asynchronous speed.

When the engine is running, the rotor speed is always reduced ( $n_2 < n_1$ ). The speed of rotation of the rotor is always equal to the speed of rotation of the

magnetic field of the stator. This is how asynchronous machines differ from synchronous machines.

If the rotor winding is short-circuited, current will flow through it under the influence of the induced e.h.q. The rotating magnetic field of the stator intersects the wires of the rotor winding, where e.h.q. induced. If the current in the rotor winding interacts with the rotating magnetic field of the stator winding, a torque is created and the rotor begins to rotate. The relative delay of the rotor and the stator from the rotating magnetic field is called the S-shift. Sliding, rotating rotor of the magnetic field of the stator In relation to  $n_1$ , the number of cycles is the ratio of the stator field to the number of cycles in space, ie:

$$S = n_s / n_1 = (n_1 - n_2) / n_1$$

This formula allows you to define a shift in relative units. The landslide can also be expressed as a percentage:

$$S\% = (n_1 - n_2) / n_1 \cdot 100\%$$

If the rotor is stationary ( $n_2 = 0$ ), the slip is equal to one or 100%. If the rotor rotates at the same speed ( $n_2 = n_1$ ), the slip is zero. This means that the higher the speed of rotation of the rotor, the less slip is obtained, ie:

$$n_s = n_1 - n_2 \text{ period / min}$$

slides relative to the rotor.

Asynchronous motor operation is less slippery. In modern asynchronous motors, the speed of rotation of the rotor differs very little from the speed of rotation of the magnetic field of the stator. In no-load operation, this zero can be taken as equal.

The speed of rotation of the rotor can be determined:

$$n_2 = n_1 - n_s = n_1 (1 - S) = (60f_1) / p (1 - S)$$

When the torque balance is reached, ie the engine torque ( $M_{fir}$ ) is equal to the braking torque ( $M_{torm}$ ). Generated by the mechanical energy receiver, for example, the lathe cross section on the engine shaft, the engine will run stably. So we can write that

$$M_{fir} = M_{torm}$$

The number of cycles of the rotor  $n_2$  and a certain slip  $S$  correspond to any loading of the machine.

Inspired by the above and the machine theory generalized in this survey, switching machines can be included in the group of synchronous converters by considering this machine as a synchronous machine with a frequency converter. effects are not included. The study of designed controlled electric drives has evolved over the years and may have evolved. Historical electrical engineering practice has been divided into alternative and direct voltage supply

systems, including normal machine types, for better adaptation.

The theory of electromechanical energy conversion is the cornerstone of the analysis of electromechanical motion devices. - The theory allows to express such properties as electromagnetic force or torque, currents and displacement of the mechanical system with device variables. If the conductor can move freely in the direction of the magnetic force, the magnetic field helps it to convert electrical energy into mechanical energy. This is the principle of operation of virtually all electric motors.

An attempt was made to develop a method for calculating the characteristics of switched electric machines. Section 18 of Electrical Engineering places great emphasis on knowledge of the harmonic components of non-sinusoidal voltages and currents. This applies to the design of electric machines and other equipment and the provision of the system mainly from the national electricity grid, harmonic currents cannot be included accidentally. When machine-electronic systems operate at higher power levels, the harmonic components of voltages and currents can cause serious interactions with other electrical equipment and even cause the system itself to malfunction.

In these cases, it is more important to know the harmonic components in advance. The above considerations resulted in the fact that the method of theoretical analysis is essentially the Fourier method. Calculations are difficult because differential equations contain coefficients that change periodically, even under constant speed limits. However, all these problems are expected to be resolved satisfactorily.

Theoretical features of power electronic circuits found in machine-electronic systems also need systematic classification and research. While all aspects previously explored are common, there are limitations. It is possible to prepare a classification for the main groups of power electronic circuits. However, the diversity of these schemes precludes a comprehensive study of as many different options as possible for different methods of driving electric machines. By combining knowledge of the behavior of a switched electromechanical converter and power electronic circuits, it was possible to calculate the characteristics of the systems studied by applying appropriate constraints.

## Energy Conversion Process

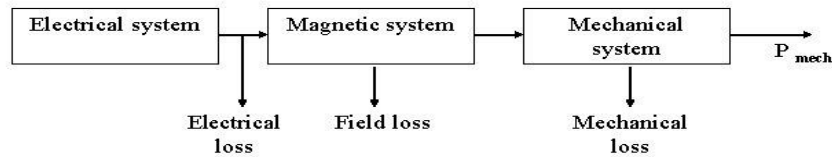

The energy transfer equation is as follows:

$$\left( \begin{matrix} \text{Electrical} \\ \text{energy input} \\ \text{from sources} \end{matrix} \right) = \left( \begin{matrix} \text{Mechanical} \\ \text{energy} \\ \text{output} \end{matrix} \right) + \left( \begin{matrix} \text{Increase in} \\ \text{stored energy in} \\ \text{magnetic field} \end{matrix} \right) + \left( \begin{matrix} \text{Energy} \\ \text{losses} \end{matrix} \right)$$

*Figure 3. Energy conversion process*

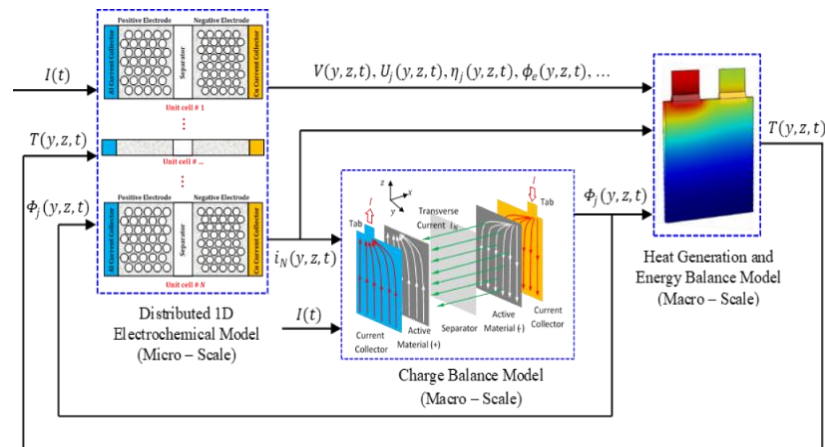

*Figure 4. Charge balace model*

### 3. Conclusions

This article examines electromechanical converters and their control and electromechanical energy conversion on the principles of energy flow. In order to develop a theory for these types of systems, an attempt is made to make the subject as general as possible. According to the topic, a group of general systems is selected for additional theoretical research. This article seeks to show what the scale of electromechanical energy converter management is and how it has evolved over the years, as it is not evaluated at all. Thus, it examines the methods of controlling the flow of energy associated with the process of electromechanical energy conversion,

provides an overview of the methods of controlling this process, looks at the history of machine electronics and concludes with some information on the scope of the topic.

Systematic electromechanical energy conversion process for electronic control systems is based on the principles of power flow. The systems are divided into three groups, which differ fundamentally from each other (group I, group II, group III). It is shown that some machine-electronic systems with a more complex structure are in fact hybrid systems composed of different groups of elements.



The interaction between the non-ideal characteristics of power-electron circuits and the electromechanical transducer, or vice versa, was not actually expected in the idealized theoretical idea, but can be expected to occur in systems of practical idea. Since

no systematic knowledge of these effects is currently available, it appears to be an extremely valuable topic for future unifying studies on the electronic control of the electromechanical energy conversion process.

## References

1. Electronic Control of Electromechanical Energy Conversion by JACOBUS DANIEL VANWYK, Rotterdam, 1969.
2. JavaTPoint.com. Electromechanical Energy conversion principles, 2021
3. Tutorialspoint.com. Principle of Electromechanical energy conversion, 2021
4. R.G. Abaszade, S.A. Mamedova, F.H. Agayev, S.I. Budzulyak, O.A. Kapush, M.A. Mamedova, A.M. Nabiyev, V.O. Kotsyubynsky, Synthesis and Characterization of Graphene Oxide Flakes for Transparent Thin Films, *Physics and Chemistry of Solid State*, Vol.22, №3, pp.595-601, 2021.  
[DOI: 10.15330/pcss.22.3.595-601](https://doi.org/10.15330/pcss.22.3.595-601)
5. S.R. Figarova, E.M. Aliyev, R.G. Abaszade, R.I. Alekberov, V.R. Figarov, Negative Differential Resistance of Graphene Oxide/Sulphur Compound, *Journal of Nano Research Submitted*, Vol. 67, pp. 25-31, 2021.  
<http://dx.doi.org/10.4028/www.scientific.net/JNanoR.67.25>
6. R.G. Abaszade, O.A. Kapush, S.A. Mamedova, A.M. Nabiyev, S.Z. Melikova, S.I. Budzulyak, Gadolinium doping influence on the properties of carbon nanotubes, *Physics and Chemistry of Solid State*, Vol. 21, №3, pp.404-408, 2020.  
<https://doi.org/10.15330/pcss.21.3.404-408>
7. R.G. Abaszade, O.A. Kapush, A.M. Nabiyev, Properties of carbon nanotubes doped with gadolinium, *Journal of Optoelectronic and Biomedical Materials*, Vol.12, №3, pp.61-65, 2020.  
[https://www.chalcogen.ro/61\\_AbaszadeRG.pdf](https://www.chalcogen.ro/61_AbaszadeRG.pdf)
8. R.G. Abaszade, Analysis of carbon nanotubes, *AJP Fizika*, Vol.26, №2, section: Az, pp.25-29, 2020.  
[http://www.physics.gov.az/physart/256\\_2020\\_02\\_25\\_az.pdf](http://www.physics.gov.az/physart/256_2020_02_25_az.pdf)
9. Kh.M. Popal, R.G. Abaszade, Research and modeling of hybrid energy systems (review), *Ecoenergetics*, №1, pp.65-69, 2022.  
<http://ieeacademy.org/wp-content/uploads/2022/05/ECOENERGETS-JOURNAL-No1.-2022.pdf#page=66>
10. R.A. Namazov, R.G. Abaszade, Properties of graphene based solar panels (review), *Ecoenergetics*, №1, pp.3-8, 2022.  
<http://ieeacademy.org/wp-content/uploads/2022/05/ECOENERGETS-JOURNAL-No1.-2022.pdf>
11. O.A. Kapush, I.O. Mazarchuk, L.I. Trishchuk, V.Y. Morozovska, S.D. Boruk, S.I. Budzulyak, D.V. Korbutyak, B.N. Kulchitsky, O.G. Kosinov, R.G. Abaszade, Influence of the nature of the dispersion medium on the optical properties of CdTe nanocrystals during sedimentation deposition, *Chernivtsi University Scientific Herald, Chemistry* (819), pp.7-11, 2019.  
<https://doi.org/10.31861/chem-2019-819-01>
12. R.G. Abaszade, S.A. Mamedova, F.H. Agayev, S.I. Budzulyak, O.A. Kapush, M.A. Mamedova, A.M. Nabiyev, V.O. Kotsyubynsky, Synthesis and Characterization of Graphene Oxide Flakes for Transparent Thin Films, *Physics and Chemistry of Solid State*, Vol.22, №.3, pp.595-601, 2021.  
[DOI: 10.15330/pcss.22.3.595-601](https://doi.org/10.15330/pcss.22.3.595-601)

## **Modeling and simulation of working agent distribution between wells**

**S.I.Yusifov, S.A.Cabbarov**

*Azerbaijan State Oil and Industry University, Baku, Azerbaijan,  
[salahaddin.yusifov@asoiu.edu.az](mailto:salahaddin.yusifov@asoiu.edu.az) , [suvahilcabbarov@gmail.com](mailto:suvahilcabbarov@gmail.com)*

**Abstract:** The object of study of which is oil wells operating in a gas-lift way, based on the analysis of existing control algorithms and models of gas-lift wells, the advantages and disadvantages of controls, equipment and systems, an algorithm and models of optimal distribution with high efficiency, accuracy, as well as reliability developed, the functional structure of the corresponding control system, a scheme for connecting sensors and actuators is chosen, an algorithm for solving a multilevel problem of optimal distribution is proposed, models and an algorithm for local, one and two-level optimal control are developed. The problems of identification of mathematical models of wells are analyzed, the requirements for identification and the mathematical apparatus necessary for its implementation are determined, the objective function of the optimal distribution problem for each level and the corresponding constraint conditions are determined.

**Keywords:** Gas lift oil extraction, Well, Working agent, Automation, Pressure, Workplace, Algorithm, Controller, Operator, Actuator.

### **1.Introduction**

One of the important methods used in oil production is gas lift oil extraction. The main components of the gas lift complex are the produced stratum, wells, wellhead oil pipelines, separators, gas compressors and gas injection lines to the wells. This necessitates the management of the complex as a single system, interconnected. Management of the oil extraction process, which is a complex technological process, begins with the optimal management of its individual nodes and elements and the definition of the relationship between the equipment and the object (well) [1].

As a controlled object, gas lift wells have some unique features. Gas lift wells differ in design and operating characteristics. The operating mode and design parameters may include: the depth at which the filter is located, the amount of fluid discharged from the well, the volume of the working agent injected into the well, the wellhead and bottomhole pressures, and so on. As the parameters of wells connected to a group gas distribution facility change continuously for some reason, their operating mode changes. This makes it necessary to identify its mathematical model. All factors, as mentioned above, require a set of issues for the optimal management of gas lift wells [2].

Lifting small amounts of liquid through the air has been used in the United States since 1846. The use of

pressurized gas to extract oil from wells became widespread in the 1920s. The efficiency of a gas lift is higher than that of air, which can mix with flammable substances and cause oxidation of equipment. As early as the 1930s, various valves were used in gas lift lifts [3-4].

The gaslift method has been adopted as a competitive production method when there is sufficient gas pressure. Recently, the development of this method is going in two directions:

1. Extraction of a larger part of the produced oil from depleted wells.
2. Prevention of gas loss during gas lift operation.

In the gaslift process, high-pressure gas is continuously pumped into the well to restore the energy of the formation, thus bringing the liquid to the surface. The injected gas mixes with the liquid to form a liquid-gas mixture.

Due to the expansion of the pressurized gas, gas bubbles form in the liquid, and the weight of the liquid decreases. As one of the main methods of artificial lifting, a gas lift can be used in the following cases:

- Oil production immediately after the fountain method.
- Increasing well productivity at the end of the fountain method.

- Release of the well from substances affecting production before the transition to the fountain.
- Removal or discharge of liquids that interfere with production in gas wells.
- Removal of sand and other substances clogging the filters inside the well.
- Increasing productivity in water wells

In the operation of wells by the gas lift method, the liquid is released from the well under the influence of compressed air or gas. Depending on this, the well is called a gaslift or airlift well.

The main advantages of the method are: simplicity of equipment; ease of maintenance due to the fact that the equipment is placed on the surface; the volume of the extracted liquid; adjustable well productivity; saving gas injected by helping the gas in the well to lift the liquid [5].

The application of modern management technologies and systems and optimization methods, along with In the process of management and control, the system can work with different networks - enterprise networks, registration and alarm networks. In such an environment, it is advisable to use NETBIOS and TCP/IP protocols to achieve high efficiency.

## 2. Experimental details

To control the gas lift process, the pressure, volume or flow of injected gas, temperature, wellhead and wellhead pressures, flow rate of the liquid-gas mixture extracted from the well, the amount of oil and water should be measured separately after the mixture is fed to the separator.

The general structure of the management system includes the following key elements:

- well equipment;
- gas pipelines and oil network;
- local control system (controllers, measuring transmitters, local measuring devices and execution mechanisms);
- Automated workplace of the operator.

The necessary number of control and measuring devices and actuators are installed at the measuring and control points to control and manage the flow of the injected gas and its volume. If a high-pressure gas source is available, the compressor station and the system as a whole may have a simpler structure.

To measure the consumption of injected gas, the pressure drop and temperature are measured at the injection line. The approximate amount of liquid-gas mixture is determined by the liquid transmitter and the exact amount of oil is determined by group measuring devices. In this device, the liquid-gas

increasing the level of automation in the oil industry, allows to achieve the solution of the following issues:

- Ensuring continuity and safety of production.
- Continuously increase productivity.
- More efficient use of human resources as a result of automation of well management and stabilization of their operation [6].

Due to the high level of danger of gas lift oil production and petrochemical processes in general, the SCADA system has a separate module for emergency alarm and processing of information in case of accidents in the technological process, and these procedures are given the highest priority.

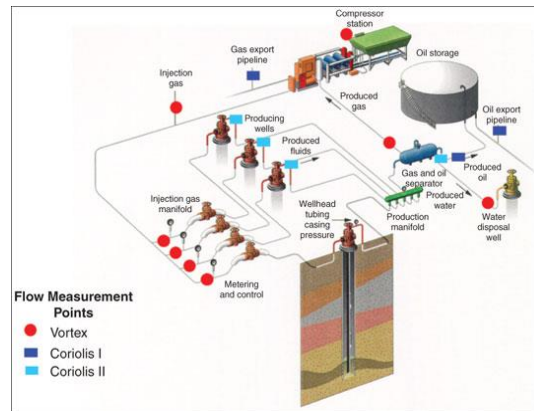

mixture is separated from the gas by separation, from the sediment by water and from mechanical particles. One of the important problems in the field of computer technology is the construction of a computer algorithm, ie the sequence of solving any problem, the sequence of process control. Accordingly, the gaslift system consists of determining the sequence of measurements, optimization solution, generation and application of control signals. In this case, the management issue is implemented taking into account the measurement results, technical and economic constraints, as well as the objective function. Provides oil extraction by regulating gas pressure and flow in the lift. The use of the agent's specific consumption parameter in management serves to increase economic efficiency as a result of management. The system automatically adjusts the required mode by reducing the volume of injected gas to the required level or from the maximum flow rate to the unstable region. The whole process of changing the regime can take from a few hours to a few days, which is necessary to obtain a stable situation. Optimal management of all wells can

also result in the closure of some wells, usually low-flow wells, when production is limited.

This control system collects data from wells - current mode parameters: debit, gas consumption information, collects, processes and, if necessary, generates a control signal to determine the mode parameters from the solution of the optimization problem, to convert the signals sent to the execution mechanisms to the appropriate code Siemens S7 -300 controllers were applied. One of the key issues here is the selection of the necessary interfaces to connect transmitters and execution mechanisms to the controller. The output signal of the debit and consumption sensors of the control subsystem is an analog signal, ranging from 0 to 5mA. Therefore, these signals are entered into the system through the I-7012 module. In this case, an additional 1250hm resistor connected in parallel is used.

It is advisable to control the motors, which are the main driving force of the actuator (valves and valves), by means of a voltage inverter with transverse pulse modulation.

The connection diagram of the engine driver to the I-7066 module is shown in Figure 1.

The local control unit is based on Siemens controllers, graphical programming is performed in FBD (functional block diagram) language. The main feature of the FBD language is that it describes the interaction between inputs and outputs in the form of block-functions.

The Siemens S7-400 controller is used to solve the optimization problem. In order to take full advantage of the capabilities of this controller with a modular design, the control system uses only the calculated values of tasks and parameters. The central processor unit of the controller performs the functions of process control and primary processing of information received from sensors (filtering, averaging, integration and differentiation) according to the program in accordance with the problem-solving algorithm. The exchange of information is carried out through the input-output module mentioned earlier.

Due to the high intensity of data processing when solving the problem of optimal distribution, it is necessary to have an auxiliary processor or signal processors that perform sliding point operations to perform operations of type  $Y = A \cdot B + X$  over a period of time. These processors can also perform fast Fourier conversions, which can speed up the initial processing of data. The modern development of the

oil industry can be made even more effective thanks to new materials [7-13].

### **3. Conclusions**

Based on the comparative analysis of industrial oil production processes, the features, advantages and disadvantages of the gas lift oil production method were identified. It was noted that the most suitable method of oil extraction immediately after the fountain method was the gas lift method, especially in deep wells.

Based on the analysis of mathematical models to describe oil extraction processes by gas lift, it was determined that the accuracy and reliability of the model proposed by Russian scientist A. Krylov is recommended to be used in most cases in connection with the conversion of wells to gas extraction. allows you to set design parameters and approximate operating modes.

Comparative analysis of mathematical models based on experimental studies has shown that the logarithmic-parabolic function is the most suitable among the proposed mathematical models for the approximation of measurement results obtained in the process of research in wells.

The analysis of options for realization of gas or working agent distribution between wells in one- and two-level schemes in the process of oil lifting by gas lift method and corresponding distribution schemes showed that in both cases the target function corresponding to the maximum product within certain limits for optimal distribution should be selected. The main limitation condition is that the amount of gas supplied to the gas distribution facility and in the field in general is often insufficient.

The two-level optimal distribution of the given amount of gas is also conditional on the limited amount of working agent injected into the wells connected to the gas distribution facility, provided that the amount of gas at the field is limited. Since the optimal distribution problem obtained in this case was a nonlinear problem, it was solved by the method of sequential approximation after bringing it to the problem of linear programming with linear-piece approximation to solve the problem with the required accuracy.

Using the values obtained in solving the problem of optimal distribution of operating parameters, the structure of the level system for well management and schemes of connection of transmitters to programmable logic controllers were developed,

appropriate equipment and input-output modules were

selected.

#### References

- 1.F.Buschmann, F.Buschmann, R.Meunier, H.Rohnert, P.Sommerlad, Stal M. Pattern-Oriented Software Architecture, Chichester. NY—Toronto—Singapore: John Wiley and Sons Ltd., 70 p., 2001.
2. E.Lee, S.Neuendorffer, M.Wirthlin, Actor-oriented design of embedded hardware and software systems, J.Circuits, Systems, and Computers, 206 p., 2003.
- 3.Lessons in Industrial Instrumentation, Tony R. Kuphald, 3183 p., 2016.
- 4.Measurement and Instrumentation Principles, Alan S. Morris. 491 p., 2005.
- 5.A.E.Platunov, et all., Problems of Abstract Representation of Embedded Systems at High-level Stages Design, Proc. Inte P.V.rn. Workshop on Networked embedded and control system Technologies, 107 p., 2009.
- 5.Sangiiovanni-Vincentelli A.Quo Vadis SLD: Reasoning about Trends and Challenges of System-Level Design, Proc. IEEE. Vol.95, 506 p., 2007.
- 7.R.G.Abaszade, S.A.Mamedova, F.H.Agayev, S.I.Budzulyak, O.A.Kapush, M.A.Mamedova, A.M.Nabiyev, V.O.Kotsyubynsky, Synthesis and Characterization of Graphene Oxide Flakes for Transparent Thin Films, Physics and Chemistry of Solid State, Vol.22, №.3, pp.595-601, 2021.  
[DOI: 10.15330/pcss.22.3.595-601](https://doi.org/10.15330/pcss.22.3.595-601)
- 8.S.R.Figarova, E.M.Aliyev, R.G.Abaszade, R.I.Alekberov, V.R.Figarov, Negative Differential Resistance of Graphene Oxide/Sulphur Compound, Journal of Nano Research Submitted, Vol.67, pp.25-31, 2021.  
<http://dx.doi.org/10.4028/www.scientific.net/JNanoR.67.25>
- 9.R.G.Abaszade, O.A.Kapush, S.A.Mamedova, A.M.Nabiyev, S.Z.Melikova, S.I.Budzulyak, Gadolinium doping influence on the properties of carbon nanotubes, Physics and Chemistry of Solid State, Vol. 21, No. 3, pp. 404-408, 2020.  
<https://doi.org/10.15330/pcss.21.3.404-408>
- 10.R.G.Abaszade, O.A.Kapush, A.M.Nabiyev, Properties of carbon nanotubes doped with gadolinium, Journal of Optoelectronic and Biomedical Materials, Vol.12, №3, pp.61–65, 2020.  
[https://www.chalcogen.ro/61\\_AbaszadeRG.pdf](https://www.chalcogen.ro/61_AbaszadeRG.pdf)
- 11.R.G.Abaszade, Analysis of carbon nanotubes, AJP Fizika, Vol.26, №2, section: Az, pp.25-29, 2020.  
[http://www.physics.gov.az/physart/256\\_2020\\_02\\_25\\_az.pdf](http://www.physics.gov.az/physart/256_2020_02_25_az.pdf)
- 12.R.G.Abaszade, S.A.Mamedova, F.H.Agayev, S.I.Budzulyak, O.A.Kapush, M.A.Mamedova, A.M.Nabiyev, V.O.Kotsyubynsky, Synthesis and Characterization of Graphene Oxide Flakes for Transparent Thin Films, Physics and Chemistry of Solid State, Vol.22, №.3, pp.595-601, 2021.  
[DOI: 10.15330/pcss.22.3.595-601](https://doi.org/10.15330/pcss.22.3.595-601)
- 13.O.A.Kapush, I.O.Mazarchuk, L.I.Trishchuk, V.Y.Morozovska, S.D.Boruk, S.I.Budzulyak, D.V.Korbutyak, B.N.Kulchitsky, O.G.Kosinov, R.G.Abaszade, Influence of the nature of the dispersion medium on the optical properties of CdTe nanocrystals during sedimentation deposition, Chernivtsi University Scientific Herald, Chemistry (819), pp.7-11, 2019.  
<https://doi.org/10.31861/chem-2019-819-01>

## **Reduction of obstacles and noise in TV broadcasting systems**

**J.F.Sultanova, M.T.Narimanli**

*Azerbaijan State Oil and Industry University, Baku, Azerbaijan,  
[Ceyransultanova11@gmail.com](mailto:Ceyransultanova11@gmail.com), [M.nerimanli@gmail.com](mailto:M.nerimanli@gmail.com)*

**Abstract:** Clearly, the signal/obstacle ratio depends not only on the impact noise, but also on external obstacles. One way to reduce these barriers to TV broadcasting is to perform proper frequency-distance planning, select the correct system parameters, and use more efficient methods during reception. The aggregation method was used to increase the resistance to obstruction. There is a correlation method for weakening the fluctuation barriers. Correlation refers to the relationship between two different random processes or at different moments in the same process. Such simple processes are signals and obstacles. As the correlation period increases, the correlation function decreases by a fraction of the maximum value. This method allows us to realize the correlation receiver.

**Keywords:** Obstacles, Correlation finder, Collection method, Correlation functions, TV broadcasting system.

### **1.Introduction**

Television broadcasting is one of the most widespread mass media of the population and is widely used in various fields of society. Television as a modern field of technology is developing and updating very quickly. Over the past few years, fundamentally new functional devices have appeared, image quality is constantly improving, special attention is paid to the reliability and efficiency of television receivers, TV control devices are being improved, and the use of microprocessor devices in television equipment is expanding. A television system is a collection of optical, electronic and radio devices used to transmit moving images over a distance.

The transmission of images in television is carried out electrically, i.e. the optical image is converted into an electrical signal transmitted over a communication channel, and then, at the receiving point, the electrical signal is again converted into an optical image. Ideally, the resulting TV image should exactly match the original. However, in this case, the TV system must be able to transmit an infinite amount of information, which will lead to a strong complication of the system itself. To limit the amount of information, it is necessary to set a certain degree of accuracy in the reproduction of a TV image, i.e. be limited to a specific purpose of the TV system. For TV broadcasting, when the image is perceived by the observer, the degree of image reproduction accuracy is limited by the physiological characteristics of vision: the resolution of the eye, its contrast

sensitivity and the inertia of visual perception. A modern TV broadcasting system consists of two parts: transmitting and receiving, connected by a communication line.

In the transmitting part of the system, the image of the object to be transmitted is projected onto the photo target of the transmitting tube located in the transmitting TV camera using an optical device (objective O). In the transmission tube, the optical image is converted into an electrical one. Using a sweep, this electrical signal is converted into a TV signal, which, after pre-processing in the TV camera amplifier (camera channel), enters the TV channel. To scan the image, electrical signals of the sawtooth form of the horizontal frequency (1) and field frequency (2) are applied to the deflecting system of the transmitting tube. These signals are generated in a special device – a scanning unit of the transmitting tube. In the TV channel, further amplification, distortion correction, and formation of a complete TV signal take place, for which quenching (3) and synchronizing (4) pulses of lines and fields are mixed into the signal. These pulses enter the TV channel path from a special pulse generator - a sync generator. The synchronous generator generates the pulses necessary for synchronous and in-phase operation of the entire TV system, i.e. provides a rigid ratio between the horizontal and vertical scanning frequencies.

The formed and amplified full TV signal is fed to the radio transmitter and then to the antenna.

**2. Experimental details**

One of the ways to increase the resistance is to use the assembly method ( Figure 1 ). The delay line, which has many outputs , includes pulses of duration  $t_i$  and period  $T_i$  - which enters the impulses.  $N$  - pulses are taken from the outputs of the delay line, each of which is measured for the duration of the pulse duration. The final delay is equal to the period of repetition of the pulses.  $G_1, G_2, .. G_n$  - amplifiers are used to amplify the impulses attenuated by the delay line. After amplification, all the reduced pulses enter the collector and the final signal at its

output is processed by the AITS filter are processed with and then the video is fed to the amplifier. Here, the increase in the S/M - ratio is due to the information redundancy due to the large number of repetitions of the received signal . In this case, the probability of distortion of the signal by interference is reduced. The degree of improvement depends on the number of repetitions, that is, the number of speeches on the line. Currently, sliding registers built on the triggers and controlled by a pulse generator are used as a delay line.

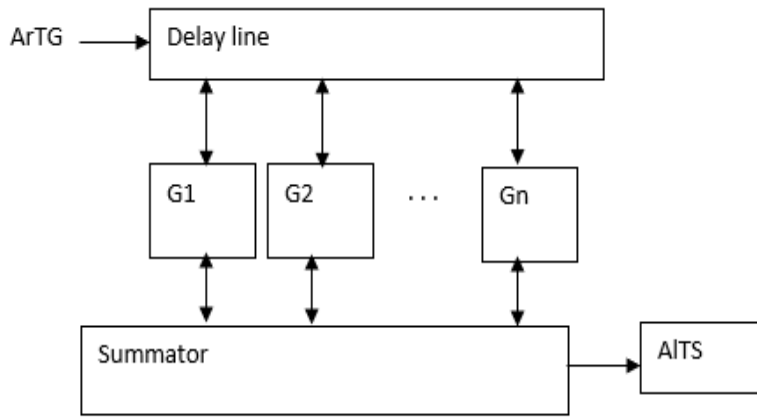

*Figure 1. Structural scheme of the collection method*

There is also a correlation method for weakening the fluctuation barriers. Correlation refers to the relationship of two different random processes or at different moments in the same process . Signals and interference can be shown as such random processes . As the correlation period increases , the correlation function decreases by a fraction of the maximum

value. The correlation function of the signal-noise mixture approaches any constant value as  $\tau$  - increases (Figure 2). The method considered allows the realization of the correlation receiver The block diagram of such a receiver is shown in Figure 2 .

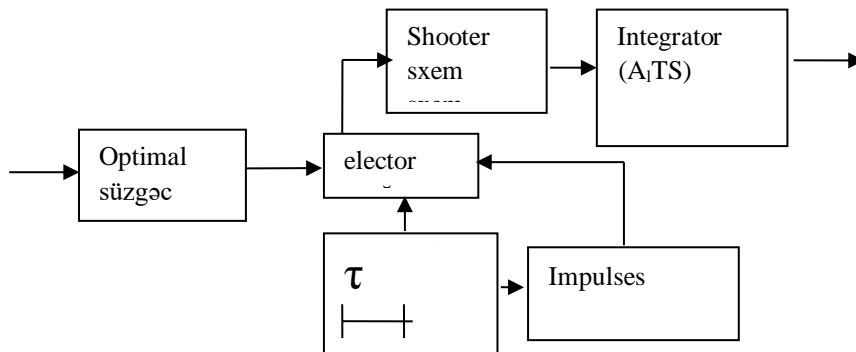

*Figure 2. Block diagram of the correlation receiver*

The signal and interference mixture passes through the optimal filter and enters the selector. The selector device is controlled by pulses 1 and 2, and pulse 2 is pulsed for a period of time  $\tau$ . The frequency of the

effect of selective impulses is chosen to be equal to  $T_i$ . During this period, two and adjacent values of the input signal are considered. The number of such values is equal to ( Figure 3 ).

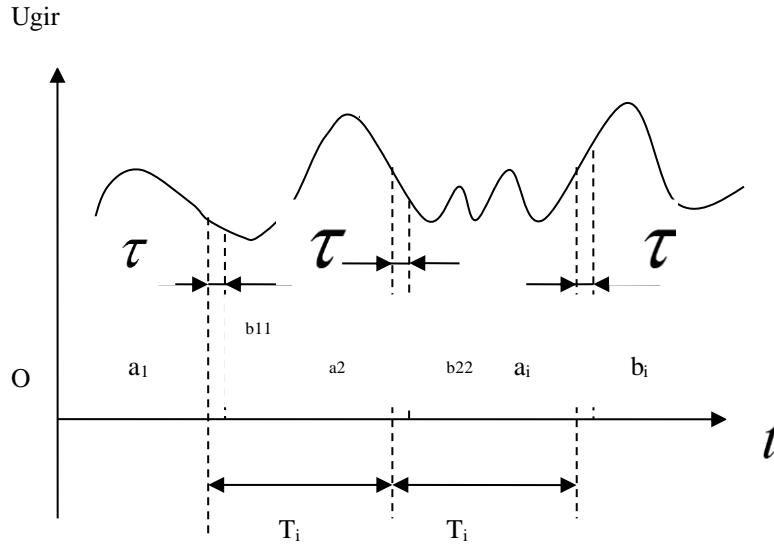

*Figure 3. Correlation acceptance principle*

By giving impulses from the selector device to the multiplier circuit, and then to the integrating circuit by AITS, we obtain the correlation function of the signal-noise mixture:

$$R(\tau) \approx \frac{1}{n} \sum_{i=1}^n a_i b_i$$

The block diagram of the correlation of dual signals is shown in Figure 4.

The purpose of the receiver is to detect the signal and to determine the form of the binary signal given at any given time. The received  $U_1$  or  $U_2$  signal is transmitted from the output of the ArTG to one of the inputs of the Striker 1 and Striker 2. Phase detectors can also be used as strikers. Integrators integrate the output of the reference and received signals over the duration of the signals. The solution circuit determines at the output of which integrator the result of the integration is large, ie which of the two signals is transmitted at a given moment. When the  $U_1$  signal

is passed, the Striker 2 will hit the obstacle mixture with this signal to the  $U_2$  reference signal, and the integrator 2 will integrate this product. Since there is little correlation between the  $U_1$  and  $U_2$  since there is little correlation between the signals and no correlation between the signal and the obstacle, the result of the integration will be less. At the same time, the striker 1,  $U_1$  - will hit the sum of the interference with the received  $U$  signal of the reference signal. Simply integrating the output of  $U_1$  and the obstacle will be less effective than before, but the signal square will be positive and its integration will be negligible. Accordingly, the resolution period  $U_1$  - will indicate that the signal has been passed. Similarly, when transmitting a  $U_2$  signal, the result of the integration at the output of integrator 2 will prevail and it will be noted that the  $U_2$  signal is transmitted.

One of the promising areas of modern electronics is limited quantum systems [7-14].



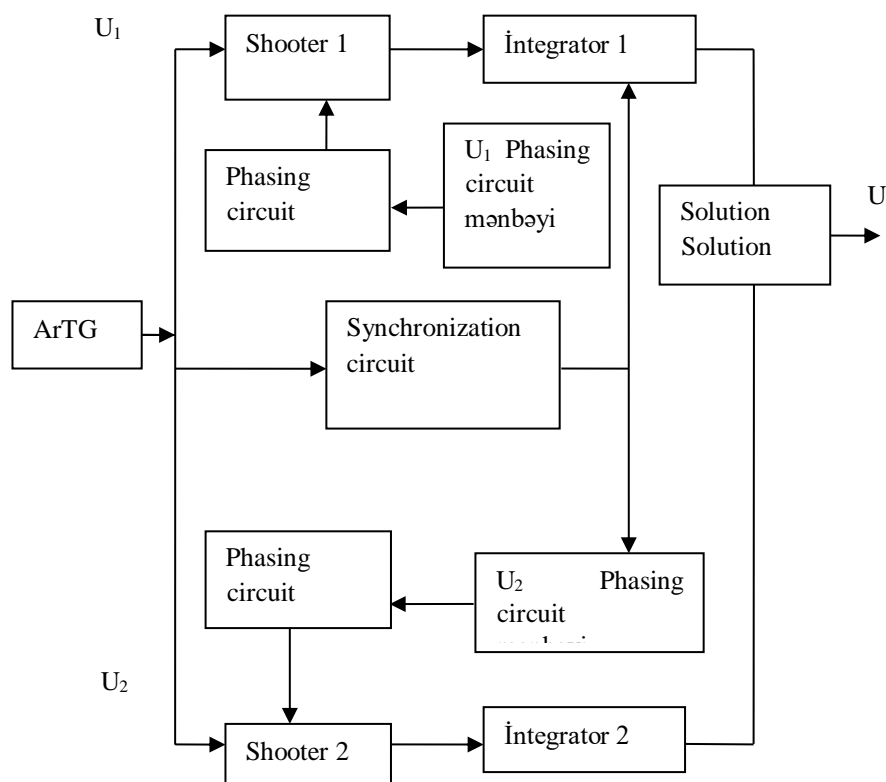

Figure 4. The structure of the correlation receiver of dual signals

### 3. Conclusions

One of the most effective ways to remove obstacles during signal transmission is a stacking method. The method is based on the use of the correlation principle. This principle, the signal is detected during

reception and the form of the binary signal given at any time is determined. Obstacles are effectively reduced as a result of the integration of the output signal.

### References

- 1.Z.A.Ismayilov, Reduction of non-linear interference during transmission of TV broadcast signals by digital communication systems. Dissertation for the degree of Doctor of Philosophy in Technology. Baku, 158p., 2015.  
<http://hozir.org/conference-proceedings.html?page=503>
- 2.A.I.Velichkin, Transmission of analog messages on digital communication channels, M.: Radio and communication, 240 p., 1983.  
<https://www.dissercat.com/content/razrabotka-sposobov-preobrazovaniya-rechevoi-informatsii-pri-peredache-po-telefonnoi-linii-s>

- 3.Yu.B.Zubarev, M.I.Krivosheev, I.N.Krasnoselsky, Digital television broadcasting. Fundamentals, methods, systems. M.: NIIR, 568 p., 2001.  
[https://niir.ru/wp-content/uploads/2014/12/DigitalTV\\_NIIR.pdf](https://niir.ru/wp-content/uploads/2014/12/DigitalTV_NIIR.pdf)
- 4.N.N.Krasilnikov, Theory of transmission and perception of images and its applications. M.: Radio and communication, 248 p., 1986.  
<http://oap.onu.edu.ua/article/view/96361>
- 5.U.Lie, Techniques of mobile communication systems: Per. с англ. M.: Radio and communication, 392 p., 1985.  
<https://www.dissercat.com/content/issledovanie-putei-povysheniya-pomekhoustoichivosti-ustroistva-priema-slozhnykh-signalov-v-s>

6.I.R.Mamedov, Transfer of stationary and graphic images. M.: Radio and communication, 1999, 128 p.

<https://www.dissercat.com/content/proektirovanie-informatsionno-izmeritelnykh-sistem-skanerov-s-mikrofilma>

7.R.G.Abaszade, S.A.Mamedova, F.H.Agayev, S.I.Budzulyak, O.A.Kapush, M.A.Mamedova, A.M.Nabiyev, V.O.Kotsyubynsky, Synthesis and Characterization of Graphene Oxide Flakes for Transparent Thin Films, Physics and Chemistry of Solid State, Vol.22, №3, pp.595-601, 2021.

[DOI: 10.15330/pcss.22.3.595-601](https://doi.org/10.15330/pcss.22.3.595-601)

8.S.R.Figarova, E.M.Aliyev, R.G.Abaszade, R.I.Alekberov, V.R.Figarov, Negative Differential Resistance of Graphene Oxide/Sulphur Compound, Journal of Nano Research Submitted, Vol.67, pp.25-31, 2021.

<http://dx.doi.org/10.4028/www.scientific.net/JNanoR.67.25>

9.R.G.Abaszade, O.A.Kapush, S.A.Mamedova, A.M.Nabiyev, S.Z.Melikova, S.I.Budzulyak, Gadolinium doping influence on the properties of carbon nanotubes, Physics and Chemistry of Solid State, Vol.21, №3, pp.404-408, 2020.

<https://doi.org/10.15330/pcss.21.3.404-408>

10.R.G.Abaszade, O.A.Kapush, A.M.Nabiyev, Properties of carbon nanotubes doped with

gadolinium, Journal of Optoelectronic and Biomedical Materials, Vol.12, №3, pp.61-65, 2020.

[https://www.chalcogen.ro/61\\_AbaszadeRG.pdf](https://www.chalcogen.ro/61_AbaszadeRG.pdf)

11.R.G. Abaszade, Analysis of carbon nanotubes, AJP Fizika, Vol.26, №2, section: Az, pp.25-29, 2020.

[http://www.physics.gov.az/physart/256\\_2020\\_02\\_25\\_az.pdf](http://www.physics.gov.az/physart/256_2020_02_25_az.pdf)

12.Kh.M.Popal, R.G.Abaszade, Research and modeling of hybrid energy systems (review), Ecoenergetics, №1, pp.65-69, 2022.

<http://ieeacademy.org/wp-content/uploads/2022/05/ECOENERGETS-JOURNAL-No1.-2022.pdf#page=66>

13.R.A.Namazov, R.G.Abaszade, Properties of graphene based solar panels (review), Ecoenergetics, №1, pp.3-8, 2022.

<http://ieeacademy.org/wp-content/uploads/2022/05/ECOENERGETS-JOURNAL-No1.-2022.pdf>

14.O.A.Kapush, I.O.Mazarchuk, L.I.Trishchuk, V.Y.Morozovska, S.D.Boruk, S.I.Budzulyak, D.V.Korbutyak, B.N.Kulchitsky, O.G.Kosinov, R.G.Abaszade, Influence of the nature of the dispersion medium on the optical properties of CdTe nanocrystals during sedimentation deposition, Chernivtsi University Scientific Herald, Chemistry (819), pp.7-11, 2019.

<https://doi.org/10.31861/chem-2019-819-01>

## **Ecological situation of Absheron peninsula and greening process in the Baku urban areas**

**H.I.Suleymanov**

*Azerbaijan University of Architecture and Construction, Baku, Azerbaijan,  
[hicranaxmed@mail.ru](mailto:hicranaxmed@mail.ru)*

**Abstract:** Ecological situation of capital of Azerbaijan is really different, there too many cases and environmental issues covered in this topic, Absheron peninsula is really complex structure for Azerbaijan. Within the decades too many operations and urbanization processes have made different formalized city projection for the capital of Azerbaijan. In this thesis we will give information about the Absheron peninsula next-gen urbanization progress and useful power-energy systems those can be allocated with Baku

**Keywords:** Smart materials, Process, Power energy.

### **1.Introduction**

It seems that the global environmental problem is gradually gaining in the minds of the world community the importance it deserves. This is evident from the decision to award the Nobel Peace Prize for at least 2007 to the former US Vice President Al Gore and the Intergovernmental Panel on Climate Change (IPCC) "for efforts to create and disseminate greater knowledge." on techno genic climate change and to lay the foundation for the measures necessary to combat this change". Despite this, the number of agencies for the growing Green Movement is growing protection of the environment in different countries, as well as growing clearly report the Environmental Protection technology market momentum the environmental threat was finally acknowledged by mankind. As a result, a wide range of environmental problems emerged, including anthropogenic climate change ("global warming"), ozone depletion in the stratosphere ("ozone hole"), surface water acidity ("acid rain"), tropical forest destruction, species depletion and depletion. And a sharp decline in biodiversity. However, even if all these problems are physical (environmental) manifestations, their causes - and their potential solutions are always related to human relationships, beliefs, values, needs, desires, expectations and behavior. Thus, the signs of an ecological crisis cannot be considered as physical problems that require a solution by purely ecological "specialists"; instead, they are essentially human problems and are closely related to the question of what it means to be human. The Republic of Azerbaijan and over 2800

hectares of land contaminated. Soil pollution rate from 1-2% to 30-40%, its depth reaches 2-3 meters or more. Complete industrialization Peninsula and semi-desert natural habitat decreased the ability to restore the soil itself. No sign natural ecosystems on the peninsula. The climate of Absheron is moderately hot and dry subtropical. The sunshine of the year is 2200-2400 hours. Average the temperature of the coldest month indicates that the hardness winter is very mild (0; -5°C), very mild (2.5-0°C) and extremely soft (5-2.5°C). The country is the least rainy (200-400mm) and the windiest fields. Possible evaporation in hot periods (April-October) 1000 mm. The number of dry days in June-September about 5-25 days. One of the main problems of Absheron, the peninsula is related to soil pollution. The total area of the useless Absheron Peninsula is 222,000 the hectare is 33,300 hectares, including land contaminated with oil up to 10,000 hectares. Measures are being taken in the direction of sewage disposal residential buildings in Baku and the Absheron peninsula, reconstruction and construction of existing treatment plants completion of reconstruction of new treatment plants at the end of 2009, the Hovsan Ventilation Station and sewerage into the bay to the ventilation station will be positive on the effect of gradual cleaning of the Baku bay. To improve the ecological situation of the Caspian Sea, module-type local water treatment plants have been built.

The rapid development of science, along with the application of smart materials, expands their application in ecoenergy [1-7].

The surface is represented by sediments quaternary marine and terrestrial lithological derivatives of Paleogene and Neogene systems. Quaternary deposits consist of loamy sands with a small thickness of gray and brown clays. From the hydrogeological point of view, the research area is called the central district of Western Anatolia. It is part of the Absheron peninsula. Cretaceous and Miocene - Paleogene sediments common in Turkey, this area is characterized by a situation that is most often inappropriate in terms of groundwater formation. Such fresh drinking water resources in the region are almost non-existent. It is possible to find sources of drinking water. deluvial - proluvial sediments and existing Caspian sediments in different areas.

National Environmental Action Plan (NEAP) has been in effect since 1997. More recent strategic documents (2001 State Poverty Reduction Program and Economic Development and the 2003 State Program Environmentally Sustainable Economic Development) rephrase and add however, before recommending which sequence environmental priorities they should be supported by public investments. A ranking is strictly based on it is unlikely to arise on the criteria of economic efficiency. A more likely a politically determined balance of attention to different broad concerns but after that the economy is supported prioritization within each broad category. Industrial base it was established in Azerbaijan to process Caspian oil for the needs of the Soviet Union. In the Union, the Soviet-era industrial supply once became largely inappropriate the arrangements collapsed. Reduction of industrial discharges improved ambient air quality in the Baku-Sumgait region, but left the big old problem of contamination unsolved. As it is,

especially the Absheron Peninsula (coastal areas) suffer from oil and other chemical species. The problem of abandoned industrial facilities, old waste is found in many other places in Azerbaijan, but not in the same place. The structure of fuel oil taxation is more than that of high-income countries, it has far-reaching environmental impacts in Azerbaijan. Azerbaijan it has responded to almost all the main international and sub-regional problems. Environmental contracts Performance under these contracts, biodiversity is uneven, with some delays in climate change and land XVI Country Environmental Analysis-Azerbaijan the deterioration, however, the record has been good under the Caspian Environment, a significant level of directed development partner financing environmental priorities have been realized since 1995, when it was once the worst in the world. The refugee crisis and emergency aid had passed. It is no different from the center there may be a disproportionality between the levels of support for national, environmental, sub regional and cross-border activities. Coordination of development partner environmental assistance although working relationships arise between them, they are decently inadequate. Development partners in some important areas such as water and sanitation. Development partner leadership in key environmental-related areas activities is sorely needed to complete the government's efforts to achieve greater success, the degree of corporate consistency. Preparation of SPPRED II, structured it can provide an opportunity to move around thematic groups. The role of private sector organizations as environmental development partners it wasn't appreciated enough and some potential lessons were missed.

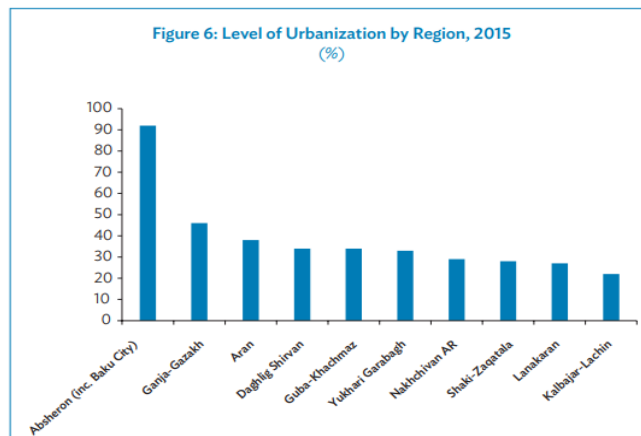

## **2. Experimental details**

In most cases, green spaces are representative of the entire city, which is the result of extraordinary diversity. Green trees and architectural heritage and archaeological sites that have stood the test of time, conflicts at rapid rates with the new functions and developments taking place around them. These areas tend to serve as central public spaces of the city, as they are often visited. This is what we owe high percentage of ecological functions, public buildings and offices in which the environment is located. Inside in this way, the green architecture of the city tends to both represent and reveal a lot about the architecture of the city. The ecological performance and success of sustainable planning thus gives it a significant advantage and value. If the green areas are identitarian, the core for the city in both historical and geographical sense, they are also at the center of many difficulties and obstacles. The explosion in the urban population is partly to blame for this. Inside By 2007, the world's urban population had exceeded its rural population, and by 2050, the world's urban population expected to increase by the most 65%. Green city areas around the world witness the multitude of undesirable effects that are the result of crushing waves of rural migration. This resulted in the urban fabric as a result. Found today; with the Core City in the center and the seven metropolitan rings surrounding it. Both urban planning and increasing the ecological performance of the Green Core City of Baku, which is considered a city green area. Within the scope of the research conducted by researchers looking at urban planning; environment Ecological development carried out in some Caspian cities is classified under different strategies. These strategies can be classified under five main areas. In addition, environmental audits and controls are carried out to ensure the implementation of environmental laws definitely implemented. A large part of the city council's commitment to sustainability involves conservation and the improvement of public spaces within the Green Core City as man-made elements. Both the natural environment public spaces in Baku

## **3. Conclusions**

As it comes to the conclusion people mostly populated in this area this one of the lack of factorial opportunity that city is growing and developing but country's economy will remain stable, in this case

follow a distinct style and tradition, this extends to planning. The need for the development of the public spaces of the Green Core City was initially recognized in the 2000s and improvement began before the 2012 Eurovision. To transform Baku into a "City of Public Space" as a result, all green spaces such as Park Road from Fizuly, which is designed like a seaside Park and where the existing urban green spaces are even more developed. The Beach Park continues to stand as an important aspect of Baku public space design, prioritizing pedestrian activity, providing a meeting point and increasing social interaction between them both citizens and tourists. Sustainable urban planning adds arguably the most important value, sublimity and physical integrity. Promotes the city and its cultural heritage. Also, urban planning can be considered as the right way. Sustainability, because urban planning often addresses the many harmful environmental problems it has recently been recognized as characteristic of crowded city centers and urban environments. Metropolis city of Baku is an example of a historical city that emerged as a medieval city and expanded as a medieval city. Linear direction next to the Caspian Sea coast, achieving the metropolitan status for which it is known today parts of this town have been converted to Green periodically over time the main city of Baku, is a popular for tourist attraction. But this proof is efficient, still important point out that spontaneous events should never be left to initiate such good practices in the planning of sustainable cities. Planning and projects of green architecture aimed at growth the green areas in the core city and it has continued to be transformed into a 'public space city' over the years and in constant focus. Sustainable urban planning projects are carried out continuously. Designed and implemented to overcome undesirable environmental problems and transform this green areas to a sustainable part of the city to the greatest extent possible. It is clear that sustainable cities and their green structural components provide an opportunity for new innovations and developments of green architecture.

GDP will belong to the capital city, will not be separated fairly enough among the other cities. Urbanization is one of the best factor countries like

Azerbaijan but if it will exceed the limit country's economy and demography will be affected very bad.

### References

- 1.G.Notton, M.Muselli, A.Louche, Autonomous hybrid photovoltaic power plant using a back-up generator: a case study in a Mediterranean Island, *Renew Energy*, 7(4), pp.371–91, 1996. <https://econpapers.repec.org/scripts/redir.pf?u=https%3A%2F%2Fdoi.org%2F10.1016%252F0960-1481%252896%252900016-X;h=repec:eee:renewe:v:7:y:1996:i:4:p:371-391>
- 2.R.G.Abaszade, S.A.Mamedova, F.H.Agayev, S.I.Budzulyak, O.A.Kapush, M.A.Mamedova, A.M.Nabiyev, V.O.Kotsyubynsky, Synthesis and Characterization of Graphene Oxide Flakes for Transparent Thin Films, *Physics and Chemistry of Solid State*, Vol.22, №3, pp.595-601, 2021. [DOI: 10.15330/pcss.22.3.595-601](https://doi.org/10.15330/pcss.22.3.595-601)
- 3.S.R.Figarova, E.M.Aliyev, R.G.Abaszade, R.I.Alekberov, V.R.Figarov, Negative Differential Resistance of Graphene Oxide/Sulphur Compound, *Journal of Nano Research Submitted*, Vol.67, pp.25-31, 2021. <http://dx.doi.org/10.4028/www.scientific.net/JNanoR.67.25>
- 4.R.G.Abaszade, O.A.Kapush, S.A.Mamedova, A.M.Nabiyev, S.Z.Melikova, S.I.Budzulyak, Gadolinium doping influence on the properties of carbon nanotubes, *Physics and Chemistry of Solid State*, Vol.21, №3, pp.404-408, 2020. <https://doi.org/10.15330/pcss.21.3.404-408>
- 5.R.G.Abaszade, O.A.Kapush, A.M.Nabiyev, Properties of carbon nanotubes doped with gadolinium, *Journal of Optoelectronic and Biomedical Materials*, Vol.12, №3, pp.61–65, 2020. [https://www.chalcogen.ro/61\\_AbaszadeRG.pdf](https://www.chalcogen.ro/61_AbaszadeRG.pdf)
- 6.R.G.Abaszade, Analysis of carbon nanotubes, *AJP Fizika*, Vol.26, №2, section: Az, pp.25-29, 2020. [http://www.physics.gov.az/physart/256\\_2020\\_02\\_25\\_az.pdf](http://www.physics.gov.az/physart/256_2020_02_25_az.pdf)
- 7.Kh.M.Popal, R.G.Abaszade, Research and modeling of hybrid energy systems (review), *Ecoenergetics*, №1, pp.65-69, 2022. <http://ieeacademy.org/wp-content/uploads/2022/05/ECOENERGETS-JOURNAL-No1.-2022.pdf#page=66>
- 8.R.A.Namazov, R.G.Abaszade, Properties of graphene based solar panels (review), *Ecoenergetics*, №1, pp.3-8, 2022. <http://ieeacademy.org/wp-content/uploads/2022/05/ECOENERGETS-JOURNAL-No1.-2022.pdf>
- 9.O.A.Kapush, I.O.Mazarchuk, L.I.Trishchuk, V.Y.Morozovska, S.D.Boruk, S.I.Budzulyak, D.V.Korbutyak, B.N.Kulchitsky, O.G.Kosinov, R.G.Abaszade, Influence of the nature of the dispersion medium on the optical properties of CdTe nanocrystals during sedimentation deposition, *Chernivtsi University Scientific Herald, Chemistry* (819), pp.7-11, 2019. <https://doi.org/10.31861/chem-2019-819-01>

## Adaptive diagnostic systems for cable communication lines

R.A.Mayilov, E.A.Khanmamedova, K.N.Hummatli

Azerbaijan State University of Oil and Industry, Baku, Azerbaijan,

[mayilov.rauf@mail.ru](mailto:mayilov.rauf@mail.ru) , [elmira.khanmammadova@asoiu.edu.az](mailto:elmira.khanmammadova@asoiu.edu.az) , [qulu7776@gmail.com](mailto:qulu7776@gmail.com)

**Abstract:** Modern information transmission systems incorporate elements of traditional information perception, transformation and reflection, as well as information processing devices that allow to improve the parametric properties of these systems. One of the main places among these devices are filters, which in our case, optimally separate pulse signals from the background of interference, which carries information about any process, in our case, the heterogeneity of cable lines, and adaptive diagnostic devices for cable lines.

**Keywords:** Communication, Cable lines, Capacity, Inductiveness, Transmission, Electromagnetic energy, Electrical processes.

### 1.Introduction

The development of modern electronics has taken place with the extensive analysis and application of smart materials [1-7].

It is known that the method that can provide the widest possible automation of the process among the methods of control of cable lines is the study of lines by pulse reflectometry. With this method, a pulse is sent to the line during the measurement, and this pulse is reflected from the heterogeneity and returned [10,11]. The transmitted (probing) and reflected pulses are observed on the screen of the electron-beam tube and judged on their heterogeneity or line damage according to their shape (type).

The reflected pulses return to the measuring device after a certain moment. Knowing the rate of propagation of electromagnetic energy in the line  $v$  and the time of transmission of the pulse from the beginning to the place of injury and back, it is

possible to determine the distance  $l_x$  to the place of damage.

$$l_x = vt/2$$

As an example of the pulse method, we can show the serial output line damage skin measuring devices and P5 type cables. (Fig 1) These types of devices are mainly based on technological data, such as the range of distances measured from the injury to the skin, the distance measured by the error of measurement, the amplitude, the duration and form of the probing pulse, the required power, etc. differ by. With the help of these devices, damage sweat (short circuit, cut) is found, the length of the temporary delay of the cables is measured.

Using the results of the pulse method, it is also possible to use digital signal processors as a device that analyzes the electrical parameters of cable lines.

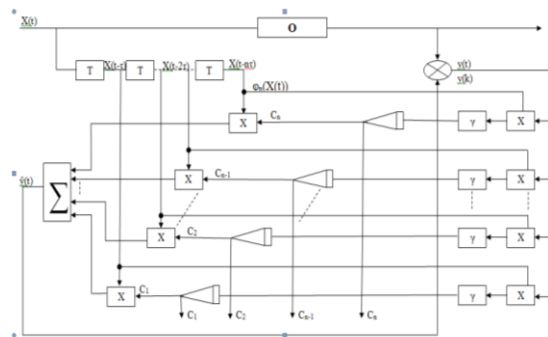

Figure 1. Block diagram of the diagnostic system

## 2. Experimental details

In most cases, computing devices must operate in real time and be aware that the operating program is running for a period of time limited by the sampling period of the initial signal. It is considered to be one of the most difficult operations in computing devices. Thus, the hardware part requires relatively many purposes.

A typical system of digital signal processing consists of three main parts:

- 1) analog digital converter with analog multiplier, ie switch, amplifier, input register;
- 2) arithmetic logic device, which includes micro-processor control controllers, data memory device, coefficient memory device, command memory and multiplier;
- 3) The output section of the main block digital analog converter.

The signal bandwidth of a digital processing system is primarily determined by the speed of the ARC and the performance of the processor unit. At present, six-layer APCs with a clock frequency of 0.5 GHz have been developed.

$$\hat{I}(j) = \sum_{i=1}^k U(j-1)S(i)$$

where the number of pulses in the k-series is the quantities U and S, discrete according to the level U (j-i), S (i), expressed by the signless binary number. j is the number of the pulse at the beginning of the current period

This algorithm is the basis for built-in receiving devices based on the calculation of the Z (j) correlation integral. In this case, the following operations are performed: receiving the next signal in the buffer memory; multiplying each U (j-i) signal by the corresponding S (i) signal; Obtaining the value of the correlation integral Z (j). Comparing the value of Z (j) with the value of the given task (comparison) (); The U (j-i) values are obtained from an analog digital converter connected to the output of the receiver's detector, and the values of the S (i) coefficients are pre-calculated and stored in the microprocessor's processor's non-volatile memory.

Analysis of methods for determining the heterogeneity of cable communication lines shows that the most optimal method for determining the location of damage in cable lines is the method of pulse reflectometry, based on the transmission of a sounding pulse to the line. However, the selection of information-carrying impulses returning from the site

of injury against the background of various obstacles is one of the most important issues.

It is advisable to use an adaptive learning approach to solving a problem when the cable lines are strongly exposed to non-homogeneous point signal reflection during the pulse study, ie under conditions of uncertainty in both amplitude and time distortion. is done.

It is known that the principle of operation of self-learning systems is based on the use of a learning process that complements the shortcomings of the initial a priori information on the basis of probabilistic-iterative algorithms as a result of processing current information in realizations. In this case, the problem of learning leads to the transmission of an impulse on the line to study the cable lines and the sugaring and classification of the impulse returning from the site of injury.

On the other hand, due to the shape and temporary location, the reflected signal is distorted in one or another section of the multi-section cable. The signal reflected from the strong impact of the obstacle is distorted by both amplitude and time. In such uncertainty, in other words, it is advisable to use an adaptive learning approach to solving the problem [8-15]. The learning process is carried out using probabilistic, iterative algorithms, which are also called algorithmic learning. In a particular case, the object studied is characterized by a set of numbers or a set of signs, and finding patterns leads to the division of the space of signs into areas.

The problem of classifying or recognizing the signal according to the location of the damage for the case under consideration results in the construction of surfaces that divide the hyper space into a finite number of areas (cable sections). Each of these areas has its own example.

To solve the problem, consider the problem of dividing the function by surfaces. where - characterizes the property of damage analyzed in separate sections of the cable. Such a vector is often a set of elements x [i]. i = 1, N where N is the number of sections in the cable. In a real learning system, x [i] will correspond to different displacements of the sent signal. Y will match the reflected signal and a non-uniform part of the cable line will be detected by matching x [i].

To solve the problem, we write the approximation function as follows.

$$\hat{y}(x) = CT \varphi(x) = \sum C_i \varphi_i(x_i)$$



Here  $\varphi_i()$  is a linearly independent, mutually orthogonal function.  $C_i, i = 1, N$  are the coefficients of the approximation function.

The purpose of the study is determined by the error of the approximation evaluated by the following functionality:

$$I(C) = MX \{F(y - CT \varphi(x))\}$$

Here  $F$  is a strictly convex function.

On the other hand, since the quadratic inclination is taken as a function, the gradient will be determined according to the following rule:

$$Q(x, C) = [y - CT \varphi(x)] \varphi(x)$$

### 3. Conclusions

One of the factors characterizing the effectiveness of communication systems is to ensure the accurate transmission of measurement information through these systems. Among other factors, the transmission of information in these systems is a change in its basic characteristics as a result of a violation of the homogeneity of the cable lines through which the information is transmitted.

Damage to the line during the transmission of measurement signals by broken cable communication lines, in turn, leads to distortion of the basic parameters of the transmitted signal. In such cases, it is possible to recover the information in accordance with the developed correction algorithm by obtaining information about homogeneity using the method of pulse reflectometry.

Quality control of cable lines is one of the factors influencing the quality of work during the diagnosis

In this case, the continuous algorithm will take the following form.

$$dC / dt = + \gamma(t) \{y(t) - CT \varphi(x)\} \varphi[x(t)]$$

Here,  $\gamma(t) = a / (a + t)$  is a parameter that takes into account the best values of the quantity  $C$ .

$a$  - a parameter that characterizes the speed of compliance

$t$  - sent signal;

$y(t)$  - approximation function;

$\hat{y}(t) = T [t]$  - is an approximation function depending on the unknown parameter vector;

$\varphi[x(t)]$  is a vector of mutual orthogonal functions consisting of  $x(t - iT)$ ;

$T$  is the delay time of the reflected signal in one section of the cable.

of technical equipment in the oil industry. The system of automatic diagnostics of the characteristics of cable communication lines allows to increase the overall operation and efficiency of diagnostic devices in the oil industry.

Developed on the basis of an automatic diagnostic system of the main characteristics of cable lines, the correction system of measurement signals transmitted by inhomogeneous lines provides an increase in measurement accuracy in technical processes using cable lines by correcting information transmitted by damaged lines.

Automatic diagnostics of the main characteristics of communication lines increases the overall efficiency of the system, helping to ensure accurate data transmission in these systems.

### References

1.R.G.Abaszade, S.A.Mamedova, F.H.Agayev, S.I.Budzulyak, O.A.Kapush, M.A.Mamedova, A.M.Nabiyev, V.O.Kotsyubynsky, Synthesis and Characterization of Graphene Oxide Flakes for Transparent Thin Films, Physics and Chemistry of Solid State, Vol.22, №3, pp.595-601, 2021.

[DOI: 10.15330/pcss.22.3.595-601](https://doi.org/10.15330/pcss.22.3.595-601)

2.S.R.Figarova, E.M.Aliyev, R.G.Abaszade, R.I.Alekberov, V.R.Figarov, Negative Differential Resistance of Graphene Oxide/Sulphur Compound, Journal of Nano Research Submitted, Vol.67, pp.25-31, 2021.

<http://dx.doi.org/10.4028/www.scientific.net/JNanoR.67.25>

3.R.G.Abaszade, O.A.Kapush, S.A.Mamedova, A.M.Nabiyev, S.Z.Melikova, S.I.Budzulyak, Gadolinium doping influence on the properties of carbon nanotubes, Physics and Chemistry of Solid State, Vol. 21, №3, pp. 404-408, 2020.

<https://doi.org/10.15330/pcss.21.3.404-408>

4.R.G.Abaszade, O.A.Kapush, A.M.Nabiyev, Properties of carbon nanotubes doped with gadolinium, Journal of Optoelectronic and Biomedical Materials, Vol.12, №3, pp.61-65, 2020.

[https://www.chalcogen.ro/61\\_AbaszadeRG.pdf](https://www.chalcogen.ro/61_AbaszadeRG.pdf)

5.R.G.Abaszade, Analysis of carbon nanotubes, AJP Fizika, Vol.26, №2, section: Az, pp.25-29, 2020.

[http://www.physics.gov.az/physart/256\\_2020\\_02\\_25\\_az.pdf](http://www.physics.gov.az/physart/256_2020_02_25_az.pdf)

6.Kh.M.Popal, R.G.Abaszade, Research and modeling of hybrid energy systems (review), Ecoenergetics, №1, pp.65-69, 2022.

<http://ieeacademy.org/wp-content/uploads/2022/05/ECOENERGETS-JOURNAL-No1.-2022.pdf#page=66>

7.R.A.Namazov, R.G.Abaszade, Properties of graphene based solar panels (review), Ecoenergetics, №1, pp.3-8, 2022.

<http://ieeacademy.org/wp-content/uploads/2022/05/ECOENERGETS-JOURNAL-No1.-2022.pdf>

8.R.A.Mayilov, E.A.Khanmammadova, Correction of electrical signals transmission results on the damaged communication lines, 18th IFAC Conference on Technology, Culture and International Stability TECIS 2018: Baku, Azerbaijan, 13–15 September 2018.

9.L.R.Rabiner, B.Gold, Theory and application of digital signal processing, Englewood Cliffs, N.J., Prentice-Hall, Inc. 1975.

10.Analog and digital filters: design and realization. Harry Y., F Lam Bell Telephone Laboratories, Inc. Prentice-Hall Inc, New Jersey, 1979.

11.W.F.Leahy, Microprocessor architecture and programming, A. Wiley. Interscience Publication Co., N. V. 1979.

<https://worldradiohistory.com/Archive-Electronics/70s/79/Electronics-1979-09-13.pdf>

12.J.Plenatly, Principles of measurement system. N.Y, London Inc Construction press , p. 400., 1993.

<https://uvceee.files.wordpress.com/2016/09/principles-of-measurement-systems-20051.pdf>

13.M.S.Kupriyanov, B.D.Matyushkin, Digital signal processing: processors, algorithms, design tools. - SPb.: BHV-Petersburg, 2001.

14.A.I.Solonina, D.A.Ulahovich, L.A.Yakovlev, Algorithms and signal processors, SPb.: BHV-Petersburg, 2001.

15.O.A.Kapush, I.O.Mazarchuk, L.I.Trishchuk, V.Y.Morozovska, S.D.Boruk, S.I.Budzulyak, D.V.Korbutyak, B.N.Kulchitsky, O.G.Kosinov, R.G.Abaszade, Influence of the nature of the dispersion medium on the optical properties of CdTe nanocrystals during sedimentation deposition, Chernivtsi University Scientific Herald, Chemistry (819), pp.7-11, 2019.

<https://doi.org/10.31861/chem-2019-819-01>

## **Contribution to high performance computing and big data infrastructure convergence**

**S.T.Mirzahmadova**

*Azerbaijan State University of Oil and Industry, Baku, Azerbaijan,*

[m061712020@asoiu.edu.az](mailto:m061712020@asoiu.edu.az)

**Abstract:** The most preeminent difference between HPC and Big Data is their purposes: Big Data is a field of research that was invented to distribute the processing of large amounts of data, while HPC is simply the more advanced computer for parallel computation. But, in order to clarify what really is Big Data and what is HPC, we need to define them precisely. First, what those terms refer to? They both defined a field of research in Computer Science, closely related to industrial and production concerns. But, their purpose is different. This chapter is an attempt to define those terms, beyond the buzz words, by comparing them and exposing their differences and similarities.

**Keyword:** High performance computing, Big Data, Infrastructure, Convergence.

### **1.Introduction**

In the source element in the field of information and Communication Technologies has become important in recent years, major developments as a result of labor, capital and natural resources, as well as new information that takes place as a production factor, the organizations to achieve competitive advantage. Innovation is a necessity that organizations give up in order to gain a sustainable competitive advantage. Again, information shapes the nature of innovation. Giving information to achieve certain goals or have a certain meaning is a process of transformation and analysis that is eventually put into a format useful for managers. In other words, the information that managers use in making decisions, processing information in a useful and meaningful data processes helping you achieve success by insertion shape when subjected to the decisions of the value of raw data that must be processed before it becomes meaningful and useful information of exchange refers to informational substances. In this context, making strategic decisions with a data-based approach is of great importance for organizations to maintain their existence and to make innovation-based competitive advantage sustainable. The proliferation of smart devices used with the development of technology, the fact that devices produce real-time event records with the help of sensors, social networks become part of our lives every day with the increase of mobility and Internet access, increases the variety, speed and volume of data that surrounds us. This situation also brings with it the problems of receiving, storing,

processing large data at the same speed. At this point, information access is provided through big data analysis, selection, storage and processing of appropriate ones from structured corporate data and non-structured data world such as video, audio, text files. The dependence on social media applications, the use of sensors that collect data, and smartphones has intensified the amount of data transmitted on networks. This transmitted data is of a generally non-structural type and is obtained from different sources in different formats. Relational databases are insufficient to process such data on a large scale and in different configurations, and this makes it necessary to use systems that support the storage of non-structural data and have distributed parallel processing capabilities. While it is accepted that there are significant benefits in many areas with big data analytics, other issues related to big data, from ethical regulations to mechanisms to be developed to ensure the privacy and security of users, should also be taken into account. Because the potential for big data to be analyzed also raises concerns about breaching privacy and restricting areas of personal freedom. In this study, respectively, the concept of big data, taken up in the size of components and resources, focused on the advantages in the field of application of Big Data Big Data Analytics Big Data Analytics which form the basis for processes running on a distributed file system and Map - Reduce model, and the computational principles of operation of the software architecture are examined, Hadoop, big data points to

be considered are pinpointed in the field of security, and the security measures that need to be taken in this

## **2. Experimental detail**

Big data can be generated in any type and format over a wide range of dec, and there are no standard sets or rules between these mixed data types. The data is presented in three types: structural, semi-structural and non-structural. In other words, diversity refers to the structural heterogeneity in a data set. Non-structural data constitute 95% of this heterogeneous structure. As a matter of fact, the vast majority of the data produced today is of a non-structural type and is fed from various sources such as Facebook, Twitter and video content. Structural data can be easily stored and labeled in databases. From this point of view, big data does not have the same defined format and length as structural data. It is quite difficult to store and analyze non-structural data with relational database systems that are used for structural data, where row and column information are located in a certain order. Because non-structural data cannot be stored in rows and columns in a relational database. Semi-structured data, on the other hand, does not have a specific structure that can be placed in relational database tables, such as a non-structured data type, but it is a data type that can be labeled to separate or put the data in a certain order. Tagging allows similar data to be grouped together. For example, a call center's conversation logs may contain the customer's name, conversation time, conversation duration, and the subject of the complaint. As can be seen from the call center example, speech recording data can be grouped, but the data in the complaint subject group cannot be placed in relational databases because it contains non-structural data [3-19].

Data is constantly in motion. In this context, the analysis of data flow has become one of the important issues for data scientists. The speed of production of big data is very high, and every day this speed is increasing more and more. Speed is an important factor not only for big data, but also for all business processes. From this point of view, the processes that will process and analyze the data should also be at the same speed as the production of big data. Examples of how fast big data is generated include clicking on likes and sharing comments 2.7 billion times a day on Facebook, sending 350 thousand tweets per minute and 500 million tweets per day via Twitter, processing 50 billion messages per day on WhatsApp, and sending and receiving more than 200 billion emails per day worldwide. Apart from social media, there are many fields of study that will serve as an example of the speed of data production. For example, every 30 minutes a jetliner flies, it collects 10 terabytes of data through its sensors. Similarly, in

context have been evaluated.

a Formula 1 car race, 20 gigabytes of data are generated by means of 150 sensors located on a car. Another example of the speed of production of large data is the fact that 1 petabyte of data per second was generated using sensors in the "Large Hadron Collider" experiment conducted at the European Nuclear Research Organization [4]. In order for these changes to take place and to have positive results, there must be societies that are open to change and prepared for this change. We can say that information and technology are two drugs that will eliminate or reduce the different responsibilities that the new century will impose on societies and the problems that will arise with it. With these drugs, businesses also achieve the ideals of maximum profit, more efficient organization, minimum cost, effective performance or high performance, which is one of their ultimate goals. Information Systems As the name given to the sum of meaningful data that has been passed through a process, information is a necessary tool or resource for making a rational decision. On the other hand, a system; it is defined as a whole or process of interrelated elements that work together to achieve a common goal or dec. In the system approach, information is usually obtained in two ways: manually or automatically. In our time, when we talk about the concept of an information system, we mean information systems that are obtained more automatically, in other words, computer-based, computer-based. A computer-based information system is a mechanism consisting of people, hardware, software, data and procedures obtained both in-house and out-of-organization ways within a certain period of time, which imposes a responsibility on those who want to satisfy the need for information. This system can sometimes be a concrete object, or an abbreviation, or an event. When performing system classification, logical identification and physical description of the system are often performed. A system based on a logical definition expresses the elements necessary for a system in a broad sense, or in short terms. The physical description of the system, on the other hand, sees the same system as a whole based on how it is actually implemented. A point about the information system is also the use and nature of information, or its quality [2,9]. Successful information systems, measure the satisfaction of the users of the paddock who believed that it could be assessed with the view expressed in the following way; information users, i.e. end-users that exist in an organization with many systems analyst, information needs analysis, with a

degree and end users with the level of the participants in the system are correlated with the level of the computer. Information systems have attributed the success of the system to those who use this system or to the support of management. Ways, techniques and methods that provide optimal benefits in the development of information systems are only useful when the system is perceived effectively and the communication environment is provided. The effectiveness of the information system depends on the manager who manages it in an organization, the manager coordinates the actions of the information source from the moment it reaches its user. The effective functioning of Information Systems is to understand whether or changed completely revamp the current system and to arrive at the decision to

### **3. Conclusions**

In this study, the phenomenon of big data, application areas of big data, big data analytics and big data security dimensions were investigated. In this context, we focused on the benefits to be obtained from Big Data applications, big data analytics and Hadoop processes with his wife-on the basis Demote examined the benefits of big data, as well as the privacy of personal information that can compromise the security issues of big data and highlighted the measures to be taken regarding the safety of technical and social dimensions were evaluated. Relational database management systems such as SQL, which are currently used for structural data, are insufficient for analyzing non-structural data types. For the analysis of non-structured data, advanced analytical methods working on a distributed file system are used. Big data software architectures may be insufficient to ensure data privacy and security due to the fact that they are developed with open source code. While it is a known fact that big data has the potential to be useful to humanity in many areas, the fact that it may compromise the privacy of personal

### **References**

- 1.S.Achsas, E.H.Nfaoui, Improving Relational Aggregated Search from Big Data Sources Using Deep Learning. 2017 Intelligent Systems and
- 2.J.Archenaa, E.A.M.Anita, A Survey of Big Data Analytics in Healthcare and Government. Procedure Computer Science, Vol.50, pp.408-413, 2015.  
<https://www.semanticscholar.org/paper/A-Survey-of-Big-Data-Analytics-in-Healthcare-and-Archenaa-Anita/7d9991fd722bd63f1633ba11091c974da69352c2>
- 3.S.Asalam, Facebook by the Numbers: Stats, Demographics & Fun Facts., 2018.

bring a different system, organizations must take account of the following problems: a report that contains information appropriate for their current position rather than Administrators, more detailed time we are confronted with field reports. This is especially true when the terminology used in the report is complex, which can cause misunderstanding. The number of reports received by managers, in other words, the amount of information is excessive and time consuming. Unnecessary information is reflected in the cost to the institution. Another problem of managers is to receive information or reports that are not time-oriented. Reports that are filled with a high percentage of errors will have a negative impact on the internal customer or the external customer, which will affect customer satisfaction [7].

data also comes across as a security issue that needs to be addressed. Data that does not make sense at first can be combined with different data to decipher information that has a privacy value. At this point, it is an undeniable fact that those who have big data in their hands and those who are successful in the process of converting big data into information will achieve the ability to manage societies. While we are the people who create the data, the fact that only a few giant search engines and social media companies have the dec data in general brings to mind a new phenomenon, the “big data threat”. In the sociological dimension, first of all, the phenomenon of big data on national and international platforms should be addressed in all its aspects and legal regulations should be made to address data privacy. In addition, it should be acted upon with the awareness that data is created almost every minute with the sensor tools used, smartphones and Internet activities, and in this context, big data awareness should be brought to the society with its pros and cons.

Computer Vision (ISCV), Morocco, Fez, pp.1-6, 2017.

<https://www.omnicoreagency.com/facebook-statistics/>

4.O.G. Enlightened, pp.4-13, 2017.

5.K.Bakshi, Considerations for Big Data: Architecture and Approach. 2012 IEEE Aerospace Conference, Big Sky, MT, U.S.A., pp.1-7, 2012.

6.D.Boyd, K.Crawford, Six Provocations for Big Data. A Decade in Internet Time: Symposium on the

<https://www.researchgate.net/publication/315471275>  
[The Role of Big Data and Predictive Analytics i  
n Retailing](#)

7.E.T.Bradlow, M.Gangwar, P.Kopalle, S.Voleti.,  
The Role of Big Data and Predictive Analytics in  
Retailing. Journal of Retailing, pp.79-95, 2017.

8.S.Chandra, S.Ray, R.T.Goswami, Big Data  
Security: Survey on Frameworks and Algorithms.  
2017 IEEE 7th International Advance Computing  
Conference (IACC), Hyderabad, India, pp.48-54,  
2017.

[https://www.semanticscholar.org/paper/Big-Data-  
Security-in-Healthcare%3A-Survey-on-and-Chandra-  
Ray/d86fefa2b1f9a2c032fca670a1f3fd3b25b7711b](https://www.semanticscholar.org/paper/Big-Data-Security-in-Healthcare%3A-Survey-on-and-Chandra-Ray/d86fefa2b1f9a2c032fca670a1f3fd3b25b7711b)

9.S.Charney, Trustworthy Computing Next Microsoft  
Corporation Trustworthy Computing, pp.17-38, 2012.

10.S.Charney, RSA Conference 2012 Keynote - TwC  
for Our Computing Centric Society, pp.25-63, 2012.

11.M.Cox, D.Ellsworth, Application-Controlled  
Demand Paging for Out-of-core Visualization.  
Proceedings of the 8th Conference on  
Visualization'97, Phoenix, U.S.A., pp.235-244, 1997.

[https://www.nas.nasa.gov/assets/pdf/techreports/1997/  
/nas-97-010.pdf](https://www.nas.nasa.gov/assets/pdf/techreports/1997/nas-97-010.pdf)

12.R.G.Abaszade, S.A.Mamedova, F.H.Agayev,  
S.I.Budzulyak, O.A.Kapush, M.A.Mamedova,  
A.M.Nabiyev, V.O.Kotsyubynsky, Synthesis and  
Characterization of Graphene Oxide Flakes for  
Transparent Thin Films, Physics and Chemistry of  
Solid State, Vol.22, №.3, pp.595-601, 2021.

[DOI: 10.15330/pcss.22.3.595-601](https://doi.org/10.15330/pcss.22.3.595-601)

13.S.R.Figarova, E.M.Aliyev, R.G.Abaszade,  
R.I.Alekberov, V.R.Figarov, Negative Differential  
Resistance of Graphene Oxide/Sulphur Compound,  
Journal of Nano Research Submitted, Vol.67,  
pp.25-31, 2021.

[http://dx.doi.org/10.4028/www.scientific.net/JNanoR.  
67.25](http://dx.doi.org/10.4028/www.scientific.net/JNanoR.67.25)

14.R.G.Abaszade, O.A.Kapush, S.A.Mamedova,  
A.M.Nabiyev, S.Z.Melikova, S.I.Budzulyak,  
Gadolinium doping influence on the properties of  
carbon nanotubes, Physics and Chemistry of Solid  
State, Vol. 21, №3, pp. 404-408, 2020.

<https://doi.org/10.15330/pcss.21.3.404-408>

15.R.G.Abaszade, O.A.Kapush, A.M.Nabiyev,  
Properties of carbon nanotubes doped with  
gadolinium, Journal of Optoelectronic and  
Biomedical Materials, Vol.12, №3, pp.61-65, 2020.

[https://www.chalcogen.ro/61\\_AbaszadeRG.pdf](https://www.chalcogen.ro/61_AbaszadeRG.pdf)

16.R.G.Abaszade, Analysis of carbon nanotubes, AJP  
Fizika, Vol.26, №2, section: Az, pp.25-29, 2020.

[http://www.physics.gov.az/physart/256\\_2020\\_02\\_25  
az.pdf](http://www.physics.gov.az/physart/256_2020_02_25_az.pdf)

17.Kh.M.Popal, R.G.Abaszade, Research and  
modeling of hybrid energy systems (review),  
Ecoenergetics, №1, pp.65-69, 2022.

[http://ieeacademy.org/wp-  
content/uploads/2022/05/ECOENERGETS-  
JOURNAL-No1.-2022.pdf#page=66](http://ieeacademy.org/wp-content/uploads/2022/05/ECOENERGETS-JOURNAL-No1.-2022.pdf#page=66)

18.R.A.Namazov, R.G.Abaszade, Properties of  
graphene based solar panels (review), Ecoenergetics,  
№1, pp.3-8, 2022.

[http://ieeacademy.org/wp-  
content/uploads/2022/05/ECOENERGETS-  
JOURNAL-No1.-2022.pdf](http://ieeacademy.org/wp-content/uploads/2022/05/ECOENERGETS-JOURNAL-No1.-2022.pdf)

19.O.A.Kapush, I.O.Mazarchuk, L.I.Trishchuk,  
V.Y.Morozovska, S.D.Boruk, S.I.Budzulyak,  
D.V.Korbutyak, B.N.Kulchitsky, O.G.Kosinov,  
R.G.Abaszade, Influence of the nature of the  
dispersion medium on the optical properties of CdTe  
nanocrystals during sedimentation deposition,  
Chernivtsi University Scientific Herald, Chemistry  
(819), pp.7-11, 2019.

<https://doi.org/10.31861/chem-2019-819-01>

## **Electrical and optical properties of structures formed on the basis of thin layers of different composition CdSe<sub>1-x</sub>S<sub>x</sub>**

**E.A.Khanmamedova**

*Azerbaijan State University of Oil and Industry, Baku, Azerbaijan,  
[elmira.khanmammadova@asoiiu.edu.az](mailto:elmira.khanmammadova@asoiiu.edu.az)*

**Abstract:** Obtained from the solution by chemical precipitation dedicated to the study of the dependence of the electrical and photoelectric properties of thin films CdSe<sub>1-x</sub>S<sub>x</sub> on the composition of the layers, the regimes of precipitation and heat treatment in air. Here are the volt-ampere, volt-farad, lux-ampere characteristics of CdSe<sub>1-x</sub>S<sub>x</sub> thin films of different compositions obtained in separate precipitation and heat treatment regimes in air, as well as their spectral distribution of photoconductivity and photocurrent kinetics at temperature, light intensity and wavelength. has been.

**Keyword:** Photoelectric, Electrochemical precipitation methods, Solar energy converters, Hexagonal structure, Nanostructure.

### **1.Introduction**

Although a lot of research work has been done on the methods of obtaining thin layers of solid solutions of AIBVI compounds, electrical and photoelectric properties of structures based on them and Cd<sub>1-x</sub>Zn<sub>x</sub>S thin layers, the solution of problems in the dissertation, scientific innovations and practical significance of the work to the extent not reflected. Therefore, in the presented dissertation, a complex of scientific researches was carried out in order to reveal the main features of recombination processes and current-carrying mechanisms in ZnS-based nanostructured layers obtained from solution by chemical and electrochemical precipitation methods and structures based on them [1-3]. In the papers R.G.Abaszade and others, grapheme-based samples are used to obtain greater energy in modern solar panels and hybrid systems [4-12].

### **2. Experimental detail**

In general, although there is a lot of work in the scientific literature on obtaining thin layers of binary compounds, research is still ongoing on the existing problems[1]. There is not much scientific work to obtain three- and four-component compounds. In the study, thin layers of Zn<sub>1-x</sub>Cd<sub>x</sub>Se were precipitated on steel foil from an aqueous solution of pH = 0.1M acid

The ZnS<sub>1-x</sub>Sex system obtained by electrochemical precipitation of aqueous solution shows the optical properties of the spectra of thin layers of solid solutions in the visible and near-infrared region (360-1100 nm) and the environment in which the thermal treatment is carried out (air, oxygen, argon). has been. During the research, thin layers with a thickness of 1-0.2 μm were obtained on quartz (3 mm) / SnO<sub>2</sub> (0.8 μm) substrates. It was found that after 7-8 minutes of heat treatment in an argon environment at a temperature of 3500C, the optical emission coefficient of thin layers in the range of 600-1000 nm wavelength of the spectrum is 45-87%, which allows them to be used in solar energy converters. On the basis of optical studies, the width of the forbidden strip of thin layers was determined.

consisting of 0.2M ZnSO<sub>4</sub>, 1.2mM H<sub>2</sub>SeO<sub>3</sub> and various concentrations of CdSO<sub>4</sub> salts. Sedimentation took place at a temperature of 65-700C by the following reaction:

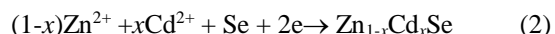
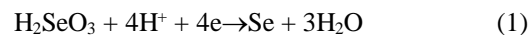

developed a technology for the deposition of thin layers of  $Zn_{1-x}Cd_xSe$  from an aqueous solution of selenosulfate on titanium bases. It was found that the reduction of Cd leads to the formation of CdSe compounds, and the reduction of  $SeSO_3^{2-}$  leads to the formation of  $Se_2^{2-}$  ions, which in turn react with metal ions to form metal selenides [1,2]. Using cyclic photovoltometry (illumination), the authors found that the formation of CdSe occurs at values of cathode voltage -1.1V. In general, the electrochemical reaction can be described as follows:

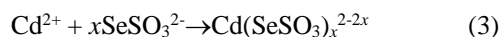

The Cd-selenosulfate complex then directly causes either CdSe or Cd:

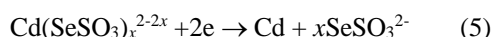

Cd then reacts to form CdSe:



It was found that the cubic phase predominates in this potential where CdSe is formed, and the hexagonal modification predominates as the cathode potential increases to -1.4 V. After direct precipitation, the amorphous thin layers were transformed into a polycrystalline structure after heat treatment at 30 ° C for 30 minutes.

The second reduction peak at -1.25 V in cyclic volt-ampere characteristic;

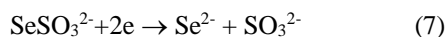

indicates the formation of  $Se_2^{2-}$  ions according to the reaction. It is also the cause of CdSe during the reaction:

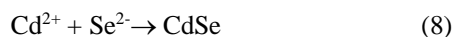

At -1.35 V of the cathode potential,  $Zn^{2+}$  ions form complexes with  $SeSO_3^{2-}$  ions, which leads to the formation of  $ZnSe$ :

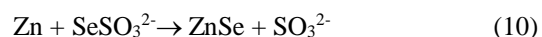
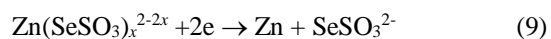

It was found that in the initial moments Zn reacts very weakly with  $SeSO_3^{2-}$  ions, only at relatively high values of the cathode potential the following reactions form

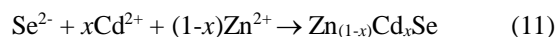

In the scientific literature, there are studies on the extraction of thin layers of solid solutions of three-component compounds of the type  $CdS_xSe_{1-x}$  and  $Zn_{1-x}Cd_xS$  from the aqueous solution. Thus, in the production of thin layers of CdS 55 mM CdCl<sub>2</sub> and saturated sulfur (190 mM); In the production of thin layers of  $CdS_xSe_{1-x}$  55 mM CdCl<sub>2</sub>, (100-400 mM), saturated selenium and (50-190 mM) saturated sulfur; Finally, in the production of thin layers of  $Zn_{1-x}Cd_xS$ , salts of CdCl<sub>2</sub> and ZnCl<sub>2</sub> at a concentration of n ( $CdCl_2 + ZnCl_2$ ) = 55 mM were used, and thin layers of different compositions were obtained by changing the Zn/Cd ratio in the solution by 1/10. Sedimentation was carried out at a temperature of 1200C and a hexagonal structure was observed in the obtained thin layers with the c axis of crystallization perpendicular to the base. The researchers also found that the thin layers had a straight band and that their dark resistance was higher than that of CdS.

In the scientific literature, mainly aqueous solutions are used in the electrochemical precipitation of thin layers of  $Zn_xCd_{1-x}Te$ . The most commonly used methods are described in more detail in the study.

In contrast, thin layers of  $Zn_xCd_{1-x}Te$  of various compositions were obtained directly from the aqueous solution of CdCl<sub>2</sub> + ZnCl<sub>2</sub>. TeO<sub>2</sub> was used as a source of Te ions by adding Te powder to an acid medium (in this case, the acidity of the solution was changed by adding HCl in the range of pH = 1.5-2.5). In the work, from a three-electrode system - SnO<sub>2</sub> as a cathode, graphite rods were applied as an anode and precipitation was carried out at room temperature. The obtained thin layers were thermally treated in vacuum at 3000C. As a result, the thin layers exhibited high crystallographic and optical properties.



### 3. Conclusions

By controlling the electrical, optical and photoelectric parameters, mechanical properties (elasticity), surface morphology (micro- or nano-textured), as well as the degree of crystallization of the cathode potential in the process of electrochemical precipitation and the type of salts in the solution (sulfate and or chloride-containing) can be administered by varying the concentration. The surface morphology and crystallization orientation of the thin layers obtained by electrochemical precipitation depend on the

structure of the substrate and the technological regime. Although there is a great deal of work on the electrochemical precipitation of thin layers of two- and three-component solid solutions based on AIBVI compounds, there is no information on the production and study of four-component thin layers. Crystallographic, morphological, electrical, photoelectric and optical parameters of thin layers can be controlled by thermal operation in different environments (vacuum, nitrogen, argon, etc.) and modes.

### References

1. M.A. Jafarov, E.F. Nasirov, E.A. Khanmamedova, Preparation of nanosized  $A^2B^6$  Compound Multilayer Structures for Solar Cell, *Universal Journal of Physics and Application* 1(2): pp.125-129, 2013  
<https://www.hrpub.org/download/201309/ujpa.2013.010212.pdf>
2. М.А. Джафаров, Э.Ф. Насиров, С.А. Джахангирова, Е.А. Ханмамедова, Фотохимическая реакция в наноразмерных пленках твердых растворов  $A^2B^6$ , осажденных из раствора, Российская Федерация, г. Воронеж, Конденсированные среды и межфазные границы, том 15, № 3, 2013.  
[http://www.kcmf.vsu.ru/resources/t\\_15\\_3\\_2013\\_007.pdf](http://www.kcmf.vsu.ru/resources/t_15_3_2013_007.pdf)
3. H.M. Mamedov, M. Muradov, M. Jafarov, Z. Konya, A. Kukovecz, K. Kordas, S.I. Shah, V.J. Mamedova, Kh.M. Ahmedova, V.U. Mamedov, E.A. Khanmamedova, Photo- and gas- sensitivity of heterojunctions c-Si/porous-Si/CdS, *Journal of Low Dimensional Systems*, Vol.1 (1), 2017.  
[https://www.researchgate.net/publication/323280578\\_Photo\\_and\\_gas\\_sensitivity\\_of\\_heterojunctions\\_c-Siporous-SiCdS](https://www.researchgate.net/publication/323280578_Photo_and_gas_sensitivity_of_heterojunctions_c-Siporous-SiCdS)
4. O.A. Kapush, I.O. Mazarchuk, L.I. Trishchuk, V.Y. Morozovska, S.D. Boruk, S.I. Budzulyak, D.V. Korbutyak, B.N. Kulchitsky, O.G. Kosinov, R.G. Abaszade, Influence of the nature of the dispersion medium on the optical properties of CdTe nanocrystals during sedimentation deposition, *Chernivtsi University Scientific Herald, Chemistry* (819), pp.7-11, 2019.  
<https://doi.org/10.31861/chem-2019-819-01>
5. S.R. Figarova, E.M. Aliyev, R.G. Abaszade, R.I. Alekberov, V.R. Figarov, Negative Differential Resistance of Graphene Oxide/Sulphur Compound, *Journal of Nano Research Submitted*, Vol.67, pp.25-31, 2021.  
<http://dx.doi.org/10.4028/www.scientific.net/JNanoR.67.25>
6. R.G. Abaszade, O.A. Kapush, S.A. Mamedova, A.M. Nabiyev, S.Z. Melikova, S.I. Budzulyak, Gadolinium doping influence on the properties of carbon nanotubes, *Physics and Chemistry of Solid State*, Vol.21, №3, pp. 404-408, 2020.  
<https://doi.org/10.15330/pcss.21.3.404-408>
7. R.G. Abaszade, O.A. Kapush, A.M. Nabiyev, Properties of carbon nanotubes doped with gadolinium, *Journal of Optoelectronic and Biomedical Materials*, Vol.12, №3, pp.61-65, 2020.  
[https://www.chalcogen.ro/61\\_AbaszadeRG.pdf](https://www.chalcogen.ro/61_AbaszadeRG.pdf)
8. R.A. Namazov, R.G. Abaszade, Properties of graphene based solar panels (review), *Ecoenergetics*, №1, pp.3-8, 2022.  
<http://ieeacademy.org/wp-content/uploads/2022/05/ECOENERGETS-JOURNAL-No1.-2022.pdf>
9. Kh.M. Popal, R.G. Abaszade, Research and modeling of hybrid energy systems (review), *Ecoenergetics*, №1, pp.65-69, 2022.  
<http://ieeacademy.org/wp-content/uploads/2022/05/ECOENERGETS-JOURNAL-No1.-2022.pdf#page=66>
10. R.G. Abaszade, S.A. Mamedova, F.H. Agayev, S.I. Budzulyak, O.A. Kapush, M.A. Mamedova, A.M. Nabiyev, V.O. Kotsyubynsky, Synthesis and Characterization of Graphene Oxide Flakes for Transparent Thin Films, *Physics and Chemistry of Solid State*, Vol.22, №.3, pp.595-601, 2021.  
[DOI: 10.15330/pcss.22.3.595-601](https://doi.org/10.15330/pcss.22.3.595-601)
11. R.G. Abaszade, X-ray diffraction analysis of carbon nanotubes doped by 10% gadolinium, *AJP Fizika*, Vol.26, №1, section: Az, pp.36-38, 2020.  
[http://www.physics.gov.az/physart/246\\_2020\\_01\\_36\\_az.pdf](http://www.physics.gov.az/physart/246_2020_01_36_az.pdf)
12. R.G. Abaszade, S.A. Mamedova, S.T. Azizov, O.A. Aliyev, E.M. Aliyev, A.M. Nabiyev, Synthesis and analysis of few-layered graphene oxide, *AJP Fizika*, Vol.25, №2, section: Az, pp.56-49, 2019.  
[http://physics.gov.az/Dom/2019/AJP\\_Fizika\\_02\\_2019\\_az.pdf](http://physics.gov.az/Dom/2019/AJP_Fizika_02_2019_az.pdf)



ECO

ENERGETIKA  
ENERGETICS

